



Technical Bulletin

Flow/Pressure Test Kit 6801582

This sheet describes how to install and use Flow/Pressure Test Kit 6801582 (includes Flow Meter Kit 6043182 and Pressure Gauge Kit 671212). These kits are used to determine if relief valve cartridges need adjustment or for troubleshooting an attachment.

Flow Meter Kit

To check flow volume, install flow meter between the truck and attachment valve or cylinder, as shown.

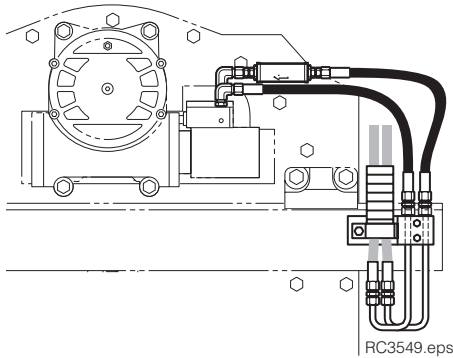

To Attachment Valve

Example: Rotator, Push/Pull

RC3549.eps

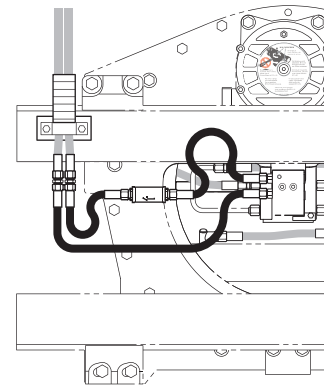

To Manifold

Example: Roll Clamp

CL4484.eps

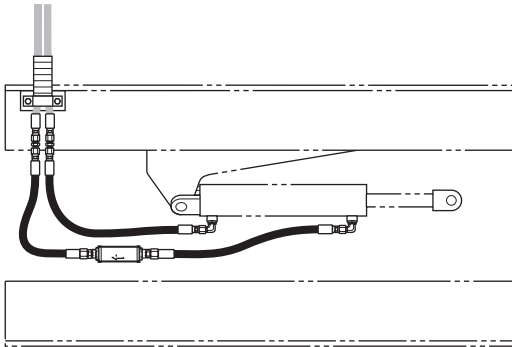

To Cylinder Port

Example: Sideshifter

FP1394.eps

NOTE: This information should not be interpreted as the basis for warranty claims unless so designated.

cascade[®]
corporation

For Technical Support . . .

Call: 1-800-CASCADE (227-2233)

OR

Write: Cascade Corporation, PO Box 20187, Portland, OR 97294-0187

To Order Parts . . .

Call: 1-888-CASCADE (227-2233)

OR

Write: Cascade Corporation, 2501 Sheridan Ave., Springfield, OH 45505

Pressure Gauge Kit

To check pressure, install gauge into a gauge port on the attachment valve, cylinder gauge port or tee gauge into a supply line to an attachment function port (example: sideshift cylinder, revolving connection, etc.).

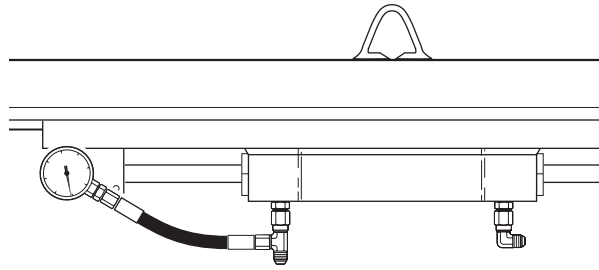

FP1396.eps

Tee at Cylinder Port

Example: Sideshifter

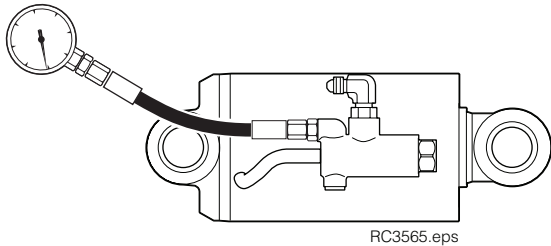

RC3565.eps

Cylinder Gauge Port

Example: Roll Clamp

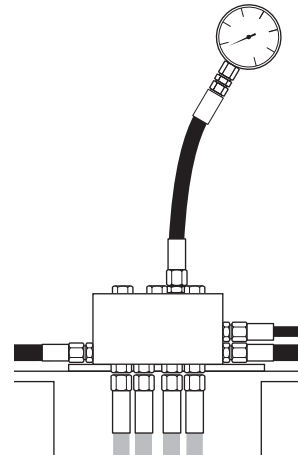

CL4485.eps

Attachment Valve Gauge Port

Example: Rotator, Clamp

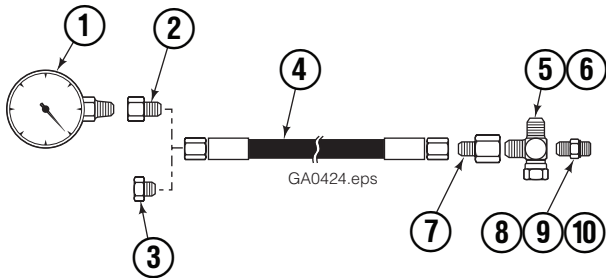

GA0424.eps

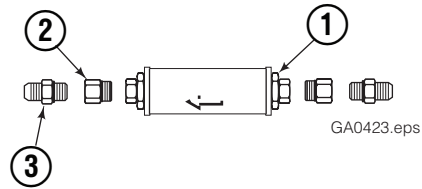

GA0423.eps

| REF | QTY | PART NO. | DESCRIPTION |
|-----|-----|----------|----------------------|
| | | 671212 | Gauge Kit |
| 1 | 1 | 6006017 | Gauge with Guard |
| 2 | 1 | 2331 | Fitting, 4-6 |
| 3 | 1 | 2659 | Plug |
| 4 | 1 | 671213 | Hose |
| 5 | 1 | 611329 | Fitting, 6-6 |
| 6 | 1 | 611330 | Fitting, 8-8 |
| 7 | 1 | 2671 | Reducer Fitting, 8-6 |
| | 1 | 2618 | Nut |
| 8 | 1 | 672026 | Fitting, 6-4 |
| 9 | 1 | 604511 | Fitting, 6-6 |
| 10 | 1 | 611288 | Fitting, 6-8 |

| REF | QTY | PART NO. | DESCRIPTION |
|-----|-----|----------|----------------|
| | | 6043182 | Flow Meter Kit |
| 1 | 1 | 6044027 | Flow Meter |
| 2 | 2 | 201268 | Fitting, 16-8 |
| 3 | 2 | 601377 | Fitting, 8 |