



Technical Bulletin

D-Series Carton Clamp Arm Bar Bearing Shim Service Kit 675326

This sheet describes the installation of Shim Service Kit 675326. The shims increase the arm bearing life by maximizing the surface area that the arm bar contacts. Arm sag is decreased and more accurate camber adjustment results by decreasing the amount of looseness between the arm bars.

- 1 Extend the arms. Lower the attachment to position the contact pads 1/2" above the floor. Remove the cotter pin, locking cap and nut retaining the cylinder rods to the arm lugs.
- 2 Attach a suitable overhead hoist and chain to the arm. The chain must be kept away from the arm bearing surface.
- 3 Retract the cylinder rods until they come out of engagement with the arm lugs.
- 4 Pull the arm assemblies out of the aluminum frames.
- 5 Remove the bearing spacers located between the upper and lower bearing strips in each arm bar opening.
- 6 Pry the bearing strips out of the frame with a screwdriver and slide outward.

CAUTION: Do not gouge aluminum frame surfaces.

NOTE: To ease removal of the first bearing strip from the frame, push the innermost boss out of its hole.

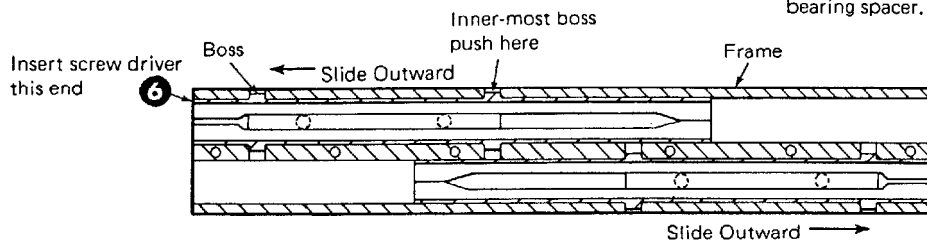
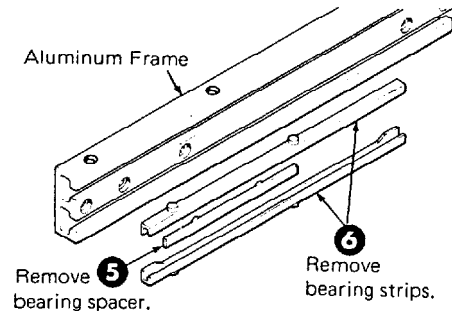
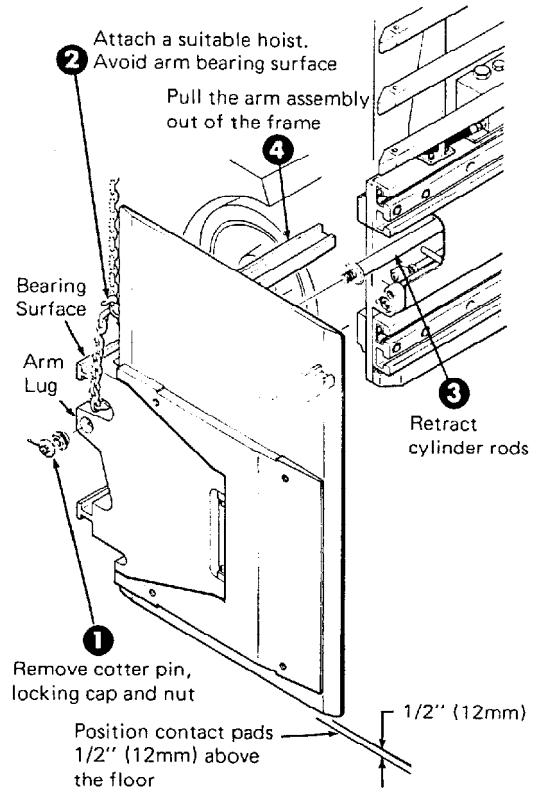

Part Number 675327 R-1

cascade®

For Technical Assistance and to Order Parts . . .

Call: 1-800-CASCADE or 503-669-6300

FAX: 503-669-6338

Write: Cascade Corporation, PO Box 20187, Portland, OR 97220

- 7 Use dial calipers to measure dimension **A** of both ends of arm bar openings in upper and lower aluminum frames.
- 8 Place an upper and lower bearing strip on each arm bar. Measure dimension **B**.
- 9 Determine the shim thickness required to leave .015 in. clearance between each set of bushing strips and each arm bar opening. Use the following formula:

$$(\text{Dim. A} - .015 \text{ in.}) - \text{Dim. B} = \text{Shim thickness required}$$

Example: $A = 2.165 \text{ in.}$, $B = 2.085 \text{ in.}$

$$(2.165 \text{ in.} - .015 \text{ in.}) - 2.085 \text{ in.} = .065 \text{ in.}$$

1 Pink Shim = .015 in.

1 Yellow Shim = .020 in.

Use 3 yellow shims = .060 in.

- 10 Decrease the width of the bearing spacer to the dimension shown to provide room to install the bearing strips.
- 11 Tape the required shims for each arm bar opening to the lower bearing strip only. Install the bearing strips and bearing spacers.
- 12 After reinstalling the arms in the frames, check for excess tightness of the arm bars while sliding in the frames.
- 13 For reassembly, reverse above procedures except for the following special instructions for cylinder anchors:

- Lubricate the cylinder rod threads, nut threads and spherical portion of the nut with STP.
- Install the washer on the cylinder rod end with the beveled side facing the lug.
- Engage the rod end into the lug.
- Tighten the rod end nut to a torque of 150-175 ft.-lbs. Prevent the rod turning by using a wrench on the hex washer.

NOTE: The rod end nut is being tightened against the hex washer. The nut will not be tight against the arm lug. This looseness allows for frame deflection during clamping.

- Install the locking cap and cotter pin.
- Lubricate the bearing portion of the arm bars with a thin film of chassis grease.

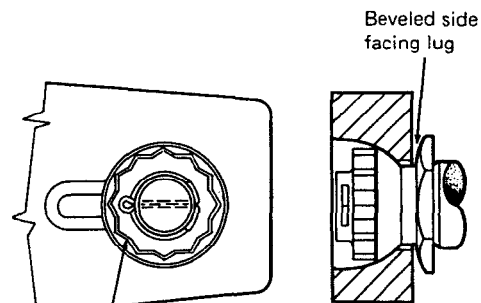
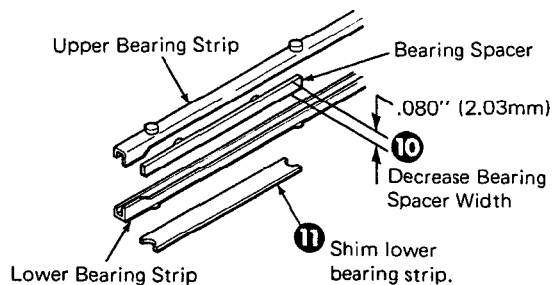
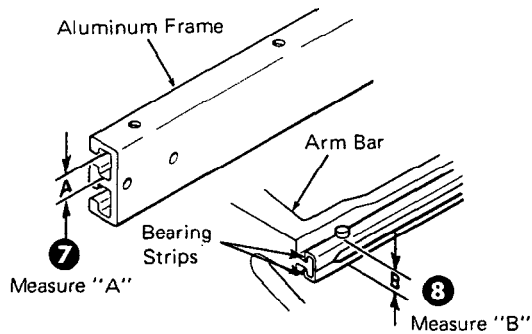

Tighten rod end nut to a torque of 150–175 ft.-lbs. (200–235 N·m) (lubed).