



Installation Service and Parts Manual

6-N-1 Cable-Hose Reel

Serial Numbers 677834 through 677845

Manual Number 680018

cascade[®]

Cascade is a Registered Trademark of Cascade Corporation

CONTENTS

INTRODUCTION	1
PRIOR TO INSTALLATION	1
INSTALLATION	2
SERVICE	
SEAL AND SPRING ASSEMBLY REPLACEMENT	5
INNER CABLE REPLACEMENT	8
OUTER CABLE-HOSE REPLACEMENT	10
TROUBLESHOOTING GUIDE	12
ELECTRICAL TROUBLESHOOTING GUIDE	13
CABLE-HOSE LENGTH CALCULATIONS	14
PARTS LISTS	15-19

INTRODUCTION

This booklet contains the complete PARTS, INSTALLATION, and SERVICE information for the 6-N-1 Cable-Hose Reels. The manual also includes TROUBLESHOOTING GUIDES located on page 12 and 13. If you have additional questions, call the nearest Cascade Service Department listed on the back cover.

To order replacement parts contact the Cascade Central Parts Depot at:

Cascade Corporation
P.O. Box 360
Springfield, Ohio 45505
(513) 322-1199
TELEX: 279563
FAX: 1-513-325-9270

PRIOR TO INSTALLATION

To make the truck and attachment cables compatible with the reel cable connectors, attach the pin and socket connectors (included with the reel) to the truck and attachment cable ends according to the following procedures.

1. Crimp the pin connectors to the truck cable end with VACO Part No. 1900 or Waldom Part No. HT 1919, one of which is included in Tool Kit Part No. 676314 (six pin connectors are supplied with the reel). Use one pin connector per function plus one additional pin connector as a ground.

2. Install the pin connector housing.

CAUTION: To maintain a uniform electrical circuit and to prevent electrical shocks, establish a connection pattern to be used at all connector locations.

3. Crimp the socket connectors to the attachment cable end with VACO Part No. 1900 or Waldom Part No. HT 1919, one of which is included in Tool Kit Part No. 676314 (six socket connectors are supplied with the reel). Use only one socket connector per function plus one additional socket connector as a ground.

4. Install the socket connector housing using the established connection pattern.

NOTE: The following information is supplied for your convenience in establishing a connection pattern. The wire harness installed in the reel is connected to the pins or sockets in the following pattern:

Pin/Socket No. 1 – Purple	4 – Yellow or Pink
2 – Green	5 – White
3 – Black or Blue	6 – Red

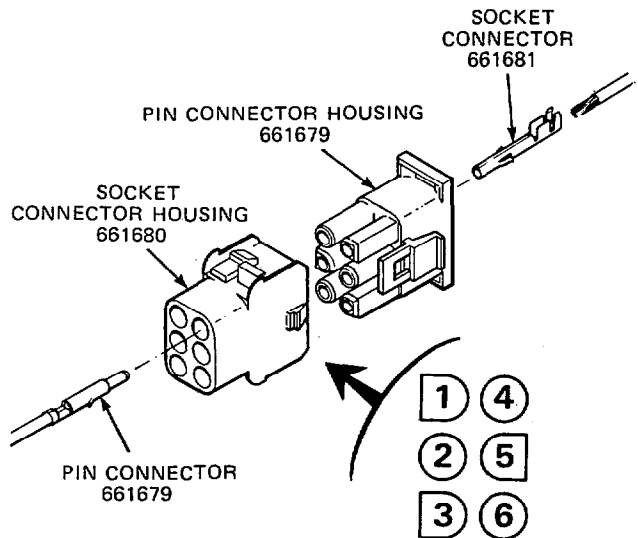

INSTALLATION

IMPORTANT: Do not allow the reel to rotate on its shaft at this time. Doing so will prewind the spring. The wire attaching the Caution Tag to the reel must stay in place until the reel is to be prewound and cable-hose connected to the junction block.

1. Determine a location for the mounting pad keeping in mind the following points:
 - a. **Locate the mounting pad** on the mast channel or truck cowling. See Figure 1. **The reel flanges must not interfere with:**
 - The truck overhead guard when the mast is tilted all the way back (if the reel is mounted on the mast).
 - The truck carriage as it moves past the reel (if the reel is mounted on the mast).
 - The mast channel members when the mast is tilted all the way back (if the reel is mounted on the truck cowling).

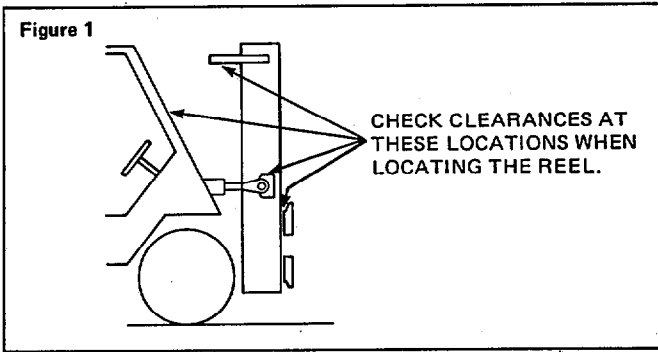

- b. The inner reel flange should be no more than 1/4 in. from the side of the mast and should be placed behind the mast channel rather than along side it. See Figure 1A.
- c. The reel should not extend beyond the widest part of the truck to prevent possible damage to the reel during truck operation.

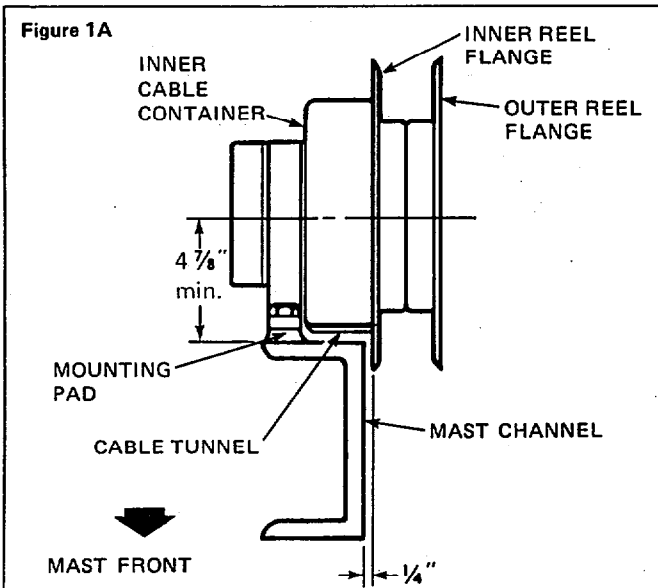

- d. If you are not using the Cascade Mounting Pad, make sure that your pad has a thickness of at least 5/8 inch.
2. Weld the mounting pad in place using a 3/16 in. fillet weld (use E60XX rod with no preheat or postheat) along the vertical sides of the mounting pad only. See Figure 2. Cover the mast hoist chains to shield from weld splatter.
3. Attach the reel mounting brackets to the mounting pad using the mounting capscrews and lockwashers supplied with the reel. See Figure 2.

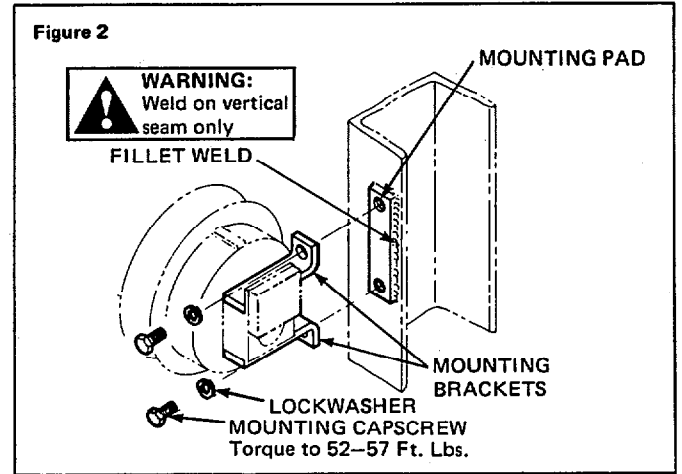

4. Remove the fixed cover from the mounting block on the backside of the reel. See Figure 3.
5. Join the cable connector of the inner cable to the cable connector of the truck cable using the established connection pattern for all cable ends. See page 1.
6. Remove the clamp from the mounting block and fit it around the truck cable. Reinstall the clamp on the reel mounting block. See Figure 3.

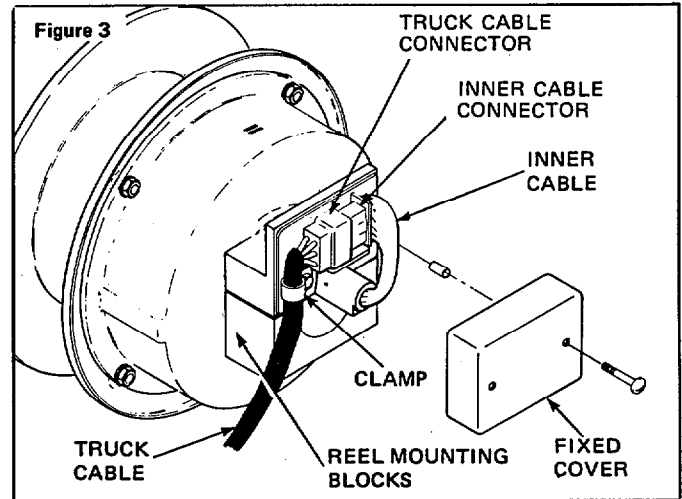

7. Install the fixed cover on the mounting block. Tighten the screws.

CAUTION: Overtightening the screws will damage the fixed cover.
8. Connect the truck valve hoses to the reel shaft.

9. Raise the carriage to a position approximately even with the top of the reel. The junction block should be positioned so that it is centered between the reel flanges. See Figure 4. Using the junction block as a guide, mark the location of the junction block mounting holes on the back side of the carriage. Make sure the junction block is positioned vertically.
10. Lower the truck carriage to the floor.
11. Drill and tap both holes at the location marked on the carriage. Figure 4 shows the diameter and drilling information for the two holes. The thread depth should be drilled a minimum of 1/2 inch.

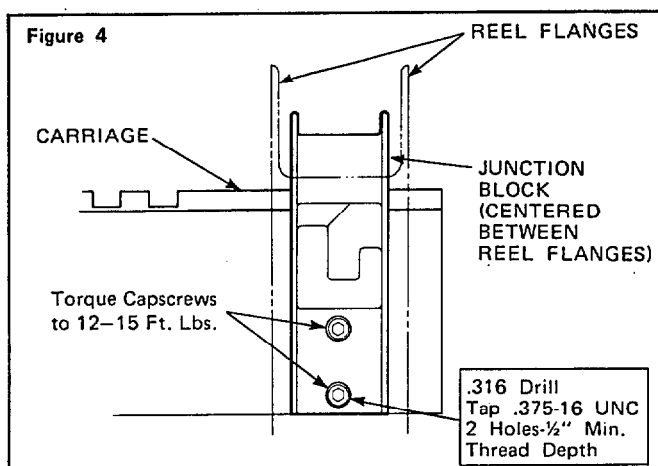

12. Install the junction block on the carriage using the capscrews and lockwashers supplied with the junction block.
13. Determine the cable-hose length required as shown in the Cable-Hose Length Calculations, see page 14.
NOTE: This step may be by-passed if you have been supplied with a pre-assembled cable-hose of the correct length.
14. Connect the hoses to the reel hub fittings. See Figure 5. Put the end of the cable inside of the outer flange area.

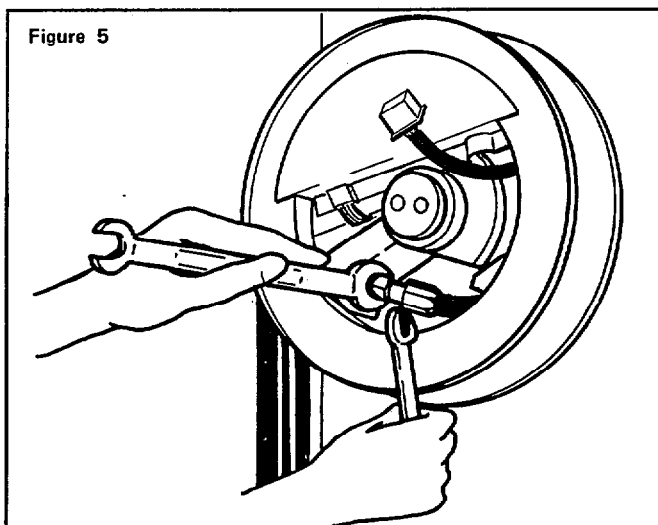

15. To install the outer cable-hose on the reel, remove the two hub nuts securing the rotating cover to the outer flange. Remove the rotating cover. See Figure 6.
16. Join the outer cable connector to the inner cable connector using the established connection pattern. See Figure 6.

17. Fit the cable clamps to the outer cable and secure them as shown in Figure 6.
18. Install the rotating cover and hub nuts. The inner cable must be laying flat in the flange depression and not pinched. Tighten the hub nuts.

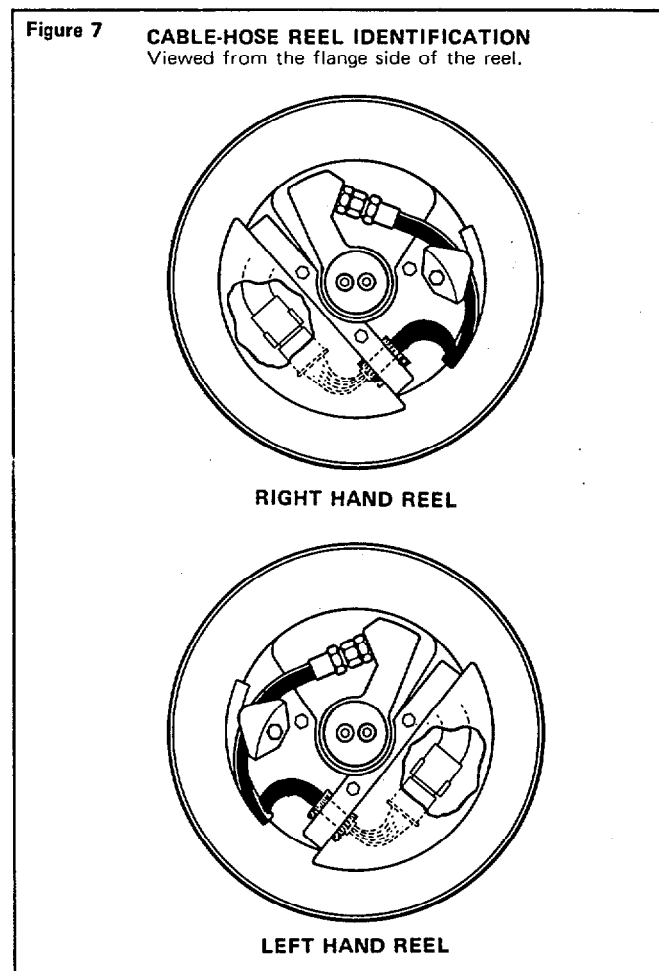
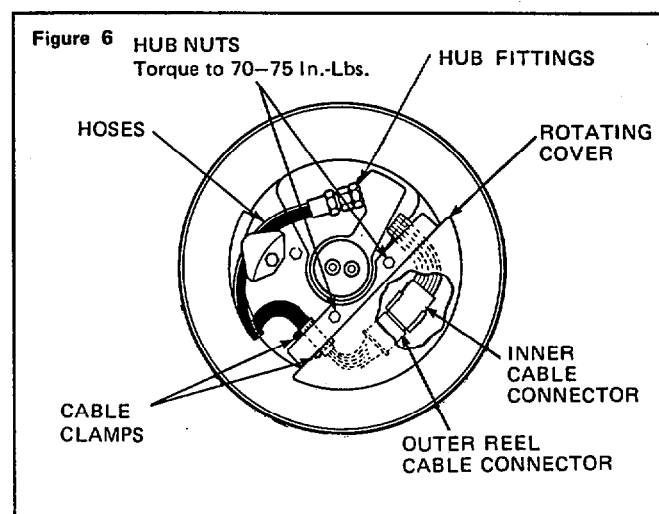

19. Wind the outer cable-hose completely onto the reel in the direction indicated (viewed from the flange side):
Right Hand Reel: Wind cable-hose clockwise.
Left Hand Reel: Wind cable-hose counterclockwise.
A Right or Left hand reel is determined as viewed from the flange side of the reel. See Figure 7.

20. Remove the caution tag and wire.
21. Rewind the reel spring by grasping the end of the outer cable-hose and turning the reel a minimum of 3 turns in the direction indicated (viewed from the flange side):

Right Hand Reel: Wind reel clockwise.

Left Hand Reel: Wind reel counterclockwise.

CAUTION: Rotation in a wrong direction will damage the inner cable and reel spring.

If more tension is required, the reel can be prewound additional turns. The maximum turn capacities are:

Standard Reel: 16 total turns.

Cold Storage Reel: 12 total turns.

Total turns = Prewind turns + Working turns.

CAUTION: Exceeding turn capacity of the reel will damage the inner cable and reel spring.

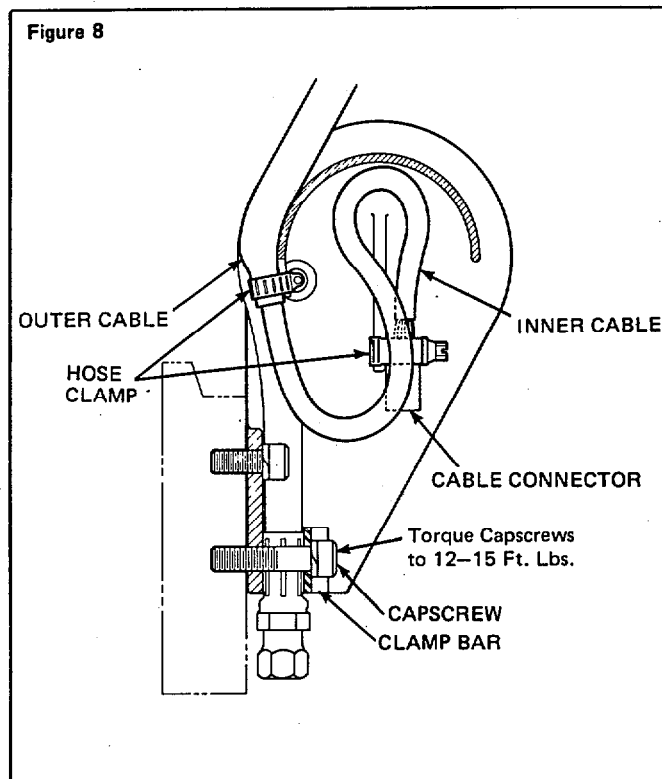

22. With the reel prewound, pull the hose ends down to the junction block. Fasten the hoses with the clamp bar and capscrew. See Figure 8.



WARNING: Do not let the reel unwind when connecting the cable-hose to the junction block.

23. Connect the cable from the cable-hose to the junction block. Clamp the outer cable to the projection between the hoses with a hose clamp. See Figure 8. Position the hose clamp so it can be tightened through the hole in the side of the junction block. Route the inner cable through the junction block as shown. Fasten the male cable connector to the large projection with a hose clamp. Form the hose clamp around the connector. Do not overtighten the clamp. The female cable connector must fit in the male connector. Joint the connectors.
24. Connect the attachment hoses to the junction block. Be sure the hoses and their functions do not become interchanged. See Figure 9.
25. Operate the carriage up and down a few times to make sure the cable-hose tracks smoothly and no interference exists.

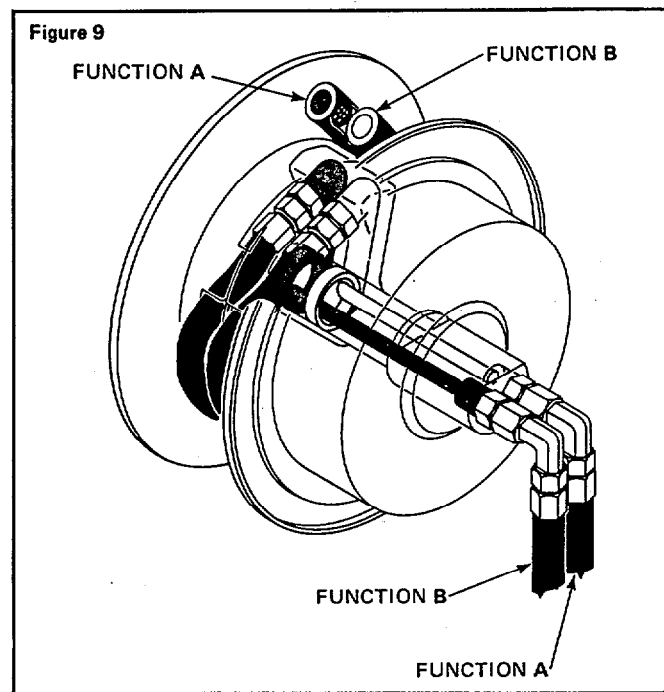

SEAL AND SPRING ASSEMBLY REPLACEMENT

DISCONNECTING THE REEL

1. Disconnect the cable connectors at the junction block.



WARNING: Hold hoses firmly while disconnecting cable-hose from the junction block. Allow the reel spring to unwind slowly while maintaining tension on the loose cable end. See Figure 10.

2. Remove the cable-hose from the junction block.

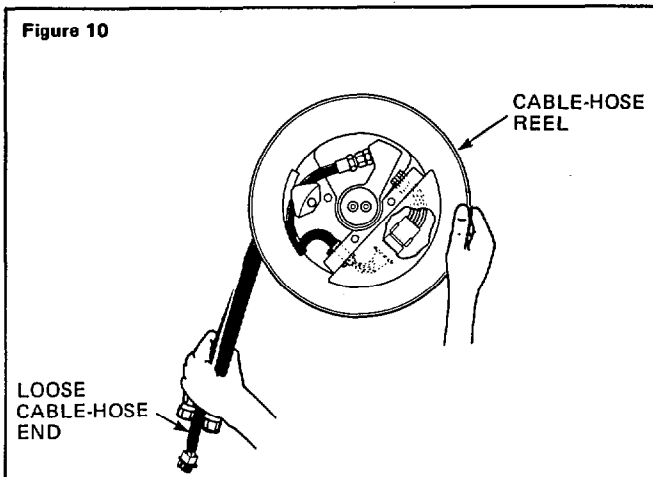

3. Remove fixed cover from the mounting block. Disconnect the inner cable connector from the truck cable connector. See Figure 3.
4. Disconnect the truck valve hoses from the shaft.
5. Remove the capscrews and lockwashers fastening the reel to the mounting pad. Remove the reel from the mast.

REEL DISASSEMBLY

1. Remove the nuts from the hub studs and lift off the rotating cover. See Figure 11.
2. Disconnect the reel outer cable connector from the inner cable connector. See Figure 11.
3. Disconnect the hoses from the reel hub fittings.
4. Remove the four nuts and washers attaching the inner cable housing to the inner reel flange. See Figure 11.
5. Scribe a mark on the inner cable housing and the inner reel flange to aid in alignment during reassembly. See Figure 11.
6. **RIGHT HAND REEL** (See Figure 7.)
 - a. Pull both flanges (with outer cable) off the hub studs. Rotate the flanges slightly to free the inner cable connector. See Figure 11.
 - b. Remove the hub outer snap ring.
 - c. Pull the hub off the shaft.
 - d. Leave the stud bracket and spacer on the hub.

NOTE: Since the O-rings in the hub produce friction, it may be necessary to tap gently on the end of the shaft with a rubber mallet or hammer handle while pulling on the hub.

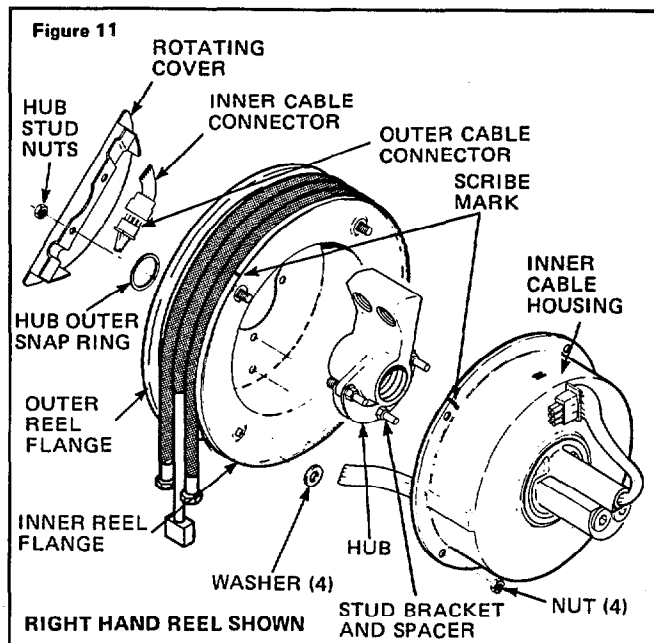

LEFT HAND REEL (See Figure 7.)

- a. Remove the hub outer snap ring. See Figure 11.
 - b. Pull the hub off the shaft.
 - c. Remove both flanges (with outer cable) and the stud bracket.
7. Remove the seals from the hub. Avoid scratching grooves. Clean the hub and shaft with solvent.
 - The sealing surface on the shaft is nickel plated. If minor surface imperfections are noted, use emery cloth (320 Grit) to lightly smooth up. If sharp edges or grooves are found, shaft replacement is necessary. See Figure 12.
 - Hub grooves must be free of sharp nicks or projections to prevent cutting of the outside diameter of the O-ring during installation. See Figure 12.

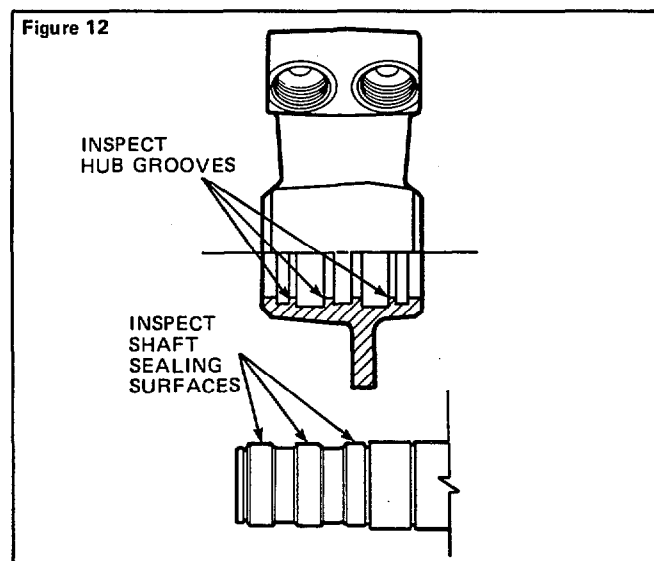

SPRING ASSEMBLY REPLACEMENT

NOTE: If the spring assembly does not require replacement, delete this step and proceed to **Reel Assembly**.

1. Disengage the spring from the spring retainer on the shaft. See Figure 13.

CAUTION: Do not allow the inner cable housing to rotate independently of its hub. Damage to the inner cable will occur if they are rotated. Use tape or wire to hold both from rotating. See Figure 13. **If either has been rotated** refer to the **Inner Cable Housing Timing** instructions on page 9.

2. Hold the reel assembly by the outside of the inner cable housing over a work bench with the shaft downward. Tap the shaft end on the bench. Slide the spring assembly out of the inner cable housing and off the shaft.
3. If the spring retainer has been damaged, remove the spring retainer snap ring and install a new spring retainer. See Figure 13.
4. Slide the new spring assembly onto the shaft. Secure the spring end on the spring retainer by turning the spring on the shaft. Make sure the notch in the spring assembly is aligned with the inner cable. See Figure 13.

REEL REASSEMBLY

1. Lubricate the shaft, seals and bore of the hub with hydraulic oil.
2. Install the back-up rings into the hub grooves. Place a portion of ring in the groove, then bend as required to install. See Figure 14. Install the O-ring seals.

NOTE: When servicing the inner cable housing or installing a new shaft seal kit, the cable harness (inside the inner cable housing) should be lubricated with TRI-FLON spray lube, Cascade Part No. 669779. See **Inner Cable Replacement** for assembly instructions on page 8.

Figure 14

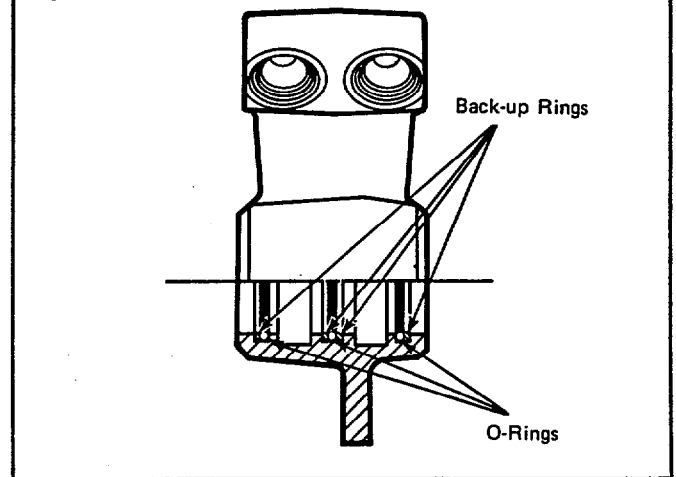

3. RIGHT HAND REEL (See Figure 7.)

- a. Rotate the hub slowly as you slide it onto the shaft.
- b. Install the hub outer snap ring. See Figure 11.
- c. Place the reel flanges onto the hub, aligning the scribe mark on the inner cable container to the scribe mark on the inner reel flange.

LEFT HAND REEL (See Figure 7.)

- a. With the stud bracket and spacer on the inside of the reel flanges, slide the hub and reel flanges as one unit onto the shaft.
- b. Align the scribe mark on the inner cable container to the scribe mark on the reel flanges.
- c. Install the hub outer snap ring. See Figure 11.

Figure 13

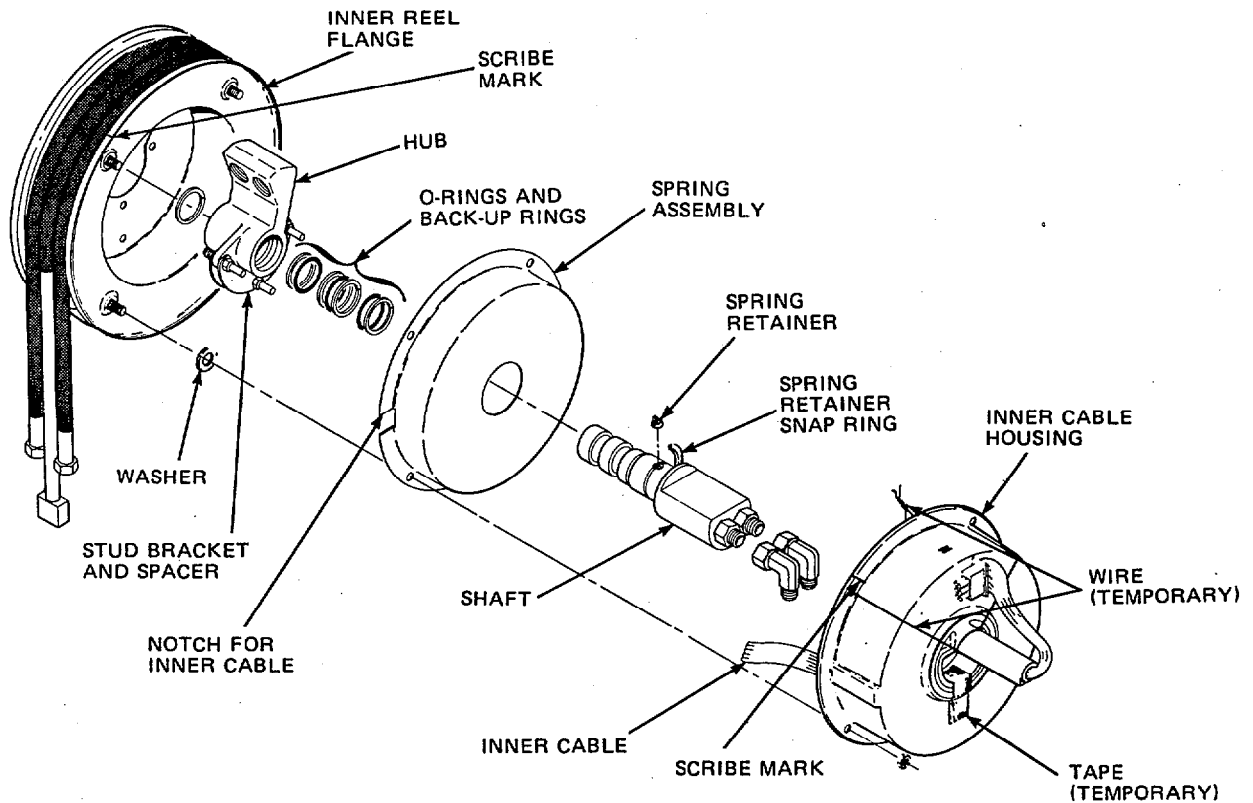

RIGHT HAND REEL SHOWN

4. Install the capscrews, lockwashers and nuts to fasten the inner reel flange to the inner cable housing. See Figure 13.
5. Reconnect inner and outer cable connectors. See Figure 15.
6. Connect the hoses to the reel hub fittings.
7. Install the rotating cover and hub nuts. The inner cable must be laying flat in the flange depression and not pinched. Tighten the nuts to a torque of 70–75 in.-lbs.
8. Remount the reel onto the truck.
 - a. Reconnect the inner cable connector to the truck cable at the mounting block. See Figure 3.
 - b. Attach the clamp to the truck cable and secure the clamp to the mounting block. See Figure 3.
 - c. Install the fixed cover.

CAUTION: Overtightening the capscrews will damage the fixed cover.
9. Connect the truck valve hoses to the shaft.

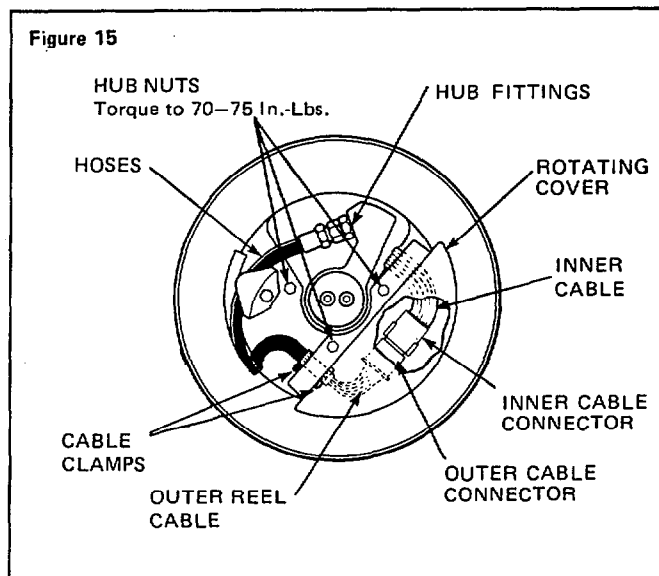

10. Make sure cable-hose is tightly wound on the reel in the direction indicated (viewed from the flange side):

Right Hand Reel: Cable-hose wound clockwise.
Left Hand Reel: Cable-hose wound counterclockwise.
11. Prewind the reel spring by grasping the end of the outer cable-hose and turning the reel a minimum of 3 turns in the direction indicated (viewed from the flange side).

Right Hand Reel: Wind reel clockwise.
Left Hand Reel: Wind reel counterclockwise.

CAUTION: Rotation in a direction opposite than described will damage the inner cable and reel spring.

If more tension is required, the reel can be prewound additional turns. The maximum turn capacities are:

Standard Reel: 16 total turns.
Cold Storage: 12 total turns.

Total turns = Prewind turns + Working turns.

CAUTION: Exceeding turn capacity of the reel will damage the inner cable and reel spring.
12. With the reel prewound, pull the hose ends down to the junction block. Fasten the hoses with the clamp bar and capscrew. See Figure 16.

WARNING: Do not let the reel unwind when connecting the cable-hose to the junction block.

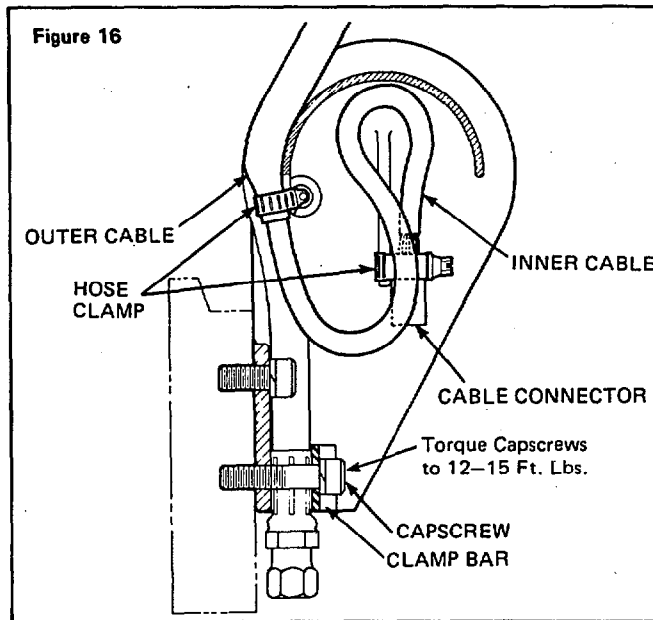

13. Connect the cable from the cable-hose to the junction block. Clamp the outer cable to the projection between the hoses with a hose clamp. See Figure 16. Position the hose clamp so it can be tightened through the hole in the side of the junction block. Route the inner cable through the junction block as shown. Fasten the male cable connector to the large projection with a hose clamp. Do not overtighten the clamp. The female cable connector must fit in the male connector. Join the connectors.
14. Connect the attachment hoses to the junction block. Be sure the hoses and their functions do not become interchanged. See Figure 17.
15. Operate the carriage up and down a few times to make sure the cable-hose tracks smoothly and no interference exists.

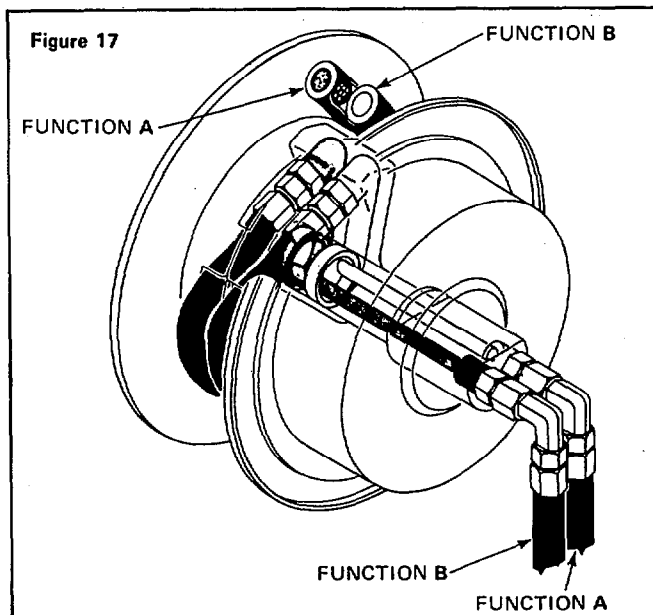

INNER CABLE REPLACEMENT

DISCONNECTING THE REEL

1. Disconnect the connectors at the junction block.
2. Remove the cable-hose from the junction block.



WARNING: Hold hoses firmly while disconnecting cable-hose from the junction block. Allow the reel spring to unwind slowly while maintaining tension on the loose cable-hose end. See Figure 18.

Figure 18

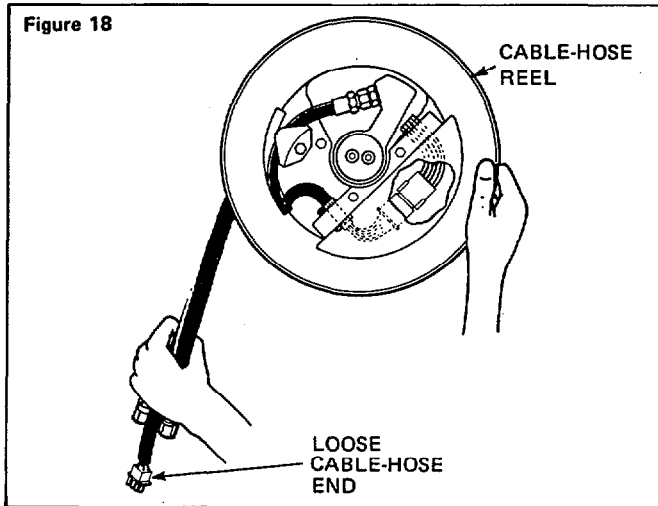

3. Remove the fixed cover from the mounting block and disconnect the cable connector. See Figure 3.
4. Disconnect the truck valve hoses from the shaft.
5. Remove the capscrews and lockwashers fastening the reel to the mounting pad. Remove the reel from the mast.

REEL DISASSEMBLY

1. Remove the nuts from the hub studs and lift off the rotating cover. See Figure 19.
2. Disconnect the reel outer cable connector from inner cable connector. See Figure 19.
3. Disconnect the hoses from the reel hub fittings.
4. Remove the four nuts and washers attaching the inner cable housing to the inner reel flange. See Figure 19.
5. Pull the reel flanges off the hub studs. Rotate the flanges slightly to free the inner cable connector.
6. Remove the mounting brackets and split the mounting blocks from the shaft. See Figure 19.
7. Separate the spring assembly from the inner cable housing. Slide the inner cable housing off the shaft. See Figure 19.

CAUTION: Do not allow the inner cable housing to rotate independently of its hub. Damage to the inner cable will occur if they are rotated. Use tape or wire to hold both from rotating. If either has been rotated, refer to the **Inner Cable Housing Timing** instruction on page 9.

Figure 19

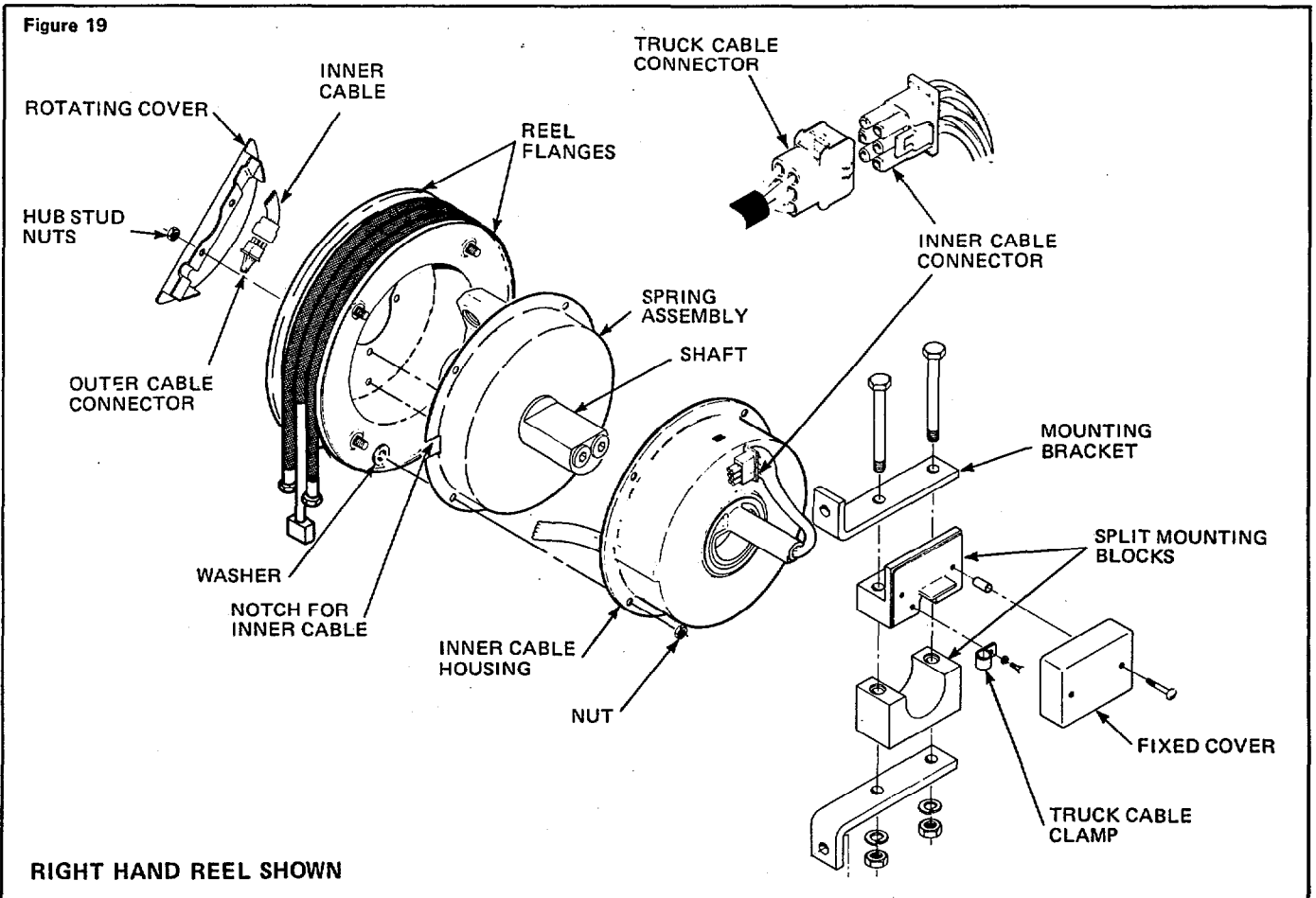

RIGHT HAND REEL SHOWN

INNER CABLE REPLACEMENT

NOTE: If a new Inner Cable Housing is being installed, delete this step and proceed to **Reel Reassembly**.

1. Insert a small diameter allen wrench under the lip of the divider plate. Grip the allen wrench with a pair of vise grips. Pull outward to remove the divider plate. See Figure 20.

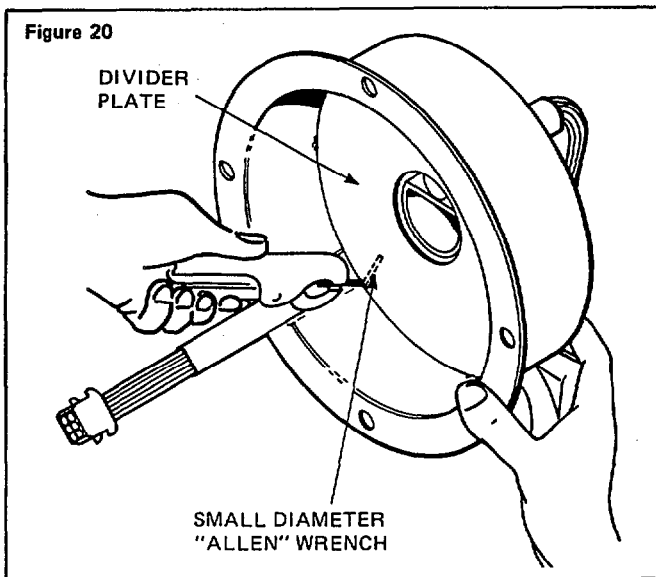

2. Remove the cable harness.
3. Place the new cable harness in the housing. Fit the cable (at its 90° bend) under the spring plate and around the pin. See Figure 21.

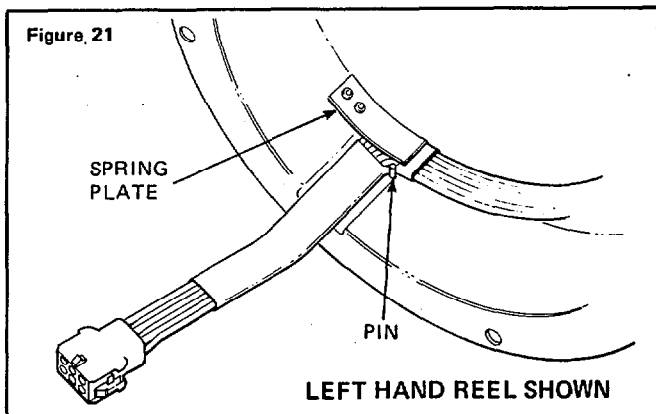

4. Wind the cable around the hub in the direction shown in Figure 22.
A Right or Left hand reel is determined as viewed from the flange side of the reel. See Figure 7.

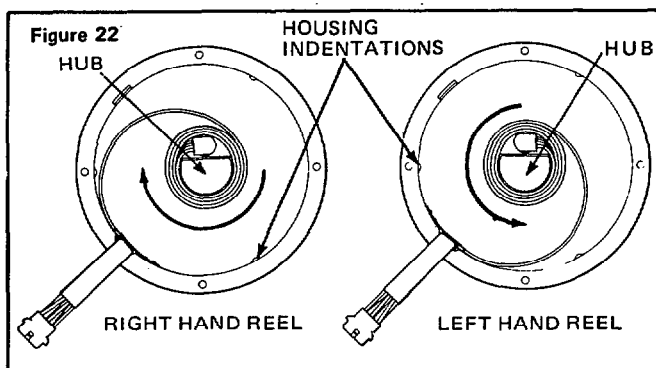

5. Place the divider plate inside the housing. Push the plate edge past the three housing indentations.

INNER CABLE HOUSING TIMING

1. Determine if the reel is a right hand or left hand model as viewed from the flange side of the reel. See Figure 7.
2. Position the cable container with the hub cable harness toward you. See Figure 23.
3. Hold the housing from rotating. Wind the hub until tight:
Right Hand Reel: Wind hub counterclockwise.
Left Hand Reel: Wind hub clockwise.
4. Rotate the hub back 1 revolution. This provides one safety turn in the wiring to prevent internal damage.
5. Use tape or wire to secure the hub to the housing. This will prevent either from rotating. The Inner Cable Housing is ready for further reel assembly.

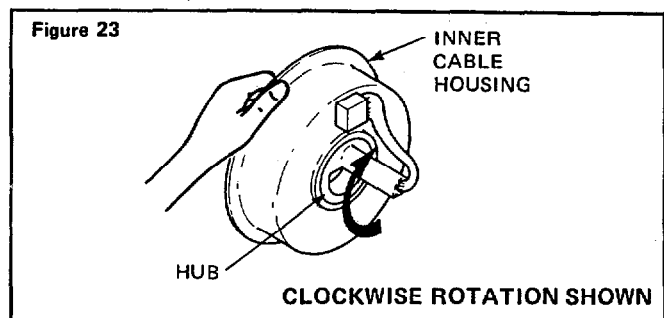

REEL REASSEMBLY

1. Fit the new inner cable housing over the shaft (do not rotate) and over the spring assembly. Be sure to fit the inner cable into the notch in the spring assembly. See Figure 19.
CAUTION: Do not allow the inner cable housing to rotate independently of its hub. Damage to the inner cable will occur if they are rotated. Use tape or wire to hold both from rotating. **If either has been rotated** refer to the **Inner Cable Housing Timing** instructions in the preceding section.
IMPORTANT: The spring assembly must be in its neutral position when fitted into the inner cable housing.
2. Install the split mounting blocks and mounting brackets. See Figure 19.
3. Fit the reel flanges onto the hub studs. Install the capscrews, washers, and nuts to fasten the reel flanges to the inner cable housing.
4. Connect inner and outer cable connectors.
5. Install the rotating cover and hub nuts. The inner cable must be laying flat in the flange depression and not pinched. Tighten the nuts.
6. Remount the reel on the truck.
7. Reconnect the inner cable connector to the truck cable at the mounting block. See Figure 19.
8. Attach the clamp to the truck cable and secure the clamp to the mounting block.

9. Install the fixed cover.

CAUTION: Overtightening the capscrews will damage the fixed cover.

10. Connect the truck valve hoses to the shaft.
11. Make sure the cable-hose is tightly wound on the reel in the direction indicated (viewed from the flange side):

Right Hand Reel: Cable-hose wound clockwise.

Left Hand Reel: Cable-hose wound counterclockwise.

A Right or Left hand reel is determined as viewed from the flange side of the reel. See Figure 7.

12. Prewind the reel spring by grasping the end of the outer cable and turning the reel a minimum of 3 turns in the direction indicated (viewed from the flange side):

Right Hand Reel: Wind reel clockwise.

Left Hand Reel: Wind reel counterclockwise.

CAUTION: Rotation in a direction opposite than described will damage the inner cable and reel spring.

If more tension is required, the reel can be prewound additional turns. The maximum turn capacities are:

Standard Reel: 16 total turns.

Cold Storage Reel: 12 total turns.

Total turns = Prewind turns + Working turns.

CAUTION: Exceeding turn capacity of the reel will damage the inner cable and reel spring.

13. With the reel prewound, pull the hose ends down to the junction block. Fasten the hoses with the clamp bar and capscrew. See Figure 24.



WARNING: Do not let the reel unwind when connecting the cable-hose to the junction block.

14. Connect the cable from the cable-hose to the junction block. Clamp the outer cable to the projection between the hoses with a hose clamp. See Figure 24. Position the hose clamp so it can be tightened through the hole in the side of the junction block. Route the inner cable through the junction block as shown. Fasten the male cable connector to the large projection with a hose clamp. Form the hose clamp around the connector. Do not overtighten the clamp. The female cable connector must fit in the male connector. Join the connectors.
15. Connect the attachment hoses to the junction block. Be sure the hoses and their functions do not become interchanged. See Figure 25.

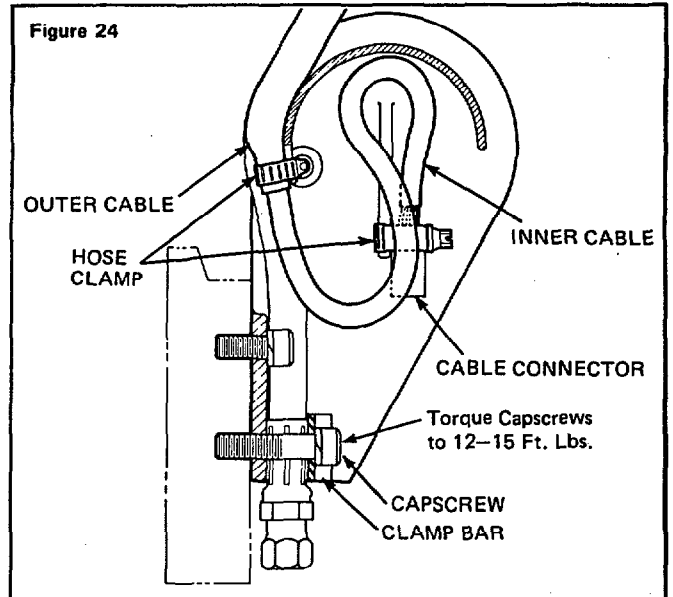

16. Operate the carriage up and down a few times to make sure the cable-hose tracks smoothly and no interference exists.

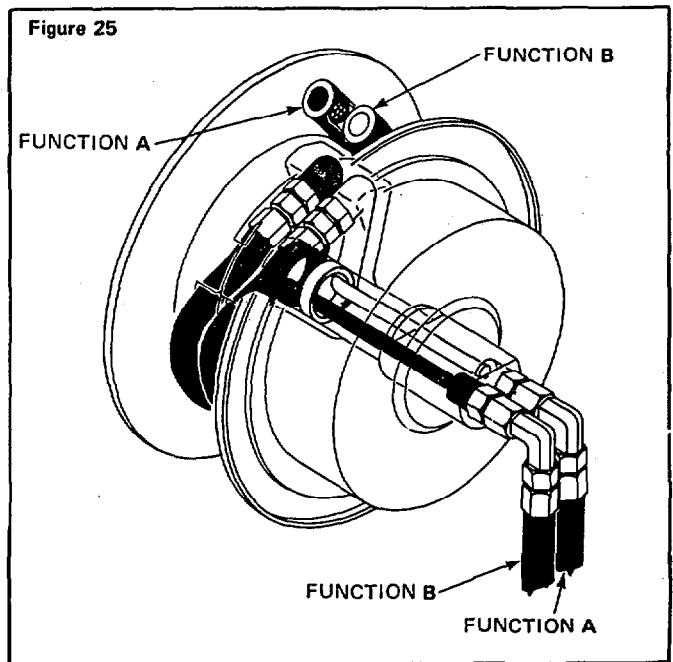

OUTER CABLE-HOSE REPLACEMENT

1. Disconnect the old outer cable-hose from the attachment cable at the junction block.



WARNING: Hold cable-hose firmly while disconnecting cable from the junction block. Allow the reel spring to unwind slowly while maintaining tension on the loose cable end. See Figure 26.

2. Disconnect the old cable-hose from the junction block.
3. Disconnect the hoses from the reel hub fittings. See Figure 27.

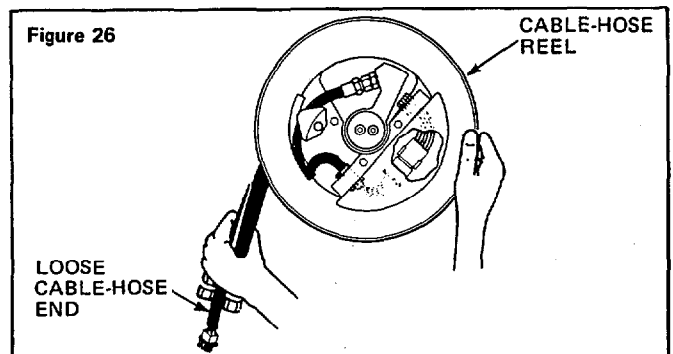

4. Remove the two hub nuts securing the rotating cover to outer flange. Remove the rotating cover. See Figure 27.
5. Remove the cable clamps. Discard the old outer reel cable-hose. See Figure 27.
6. Connect the new hoses to the reel hub fittings.

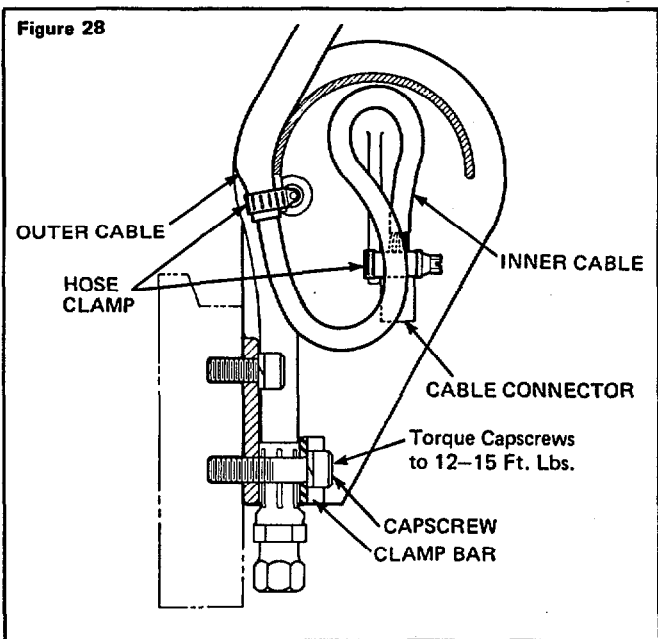
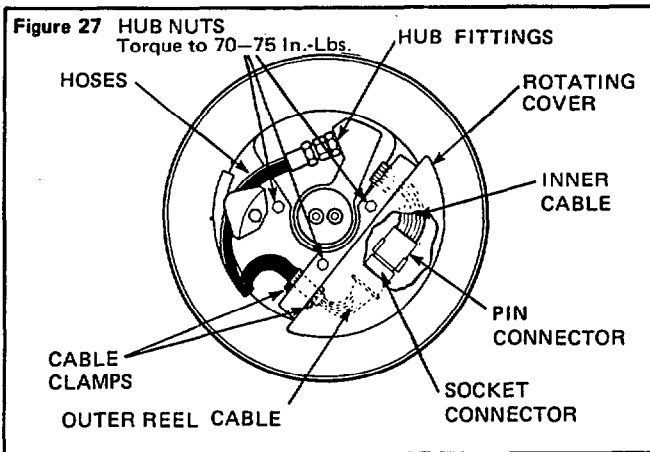

7. Join new outer reel cable connector to the inner cable connector using the established connection pattern. See page 1.
8. Fit the cable clamps to the outer cable and secure them on each side of the rotating cover. See Figure 27.
9. Install rotating cover and hub nuts. The inner cable must be laying flat in the flange depression and not pinched. Tighten nuts to a torque of 70-75 in.-lbs. See Figure 27.
10. Wind the new cable-hose completely onto reel in direction indicated (viewed from the flange side).

Right Hand Reel: Wind cable-hose clockwise.
Left Hand Reel: Wind cable-hose counterclockwise.

A Right or Left hand reel is determined as viewed from the flange side of the reel. See Figure 7.

11. Prewind reel spring by grasping the end of the outer cable-hose and turning the reel a minimum of 3 turns in direction indicated (viewed from the flange side).

Right Hand Reel: Wind reel clockwise.
Left Hand Reel: Wind reel counterclockwise.

CAUTION: Rotation in a direction opposite than described will damage the inner cable and reel spring.

If more tension is required the reel can be prewound additional turns. The maximum turn capacities are:

- Standard Reel:** 16 total turns.
- Cold Storage Reel:** 12 total turns.

$$\text{Total Turns} = \text{Prewind turns} + \text{Working turns}$$

CAUTION: Exceeding turn capacity of the reel will damage the inner cable and reel spring.

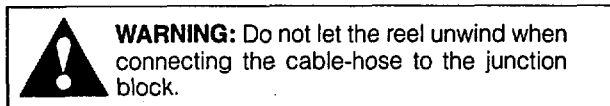

12. With the reel prewound, pull the hose ends down to the junction block. Fasten the hoses with the clamp bar and capscrew. See Figure 28.

13. Connect the cable from the cable-hose to the junction block. Clamp the outer cable to the projection between the hoses with a hose clamp. See Figure 28. Position the hose clamp so it can be tightened through the hole in the side of the junction block. Route the inner cable through the junction block as shown. Fasten the male cable connector to the large projection with a hose clamp. Form the hose clamp around the connector. Do not overtighten the clamp. The female cable connector must fit in the male connector. Join the connectors.
14. Connect the attachment hoses to the junction block. Be sure the hoses and their functions do not become interchanged. See Figure 29.
15. Operate the carriage up and down a few times to make sure the cable-hose tracks smoothly and no interference exists.

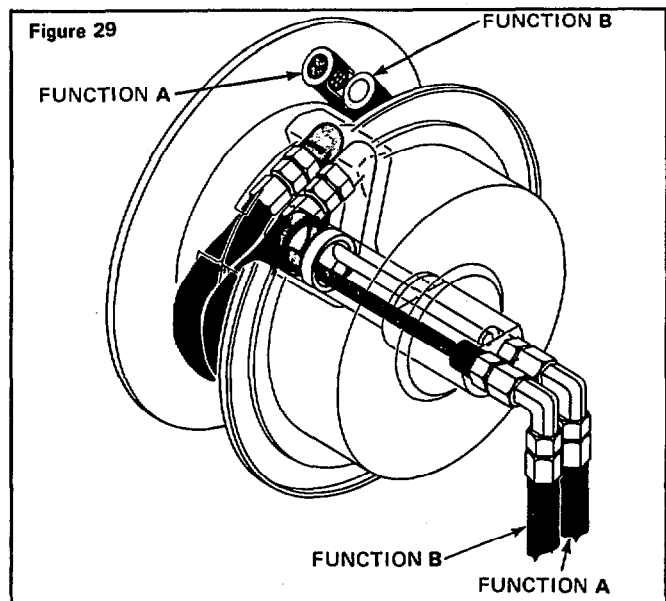

TROUBLESHOOTING GUIDE

PROBLEM	PROBLEM CAUSE	SOLUTION
Excessive wear on cable-hose.	Cable-Hose reel and junction block are not in proper alignment.	Align the junction block and cable-hose reel properly. They must be on the same center line and mounted squarely to each other. See Figure 4.
	Cable-Hose reel flanges damaged.	Repair or replace damaged parts.
Cable-Hose jumps off reel during operation.	Incorrect prewind of spring.	Prewind spring, see page 4, steps 21 through 24.
	Cable-Hose not aligned with junction block.	Align junction block with cable-hose reel. See Figure 4.
Cable-Hose binds during operation.	Cable-Hose reel spring is broken.	Replace the spring.
	Back-up ring in hub working between shaft and hub.	Replace the back-up rings.
	Scored seal areas.	Replace the damaged hub and/or use an emery cloth to remove the nicks from the shaft.
Electrical malfunction.	The same pattern for cable connections has not been used at all locations.	Make sure pin and cable connectors use the same pattern at all locations.
	Electrical short in the reel cable, truck or attachment cable.	See Electrical Troubleshooting Guide.
Cable-Hose Reel leaks at hub.	Damaged O-ring seals in the rotating hub.	Replace all seals. When a cable-hose reel requires replacement of any one of the O-rings or back-up rings, it is important that all the seals be replaced. If all the O-rings and back-up rings are not replaced at the same time, the reel will only have to be disassembled again in a short period of time to replace the older seals. The seal kit offered by Cascade includes all of the O-rings and back-up rings necessary to rebuild one hose reel. Order appropriate Seal Kit.
	Loose or damaged fittings.	Tighten or replace damaged fittings.
	Scored seal areas.	Replace the damaged shaft and/or use emery cloth to remove the nicks from the shaft.
Inner Cable Housing wire breaks inside housing.	Excessive mast height.	Cable-Hose reel cannot be used in this application. The maximum turn capacity is being exceeded.
	Cable-Hose reel wound backwards.	Replace Inner Cable Housing. Wind reel in direction indicated in Inner Cable Housing Replacement Instructions.
	Service life of wire has been exceeded.	Replace Inner Cable Housing.
	Cold Storage reel is being used in a Standard reel application. The maximum turn capacity of the reel has been exceeded.	Determine if the reel is a Standard or Cold Storage reel. See page 5. Do not exceed reels turn capacity shown on page 5.

2614.2-120/2

ELECTRICAL TROUBLESHOOTING GUIDE

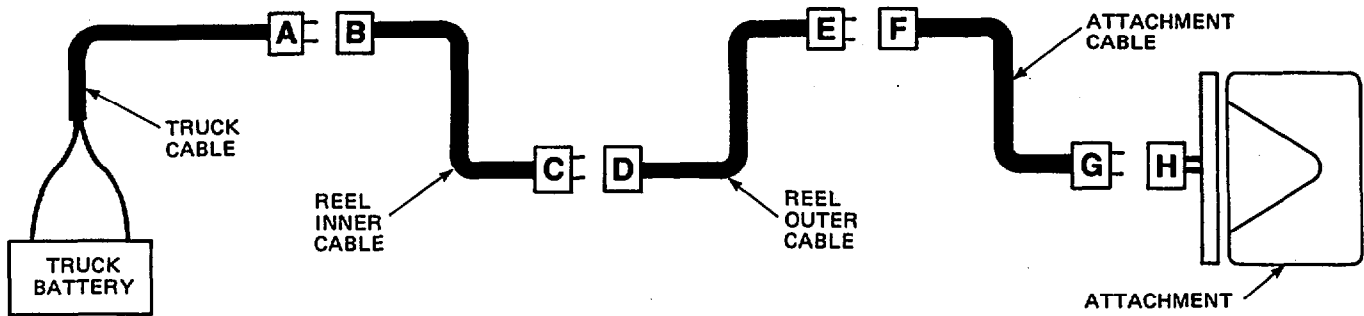

Using the accompanying electrical diagram and the following instructions, locate an electrical short. When using an ohmmeter to check for continuity, follow the instructions with your meter. Make sure that electrical power is disconnected when checking continuity.

1. Connect cable connector A to cable connector F (to isolate the entire cable reel). Operate the attachment.

NOTE: Do not operate the mast.

 - a. If none of the attachment functions operate:
 - Disconnect cable connector A from cable connector F.
 - Use an ohmmeter to check the continuity of the attachment cable (between connectors F and G). If the cable checks OK, the truck cable is faulty and should be replaced. Refer to your truck Service Manual.
 - b. If some attachment functions respond and others do not, the pins and/or sockets in the connectors are at fault and should be replaced. Recheck attachment operation after repair.
 - c. If all attachment functions operate correctly, reconnect the cables as shown in the diagram and proceed to Step 2.

2. Connect cable connector A to cable connector D (to isolate the reel inner cable). Operate the attachment.

NOTE: Do not operate the mast.

 - a. If none of the attachment functions operate, the reel outer cable is faulty and should be replaced. For replacement instructions, refer to page 9.
 - b. If some attachment functions respond and others do not, the pins and/or sockets in the connectors are at fault and should be replaced. Recheck attachment operation after repair.
 - c. If all attachment functions operate correctly, reconnect the cables as shown in the diagram and proceed to Step 3.

3. Connect cable connector C to cable connector F (to isolate the reel outer cable). Operate the attachment.

NOTE: Do not operate the mast.

 - a. If none of the attachment functions operate, the reel inner cable is faulty and should be replaced. For replacement instructions, refer to page 8.
 - b. If some attachment functions respond and others do not, the pins and/or sockets in the connectors are at fault and should be replaced. Recheck attachment operation after repair.

CABLE-HOSE LENGTH CALCULATIONS

H = Total lift height
D = Distance from centerline of reel to junction block.

1. When **H** is equal to, or greater than $2 \times \mathbf{D}$, the correct cable-hose length is: $\mathbf{H} - \mathbf{D} + 38$ inches
2. When **H** is less than $2 \times \mathbf{D}$, the correct cable length is: $\mathbf{D} + 38$ inches

Example

H = 286"
D = 96"
 $286" - 96" = 190" + 38" = 228"$
 Correct cable-hose length

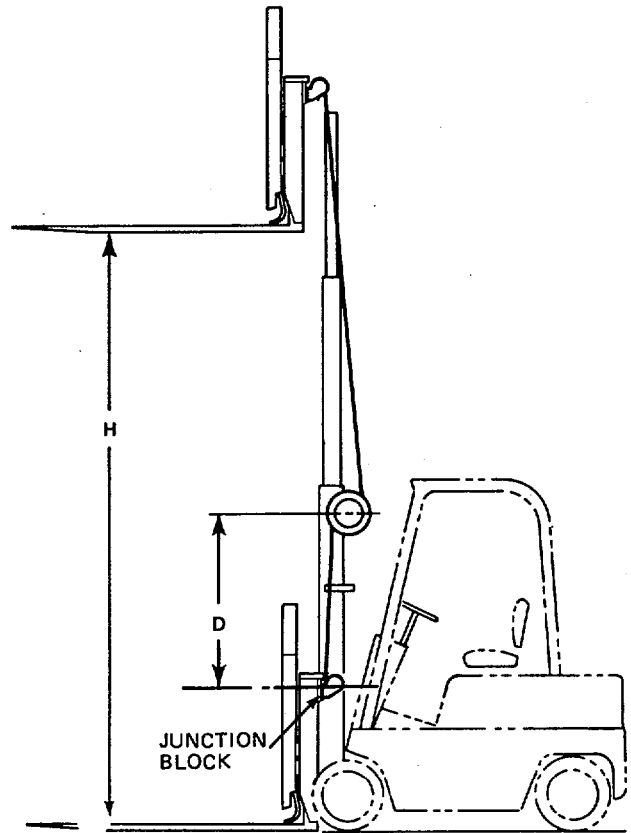

CABLE-HOSE PREPARATION DETAIL

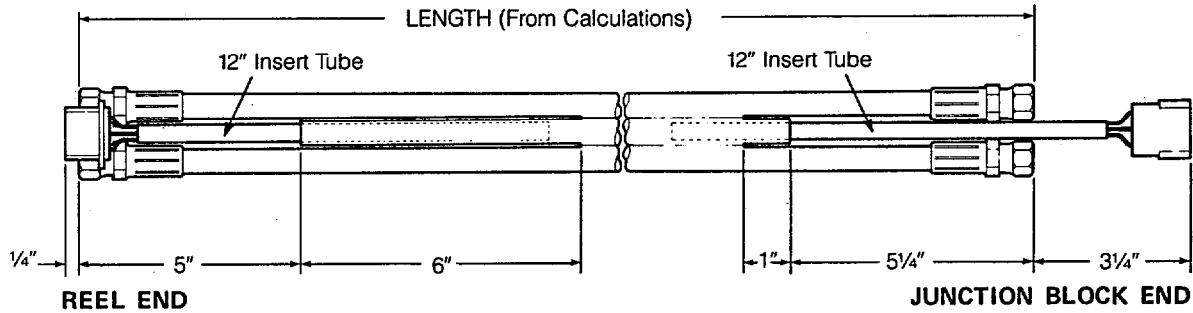

WORKSHEET

1. **H**=(enter mast's lift height here) _____
2. **D**=(enter distance between junction block and center of reel with carriage completely lowered) _____
3. Multiply **D** by 2 _____
4. If line 1. is less than line 3., the cable-hose length should be:
 D (line 2.) _____
 + 38 inches 38"
 Cable-Hose Length = _____

If line 1. is equal to or larger than line 3., the cable-hose length should be:

H (line 1.) _____
 - **D** (line 2.) _____
 + 38 inches 38"
 Cable-Hose Length = _____

CABLE-HOSE REELS

RIGHT HAND REEL SHOWN

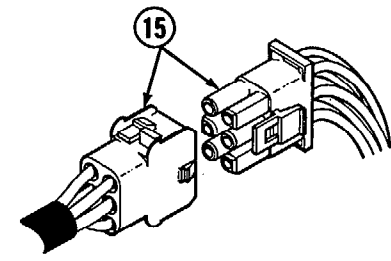
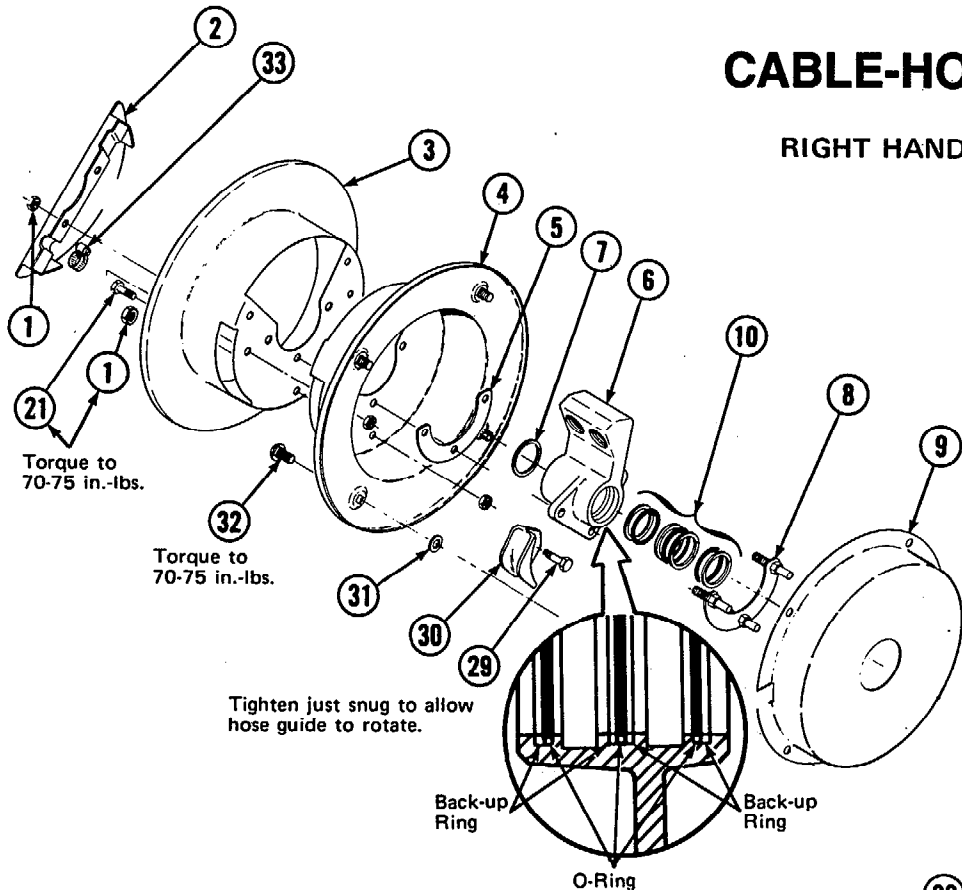

Torque to 35-40 ft.-lbs.

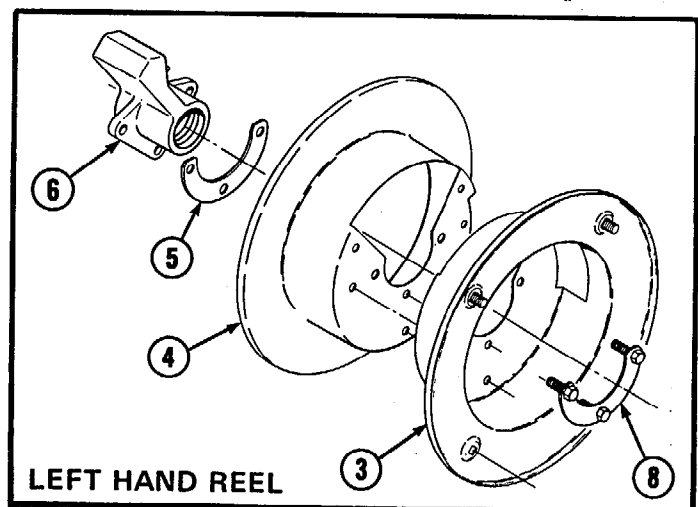
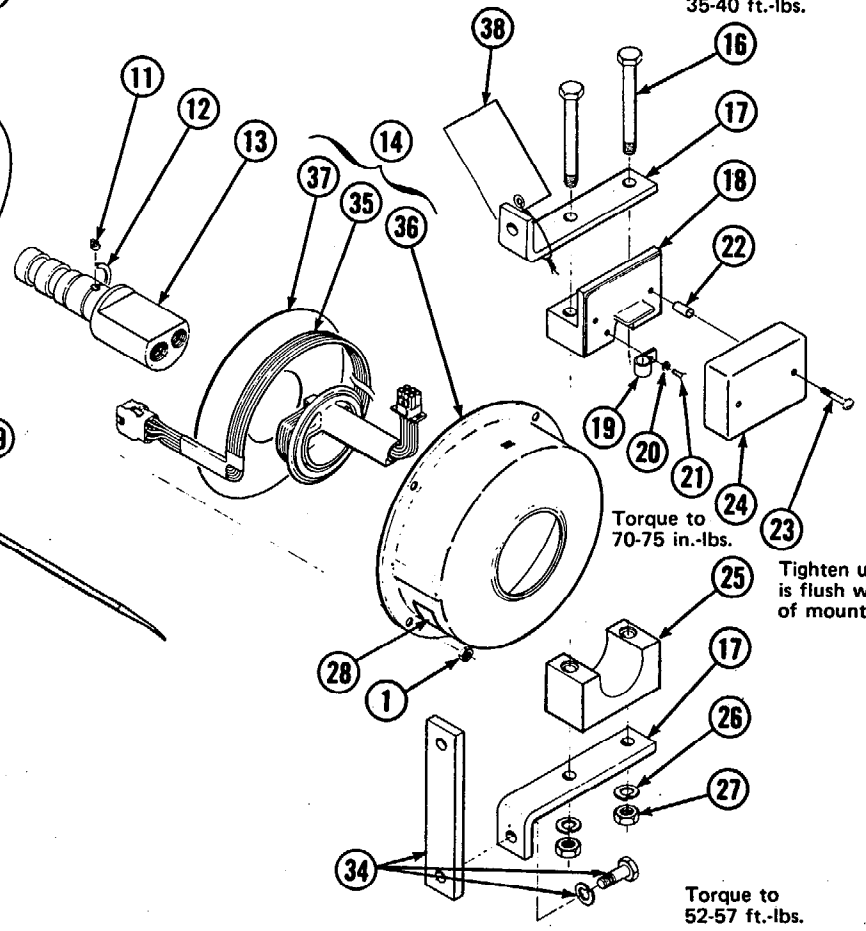

CABLE-HOSE REELS

Items that vary according to model

REF	QTY.	11.5" Diameter		14.5" Diameter		16.5" Diameter		DESCRIPTION
		HC2R	HC2L	HC8R	HC8L	HC6R	HC6L	
		677834	677835	677836	677837	677838	677839	Cable-Hose Reel Assembly
3	1	645979	645990	645988	646067	646070	646071	Flange
4	1	645990	645979	646067	645988	646071	646070	Flange
28	1	677846	677847	677848	677849	677850	677851	Nameplate

2614d-82/2

Items common to all models

REF	QTY	PART NO.	DESCRIPTION	REF	QTY.	PART NO.	DESCRIPTION
1	11	645986	Locking Nut, 1/4 NC	20	1	6286	Lockwasher, 1/4 ID
2	1	659898	Rotating Cover - Left Hand	21	4	3551	Capscrew, 1/4 NC x .50
	1	659876	Rotating Cover - Right Hand	22	2	663886	Tube
5	1	659880	Spacer	23	2	659887	Machine Screw, 1/4 NC x 1.50
6	1	677860	Hub	24	1	659886	Fixed Cover
7	1	3135	Snap Ring	25	1	659884	Lower Mounting Block
8	1	659881	Bracket	26	2	6290	Lockwasher, 1/2 ID
9	1	664886	Spring Assembly - Right Hand	27	2	5904	Nut, 1/2 NC
	1	664885	Spring Assembly - Left Hand	29	1	3556	Capscrew, 1/4 NC x 1.25
10	1	677833	Shaft Seal Kit	30	2	646075	Hose Guide
11	1	659917	Spring Retainer	■ 31	4	6228	Washer, 1/4 ID
12	1	675610	Snap Ring	32	4	659889	Capscrew
13	1	677858	Shaft	33	2	659875	Clamp
14	1	669651	Cable Service Kit - Right Hand	34	1	661031	Mounting Kit
	1	669652	Cable Service Kit - Left Hand	■ 35	1	669654	Cable Harness
● 15	1	660414	Connector Kit	■ 36	1	669647	Cable Housing Assembly - Right Hand
16	2	3667	Capscrew, 1/2 NC x 5.00	■ 36	1	669648	Cable Housing Assembly - Left Hand
17	2	659888	Mounting Bracket	■ 37	4	659882	Divider Plate
18	1	659885	Upper Mounting Bracket	38	1	667898	Caution Tag
19	1	659890	Clip	39	1	674424	O-Ring Extractor Tool
				★		676314	Service Tool Kit

2614b-80/2

- Connector Kit includes 1 Socket Connector Housing (661680) and 6 Socket Connectors (661681); 1 Pin Connector Housing (661678) and 6 Pin Connectors (661679).
- Included in Cable Service Kit (Ref. No. 14).
- ★ Includes (1) crimping tool and (1) pin extractor tool.

CABLE-HOSE REELS Cold Storage Applications

RIGHT HAND REEL SHOWN

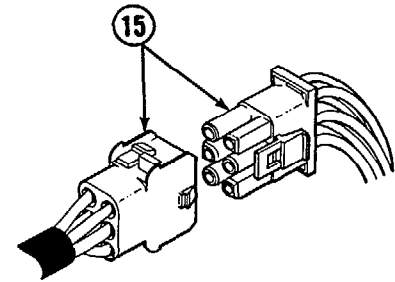
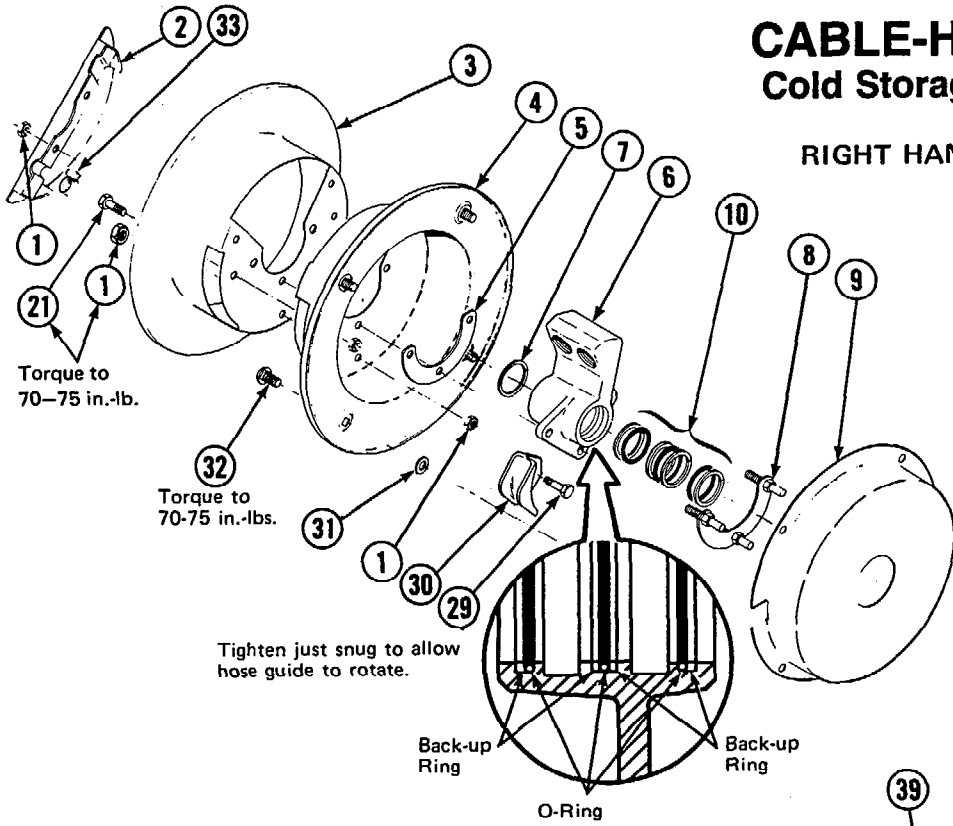

Torque to 35-40 ft.-lbs.

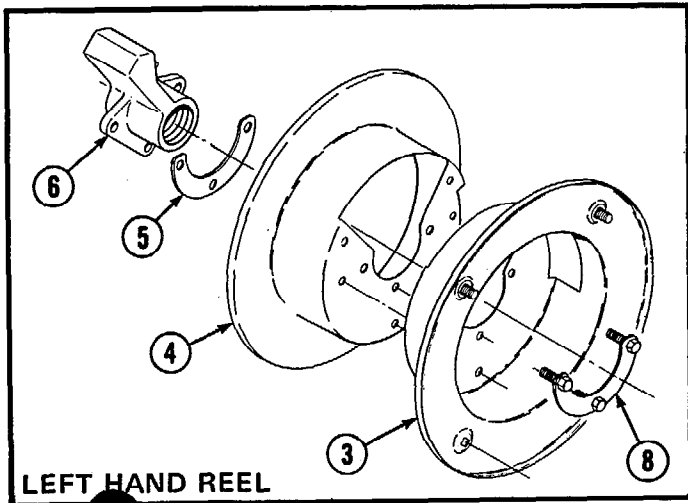
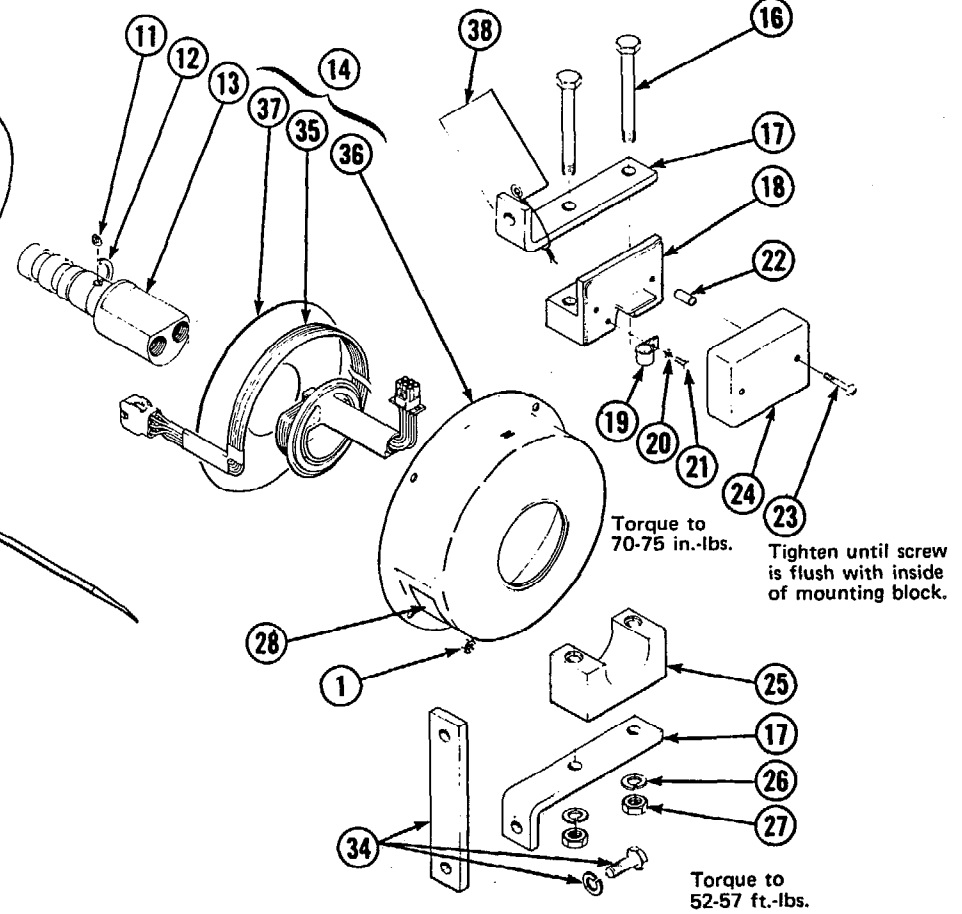

CABLE-HOSE REELS

Cold Storage Applications

Items that vary according to model

REF	QTY.	11.5" Diameter		14.5" Diameter		16.5" Diameter		DESCRIPTION
		HC2R	HC2L	HC8R	HC8L	HC6R	HC6L	
		677840	677841	677842	677843	677844	677845	Cable-Hose Reel Assembly
3	1	645979	645990	645988	646067	646070	646071	Flange
4	1	645990	645979	646067	645988	646071	646070	Flange
28	1	677852	677853	677854	677855	677856	677857	Nameplate

2614e

Items common to all models

REF	QTY	PART NO.	DESCRIPTION	REF	QTY.	PART NO.	DESCRIPTION
1	11	645986	Locking Nut, 1/4 NC	20	1	6286	Lockwasher, 1/4 ID
2	1	659898	Rotating Cover - Left Hand	21	4	3551	Capscrew, 1/4 NC x .50
	1	659876	Rotating Cover - Right Hand	22	2	663886	Tube
5	1	659880	Spacer	23	2	659887	Machine Screw, 1/4 NC x 1.50
6	1	677860	Hub	24	1	659886	Fixed Cover
7	1	3135	Snap Ring	25	1	659884	Lower Mounting Block
8	1	659881	Bracket	26	2	6290	Lockwasher, 1/2 ID
9	1	664886	Spring Assembly - Right Hand	27	2	5904	Nut, 1/2 NC
	1	664885	Spring Assembly - Left Hand	29	1	3556	Capscrew, 1/4 NC x 1.25
10	1	677833	Shaft Seal Kit	30	2	646075	Hose Guide
11	1	659917	Spring Retainer	■ 31	4	6228	Washer, 1/4 ID
12	1	675610	Snap Ring	32	4	659889	Capscrew
13	1	677858	Shaft	33	2	659875	Clamp
14	1	669718	Cable Service Kit - Right Hand	34	1	661031	Mounting Kit
	1	669719	Cable Service Kit - Left Hand	■ 35	1	665539	Cable Harness
● 15	1	660414	Connector Kit	■ 36	1	669647	Cable Housing Assembly - Right Hand
16	2	3667	Capscrew, 1/2 NC x 5.00	■ 36	1	669648	Cable Housing Assembly - Left Hand
17	2	659888	Mounting Bracket	■ 37	4	659882	Divider Plate
18	1	659885	Upper Mounting Bracket	38	1	667898	Caution Tag
19	1	659890	Clip	39	1	674424	O-Ring Extractor Tool
				★		676314	Service Tool Kit

2614c-81/2

- Connector Kit includes 1 Socket Connector Housing (661680) and 6 Socket Connectors (661681); 1 Pin Connector Housing (661678) and 6 Pin Connectors (661679).
- Included in Cable Service Kit (Ref. No. 14).
- ★ Includes (1) crimping tool and (1) pin extractor tool.

JUNCTION BLOCK GROUP

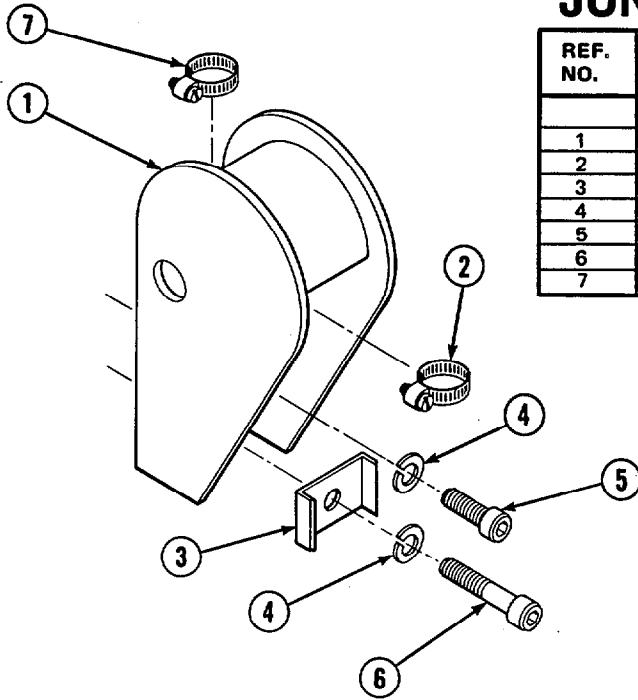

REF. NO.	QTY.	PART NO.	DESCRIPTION
		659859	Junction Block Assembly
1	1	659828	Junction Block
2	1	662139	Clamp
3	1	659851	Bar
4	2	6372	Lockwasher
5	1	4472	Cap screw
6	1	4468	Cap screw
7	1	662138	Clamp

MOUNTING GROUP

REF. NO.	QTY.	RIGHT HAND PART NO.	LEFT HAND PART NO.	DESCRIPTION
		665330	665331	Mounting Group
1	1	664084	664085	Mounting Bracket
2	3	6288	6288	Lockwasher
3	3	3601	3601	Cap screw
4	2	6290	6290	Lockwasher
5	2	5904	5904	Nut
6	1	662293	662293	Bar

These mounting groups designed for Cascade roller triple lift masts.

For Cascade Quad masts and masts other than Cascade, use Mounting Group 661031.

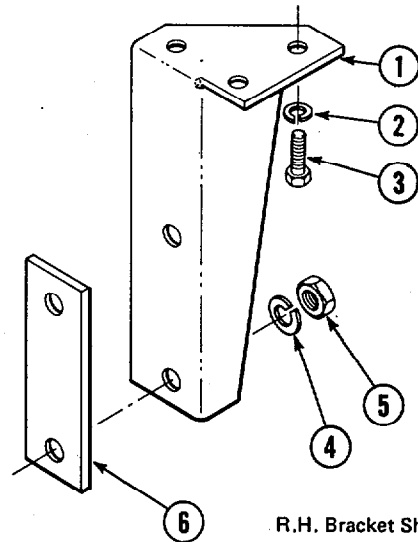

R.H. Bracket Shown

FITTING GROUP

HC2R, HC2L, HC6R, HC6L, HC8R, HC8L Models	
CATALOG ORDER NO.	FITTING SIZE
646062	No. 6
The group includes four straight O-Ring connectors and two Swivel 90° Elbows. This permits hose connections into and out of the reel. All necessary electrical connectors are included with the reel.	

CABLE-HOSES

CATALOG ORDER NO.	HOSE LENGTH (TOTAL)		HOSE SIZE (No. 6 Fittings)
	STANDARD	COLD STRG.	
665678	128"	128"	No. 5
665679	231"	231"	
665680	316"		
660431	118"	118"	No. 6
665681	212"	212"	
665682	284"		
665683		239"	

The cable is constructed of 18 ga., six conductor wire with six electrical connectors.

Do you have questions you need answered right now? Call your nearest Cascade Service Department.

Cascade Corporation
P.O. Box 20187
2201 N.E. 201st Ave.
Troutdale, OR 97060
Tel.: 503/666-1518
800-227-2233 (Toll Free)
Telex: 590480
Cable: Cascade Ptl
FAX: 1-503-665-0301

**Cascade N.V.
European Headquarters**
P.O. Box 50086
1305 AB Almere-Haven
Achterwerf 240
1357 CB Almere-Haven
The Netherlands
Tel.: 03240-92911
Telex: 40838 case nl
FAX: 011-31-3240-92286

**Cascade Scandinavia
Hydraulik A.B.**
Muskötgatan 17-(E.8-9)
252 55 Helsingborg
Sweden
Tel.: 042-151135
Telex: 72565 caschbg s

Cascade GmbH
Klosterhofweg 52
4050 Mönchengladbach 3
B.R. Deutschland
Tel.: 02166-602091
Telex: 852812 casc d

Cascade Hydraulics Ltd.
7615 Kimbel Street
Mississauga, Ontario
Canada L5S-1A8
Tel.: 416/677-9695
Direct Parts Line:
416/677-9686
416/677-9684
Te/Ac: 06-968715

**Cascade Materials Handling
(Aust.) Pty. Ltd.
(Incorporated in N.S.W.)**
121 Long Street
Smithfield, N.S.W. 2164
Australia
Tel.: 02-604-6222
Te/Ac: (790)24302
Cable: Cascaus
FAX: 011-61-2-609-2742

**Cascade Materials Handling
(Aust.) Pty. Ltd.**
44E Winton Road
Clayton, Victoria 3168
Australia
Tel.: 03-543-4344
Cable: Casmel

Cascade Japan Ltd.
4-1, 1-Chome,
Shin Senri Higashimachi
Toyonaka, Osaka 565
Japan
Tel.: 06-835-2900
Tel/Ac: 781-5287115 Cascade J
Cable: Cascadecfe, Osaka
FAX: 011-816-835-2905

Cascade (UK) Ltd.
15, Orgreave Crescent
Dore House Industrial Estate
Handsworth
Sheffield S13 9NQ
England
Tel.: 0742-697524/5/6/7
Telex: 547254 cascsh g

Cascade Hispania S.A.
Avenida De La Fabregada, 7
Hospitalet De Llobregat
Barcelona
Spain
Tel.: 93-3355158
Telex: 54018 casc e

**Cascade N.V.
Benelux Sales and Service**
P.O. Box 170
1110 AD Diemen
Weesperstratt 110
1112 AP Diemen
The Netherlands
Tel.: 020-906411
Telex: 14495 casc nl

Cascade France S.A.R.L.
11, rue Jean Charcot
Zone Industrielle Sud
B.P. 22
91421 Morangis Cedex
France
Tel.: (1)69091139
Telex: cascade 690016f

Cascade (Africa) Pty. Ltd.
P.O. Box 625
15 Power Street
Isando 1600
South Africa
Tel.: 011-974-5611/2/3/4/5
Telex: 4-29718 S.A.

