



Installation Instructions

100C Fork Positioner Tube Group 6124925

This document shows the installation of a new tubes and hoses to replace the cylinder supply hoses.

- 1 Remove the attachment from the truck.
- 2 Remove the sideshift cylinder anchor bracket.
- 3 Remove the hoses from the valve and cylinders.
- 4 Install the fittings and tubes to the bulkhead brackets. Install the tubes to the valve fittings
- 5 Weld the bulkhead brackets to the frame vertical side plates.
- 6 Install the hoses to the cylinders and bulkhead bracket fittings.
- 7 Install the new sideshift cylinder anchor bracket and bearings to the frame and sideshift cylinder. The bearings locate between the frame and cylinder anchor bracket.
- 8 Reinstall the attachment on the truck.

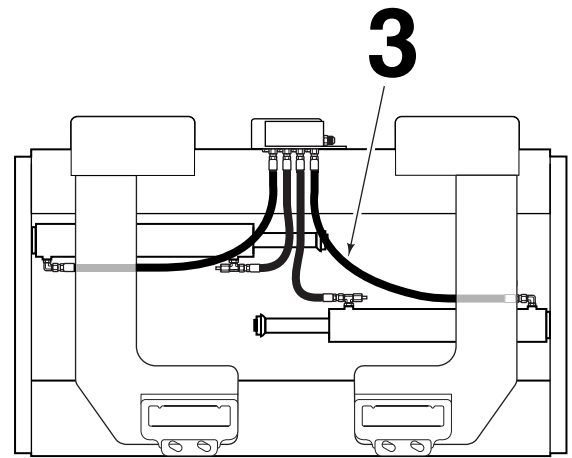

Back View

FP0747.eps

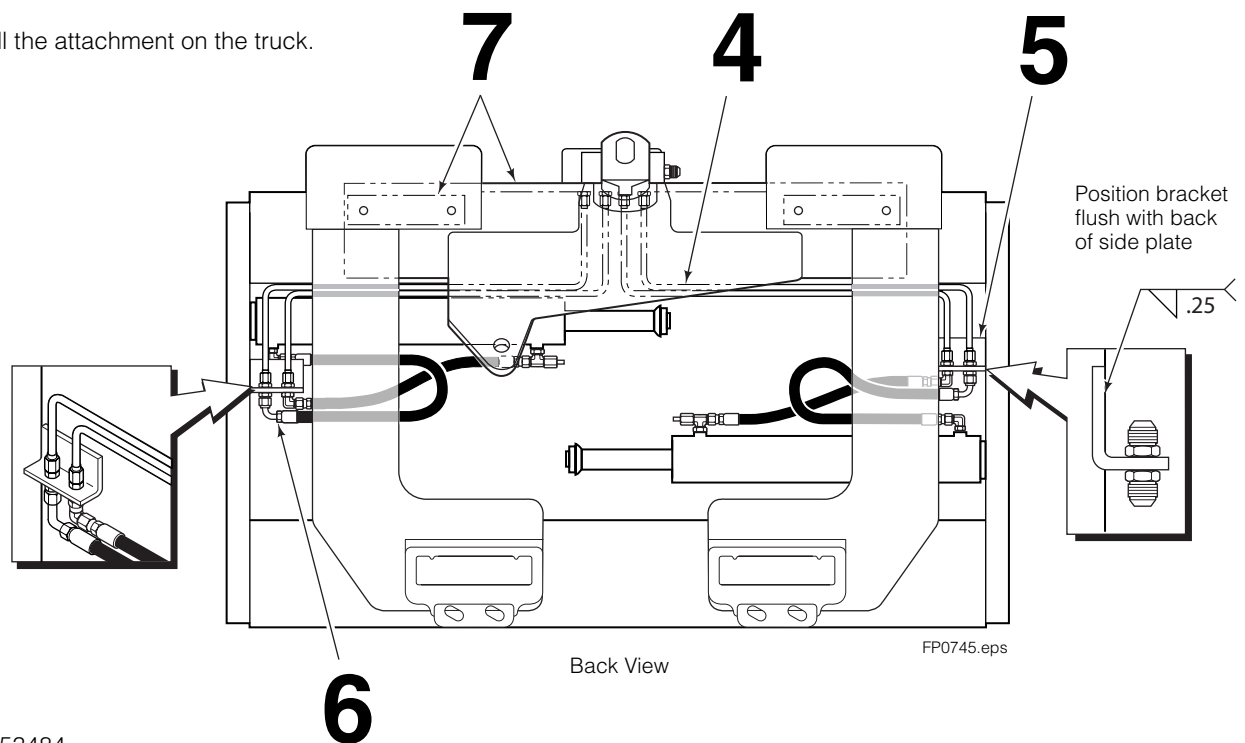

Back View

FP0745.eps

Part No. 6053484

cascade[®]
corporation

For Technical Support . . .

Call: 1-800-227-2233 Fax: 1-888-329-8207
Internet: www.cascorp.com
Write: Cascade Corporation, PO Box 20187, Portland, OR 97294

To Order Parts . . .

Call: 1-888-227-2233 Fax: 1-888-329-0234
Internet: www.cascorp.com
Write: Cascade Corporation, 2501 Sheridan Ave., Springfield, OH 45505

Tube Conversion Kit

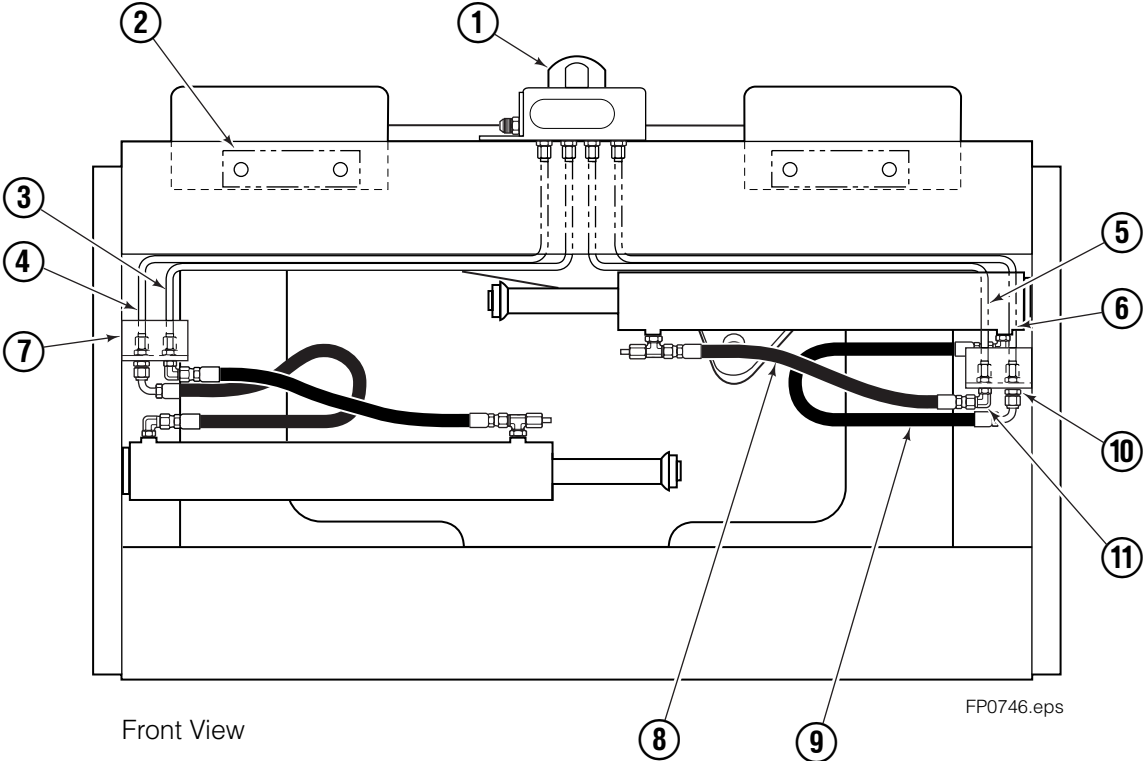

REF	QTY	PART NO.	DESCRIPTION
		6124925	Tube Conversion Kit
1	1	6123817	Anchor Bracket
2	2	6123777	Bearing
3	1	6124873	Tube
4	1	6124871	Tube
5	1	6124869	Tube
6	1	6124864	Tube
7	2	6124945	Bracket
8	2	381146	Hose, 26 in.
9	2	359926	Hose, 34.25 in.
10	2	2375	Fitting, 6-6
11	2	2453	Fitting, 6-6