

# **S**ERVICE MANUAL

---

## ***D-Series***

### ***Carton Clamps***

***This manual applies to attachment  
serial numbers:***

208910 through 209012,  
670232 through 678933

***Manual Number 670487-R4A***

**cascade<sup>®</sup>  
corporation**

Cascade is a Registered Trademark of Cascade Corporation

	Page		Page
<b>INTRODUCTION, Section 1</b>		<b>SERVICE, Section 5</b>	
Introduction, 1.1	1	Clamp Removal, 5.1	21
Special Definitions, 1.2	1	Arms, 5.2	22
<b>INSTALLATION, Section 2</b>		Arm Assemblies – Removal, Installation, 5.2-1	22
Truck System Requirements, 2.1	2	Contact Pad Rotation, Replacement, 5.2-2	23
Recommended Hydraulic Supply Options, 2.2	3	Arm Service, Eccentric Pivot Pins, 5.2-3	23
Installation Procedure, 2.3	4	Arm Service, Straight Pivot Pins, 5.2-4	24
<b>PERIODIC MAINTENANCE, Section 3</b>		Contact Pad, Stabilizer Repair, 5.2-5	25
100-Hour Maintenance, 3.1	9	Contact Pad Camber Adjustment, 5.2-6	26
500-Hour Maintenance, 3.2	9	Arm Bearings – Replacement, Shimming, 5.2-7	27
1000-Hour Maintenance, 3.3	9	Valve, 5.3	28
2000-Hour Maintenance, 3.4	9	Valve Removal, Installation, 5.3-1	28
<b>TROUBLESHOOTING, Section 4</b>		Eliminating Regeneration Circuit, 5.3-2	28
General Procedures, 4.1	10	Valve Service, 5.3-3	29
Truck System Requirements, 4.1-1	10	Cylinders, 5.4	30
Tools Required, 4.1-2	10	Cylinder Removal, Installation, 5.4-1	30
Troubleshooting Chart, 4.1-3	11	Cylinder Disassembly, 5.4-2	31
Troubleshooting Carton Clamp Loads, 4.1-4	12	Cylinder Inspection, 5.4-3	31
Plumbing, 4.2	14	Cylinder Reassembly, 5.4-4	32
Hosing Diagram, Clamp Circuit, 4.2-1	14	Base Unit, 5.5	33
Hosing Diagram, Sideshift Circuit, 4.2-2	15	Frame, Mounting Plate Replacement, 5.5-1	33
Hydraulic Circuit, 4.2-3	16	Solenoid Valve, 5.6	35
Clamp Function, 4.3	17	Coil Service, 5.6-1	35
Supply Circuit Test, 4.3-1	17	Valve Service, 5.6-2	35
Clamp Circuit Pressure Test, 4.3-2	17	<b>SPECIFICATIONS, Section 6</b>	
Valve Test, 4.3-3	18	Specifications, 6.1	36
Cylinder Test, 4.3-4	18	Hydraulics, 6.1-1	36
Sideshift Function, 4.4	19	Auxiliary Valve Functions, 6.1-2	36
Supply Circuit Test, 4.4-1	19	Truck Carriage, 6.1-3	36
Sideshift Circuit Test, 4.4-2	19	Torque Values, 6.1-4	37
Electrical Circuit, 4.5	20		

## 1.1 Introduction

This Manual provides the Installation, Periodic Maintenance, Troubleshooting, Service and Specifications for Cascade D-Series Carton Clamps.

In any communication about the Carton Clamp, refer to the serial number stamped on the nameplate as shown. If the nameplate is missing, the numbers can be found stamped on the back of the baseplate.

**IMPORTANT:** All hoses, tubes and fittings on D-Series Clamps are JIC.

**NOTE:** Specifications are shown in both U.S. and (Metric) units.

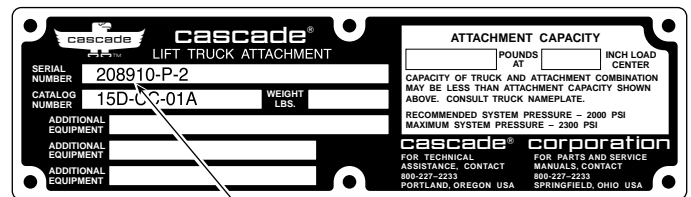
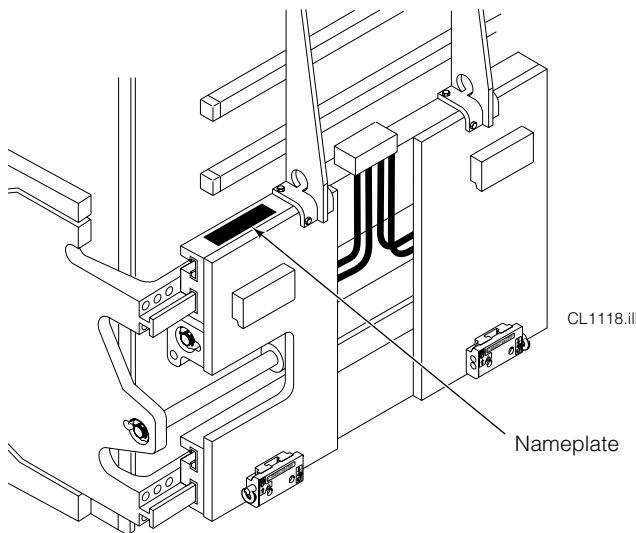

## 1.2 Special Definitions

The statements shown appear throughout this Manual where special emphasis is required. Read all WARNINGS and CAUTIONS before proceeding with any work. Statements labeled IMPORTANT and NOTE are provided as additional information of special significance or to make the job easier.



**WARNING** - A statement preceded by WARNING is information that should be acted upon to prevent **bodily injury**. A WARNING is always inside a ruled box.

**CAUTION** - A statement preceded by CAUTION is information that should be acted upon to prevent machine damage.

**IMPORTANT** - A statement preceded by IMPORTANT is information that possesses special significance.

**NOTE** - A statement preceded by NOTE is information that is handy to know and may make the job easier.

## 2.1

# Truck System Requirements

D-Series Clamps will provide maximum operating capability when the following requirements are met.



**WARNING:** Rated capacity of the truck/attachment combination is a responsibility of the original truck manufacturer and may be less than that shown on the attachment nameplate. Consult the truck nameplate.

### Truck Relief Setting

2000 psi (140 bar) Recommended  
2300 psi (160 bar) Maximum

### Truck Flow Volume <sup>①</sup>

	Min. <sup>②</sup>	Recommended	Max. <sup>③</sup>
<b>15D, 20D, 25D,</b>	4 GPM	7 GPM	7 GPM
<b>35D, 50D, 60D</b>	(15 L/min.)	(26 L/min.)	(26 L/min.)

- ① Cascade D-Series Clamps are compatible with SAE 10W petroleum base hydraulic fluid meeting Mil. Spec. MIL-0-5606 or MIL-0-2104B. Use of synthetic or aqueous base hydraulic fluid is not recommended. If fire resistant hydraulic fluid is required, special seals must be used. Contact Cascade.
- ② Flow less than recommended will result in reduced system performance.
- ③ Flow greater than maximum can result in excessive heating, reduced system performance and reduced hydraulic system life.

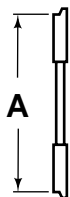

### Carriage Mount Dimension (A) ITA (ISO)

	Minimum	Maximum
<b>Class II</b>	14.96 in. (380.0 mm)	15.00 in. (381.0 mm)
<b>Class III</b>	18.68 in. (474.5 mm)	18.74 in. (476.0 mm)

GA0028.iii

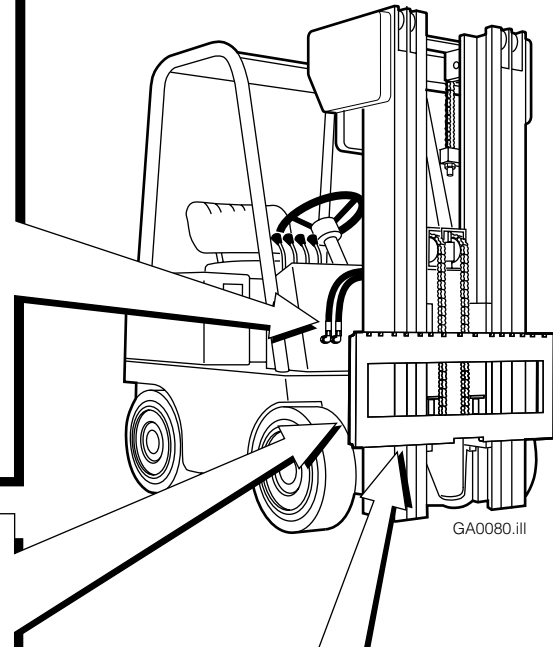

### Carriage

Clean carriage bars and inspect for damaged notches

### Auxiliary Valve Functions

Check for compliance with ITA (ISO) standards:

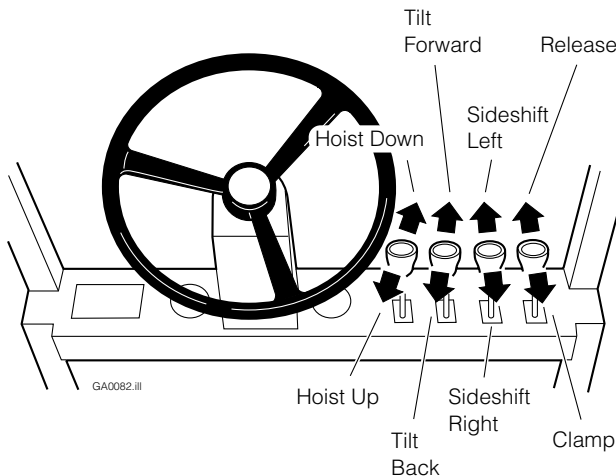

## 2.2 Recommended Hydraulic Supply Options

D-Series Clamps provide the best performance with one of the hydraulic supply arrangements shown below. Refer to *Cascade Hose and Cable Reel Selection Guide*, Part No. 212119, to select the correct hose reel for the mast and truck. The hose and fitting requirements are:

- CLAMP function – No. 8 with a minimum internal diameter of 13/32 in. (10 mm).
- SIDESHIFT function – No. 6 with a minimum internal diameter of 9/32 in. (7 mm).

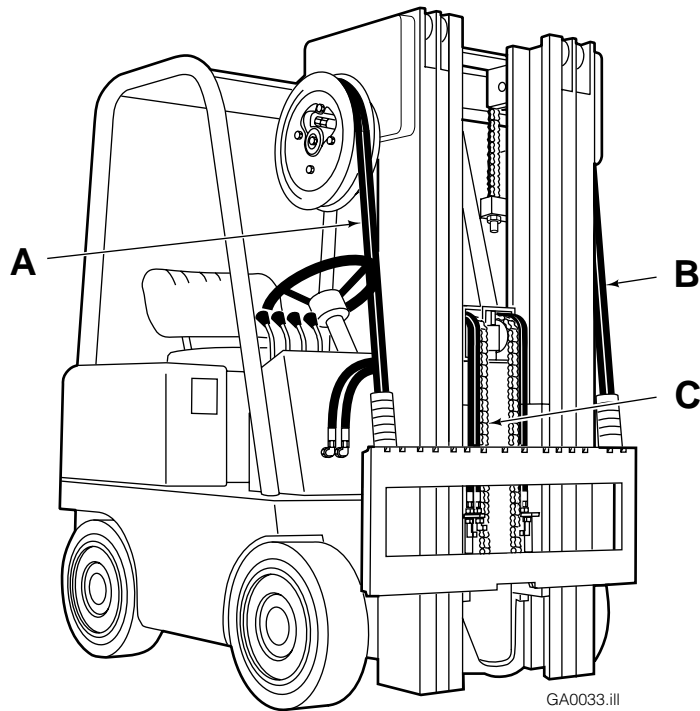

### Sideshifting

#### A and B

RH and LH THINLINE™ 2-port hose reel groups.

#### OR

C Mast double internal hose reeving group.

### Sideshifting with Solenoid

A 6-N-1 cable/hose reel group.

#### OR

#### A and C

Cable reel and single internal hose reeving group.

## 2.3 Installation Procedure

Follow the steps shown to install the Clamp on the truck. Read and understand all **WARNING** and **CAUTION** statements. If you don't understand a procedure, ask your supervisor, or call the nearest Cascade Service Department for assistance.

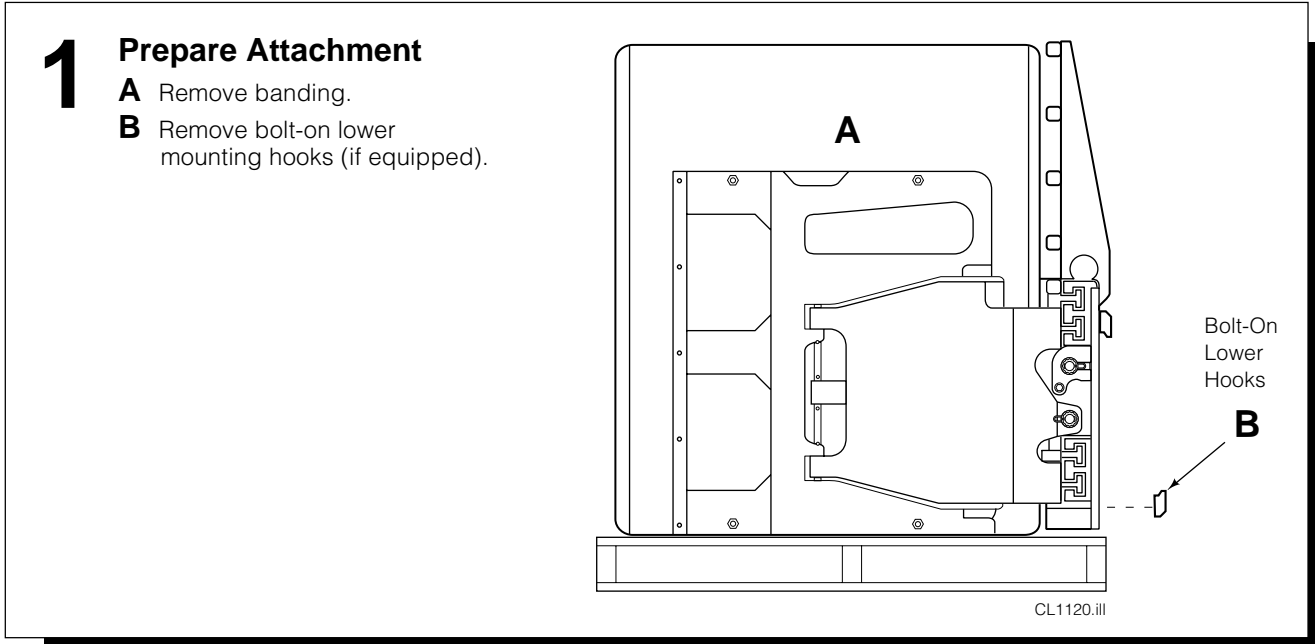

## 2 Unlock Quick-Change lower mounting hooks

- A** Remove pin and drop hooks (new type) or rotate hooks (early type) into unlocked position.
- B** Reinstall pin in lower hole.

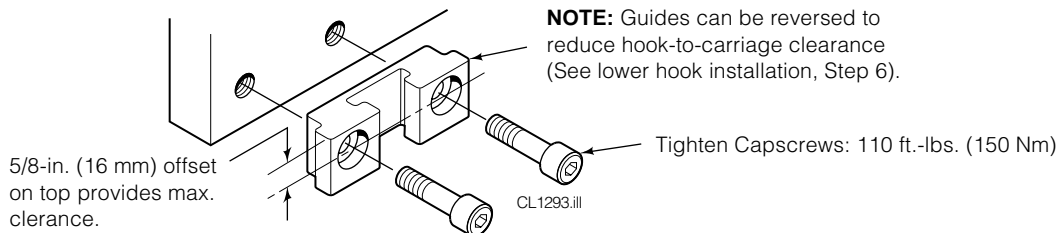
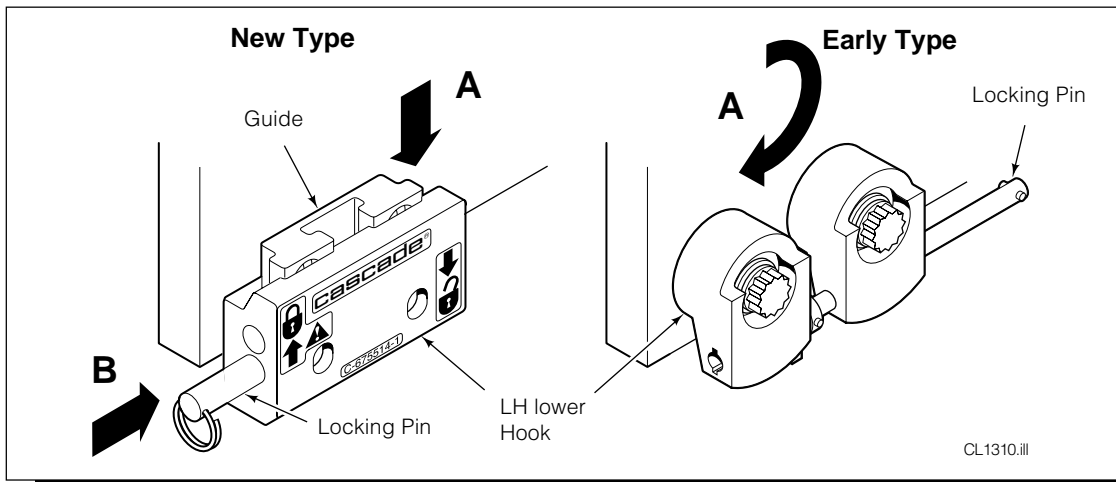

## 3 Prepare Hoses

- A** Determine hose lengths required for hydraulic supply configuration of truck.
- B** Cut hoses to length, install end fittings or Quick-Disconnect coupling kits.

**WARNING:** Do not remove the special fitting from the valve CLAMP (CL) port. Use a 6-8 reducer for No. 6 hose connection.

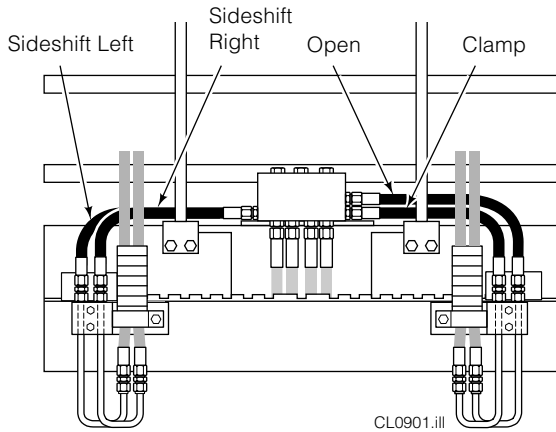

Sideshifting – Double Hose Reels

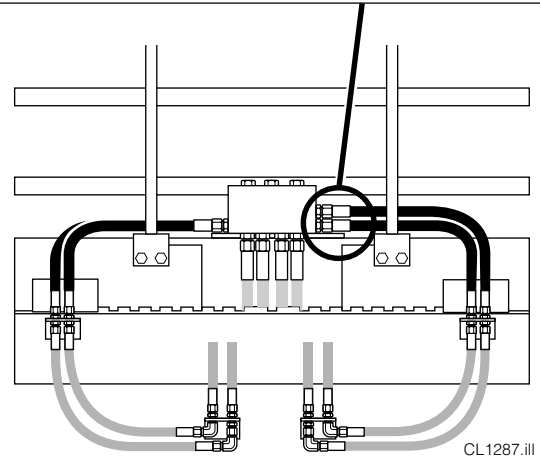

Sideshifting – Double Internal Hose Reeving

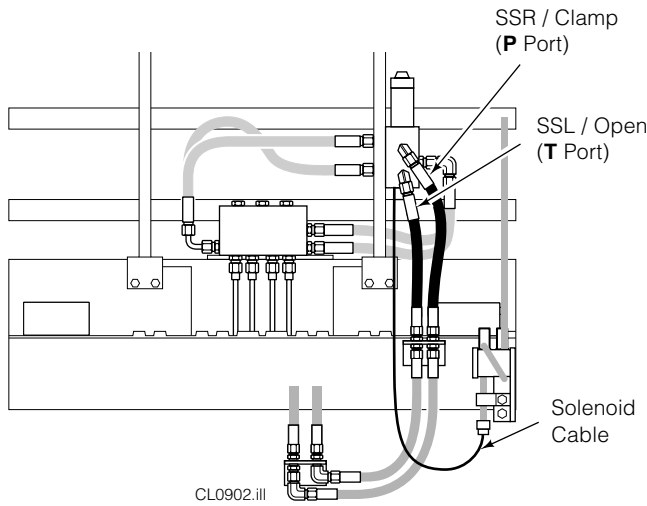

Sideshifting with Solenoid – IHR and Cable Reel

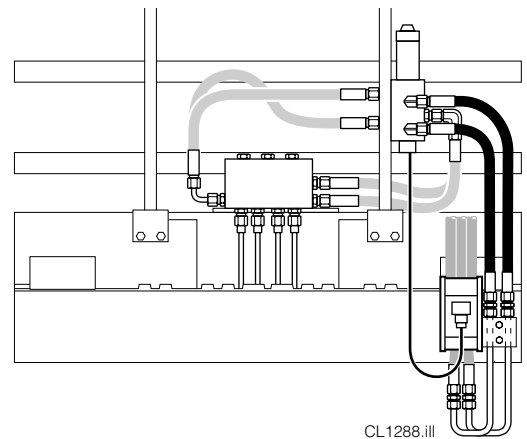

Sideshifting with Solenoid – 6-N-1 Cable/Hose Reel

## 4 Flush hydraulic supply hoses

- A** Install hoses using union fittings.
- B** Operate auxiliary valves for 30 seconds.
- C** Remove union fittings.

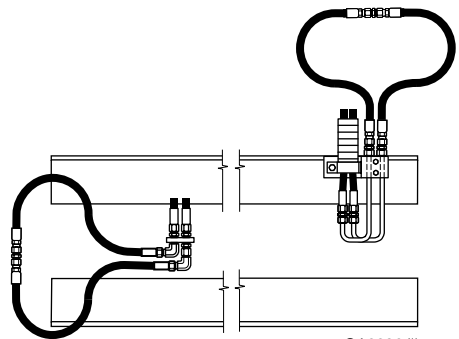

GA0092.iii

## 5 Mount Clamp on truck carriage

- A** Center truck behind Carton Clamp.
- B** Tilt forward and raise carriage into position.
- C** Engage upper mounting hooks with carriage. Make sure tab on left upper hook engages a notch on the top carriage bar.
- D** Lift Clamp 2 in. (5 cm) off pallet.

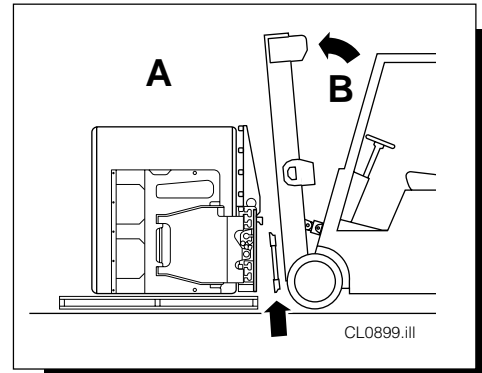

ITA Class II – 0.60–0.66 in. (15–17 mm)  
 ITA Class III – 0.72–0.78 in. (18–20 mm)

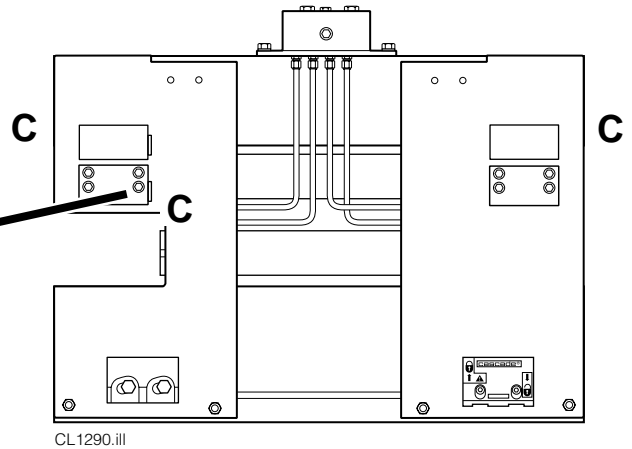
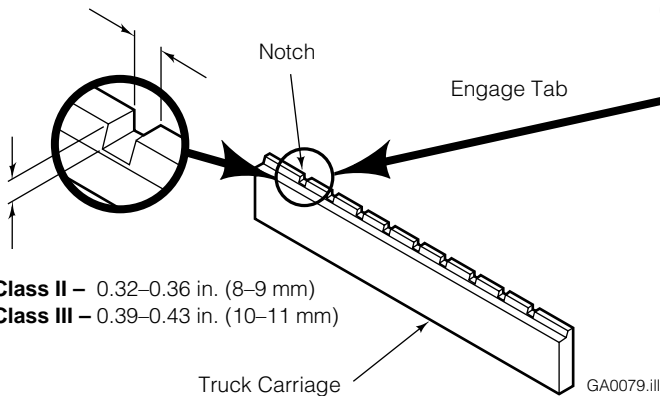

## 6 Install and engage lower hooks

### QUICK-DISCONNECT TYPE

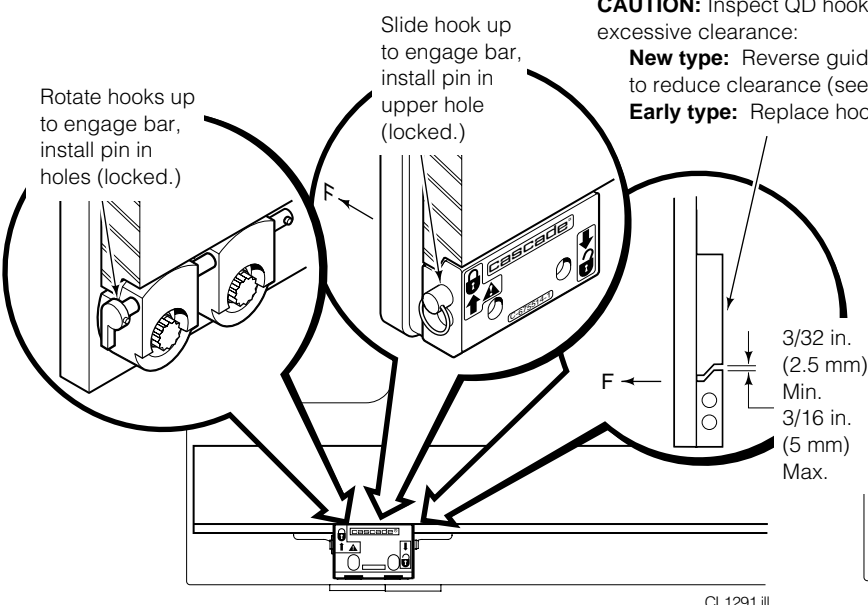

### BOLT-ON TYPE

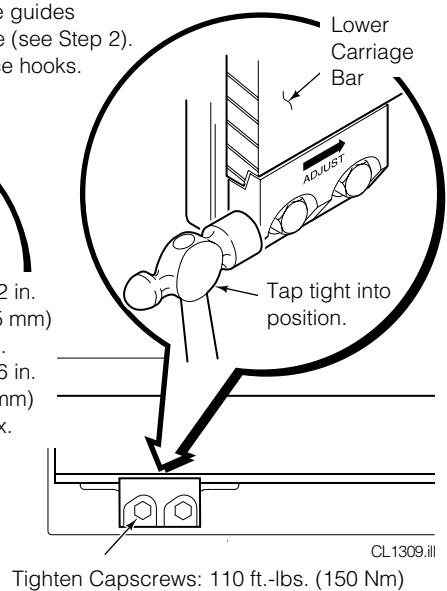

## 7 Connect hoses prepared in Step 3 to Attachment

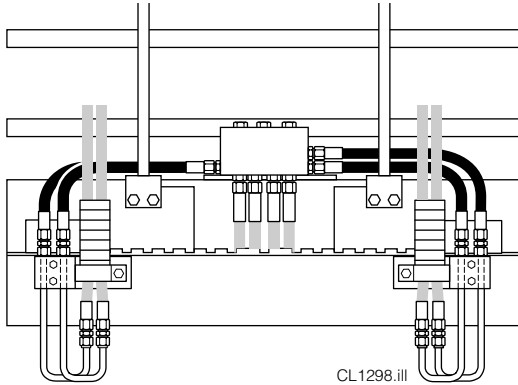

Double Hose Reels Hydraulic Supply

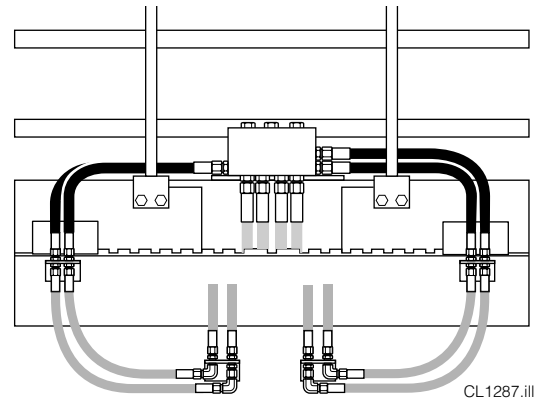

Internal Hose Reaving Hydraulic Supply

## 8 Install solenoid control knob – (Solenoid-equipped units)

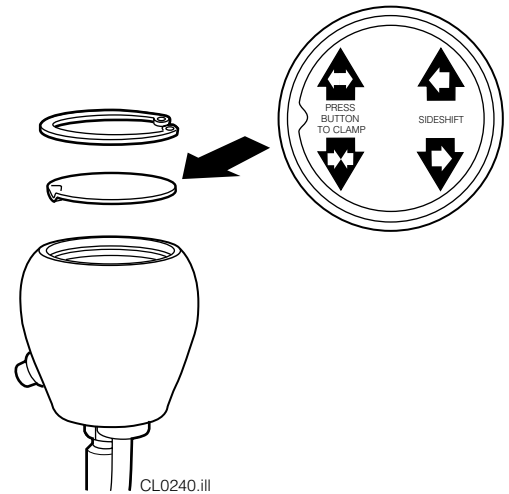
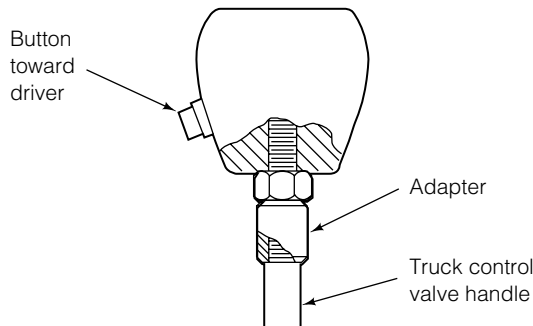

## 9 Install wiring – (Solenoid-equipped units)

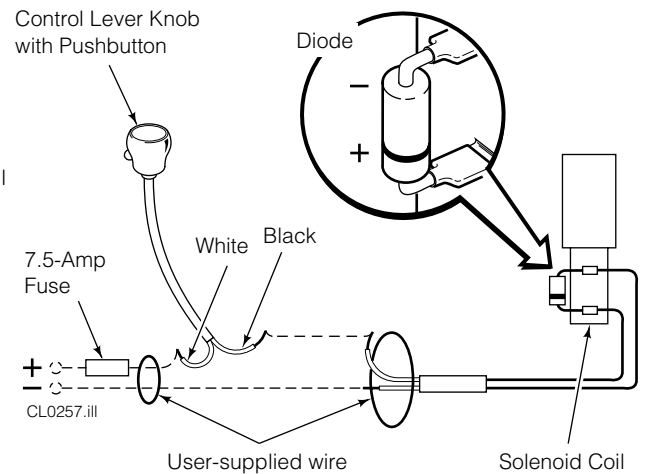
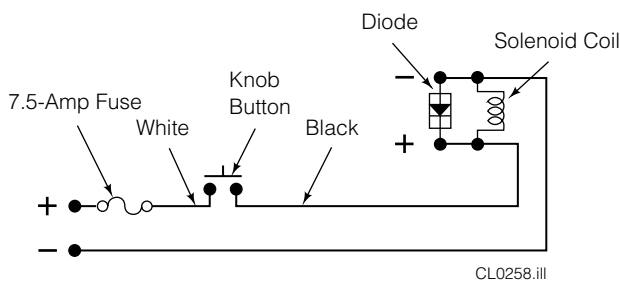

## 10 Cycle Clamp functions

- With no load, cycle each Carton Clamp function several times.
- Check for operation in accordance with ITA (ISO) standards.
- Clamp and lift a maximum load. Sideshift left and right. Check for proper clamp force, equal arm movement and adequate speed.
- Check for leaks at fittings, valve and cylinders.



**WARNING:** Make sure all personnel are clear of the Clamp during testing.

### SIDESHIFTING CLAMPS

- A** Sideshift Left
- B** Sideshift Right
- C** Release Arms
- D** Clamp Arms

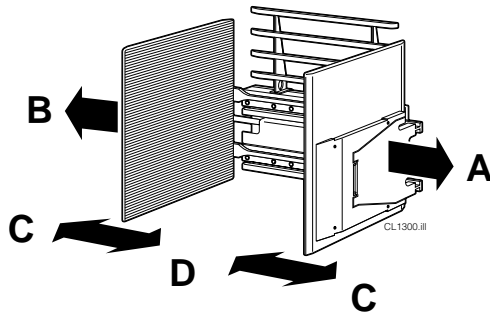

### SIDESHIFTING CLAMPS WITH SOLENOID VALVE

- A** Sideshift Left
- A** Release Arms  
*(press knob button)*
- B** Sideshift Right
- B** Clamp Arms  
*(press knob button)*

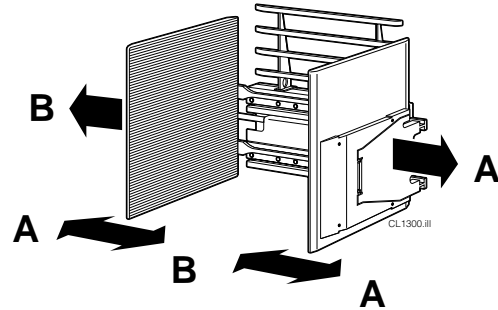

### AUXILIARY VALVE FUNCTIONS

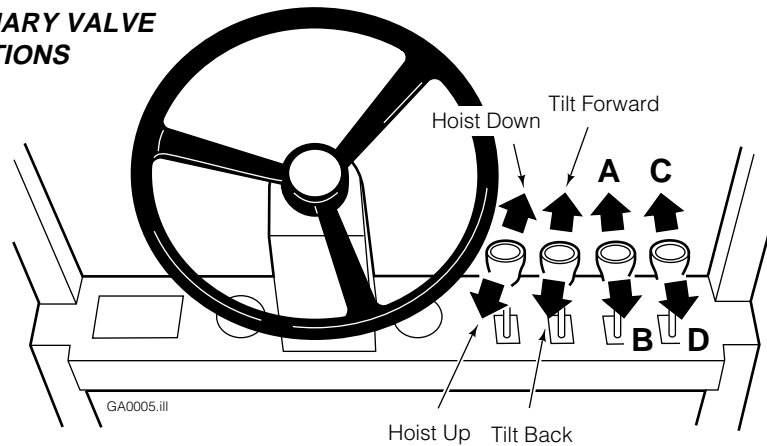

## 3.1 100-Hour Maintenance

Every time the lift truck is serviced or every 100 hours of truck operation, whichever comes first, complete the following maintenance procedures on the Clamp:

- Check for loose or missing bolts, worn or damaged supply hoses and hydraulic leaks.
- Check the cylinder anchor nuts for proper connection and tightness. Lubricate with chassis grease.
- Lubricate the four arm bars (see table).
- Check decals and nameplate for legibility.
- Check contact pads for wear, nicks and distortion.



**WARNING:** After completing any service procedure, always test the Clamp through five complete cycles. First test the Clamp empty, then test with a load to make sure the attachment is operating correctly before returning to the job.

Application	Recommended Lubrication
General Products	Chassis Grease w/Moly
Food Industry	Chassis Grease (DuBois FGG-2)
Dry Lube Conditions	Slip Plate No. 3 (Superior Graphite)

## 3.2 500-Hour Maintenance

After each 500 hours of truck operation, in addition to the 100-hour maintenance, perform the following procedures:

- Check the lower mounting hook engagement clearance with the truck carriage bar:

**Quick-Change Hooks** – 3/32 in. (2.5 mm) min.  
3/16 in. (5 mm) max.

**Bolt-On Hooks** – Tight against lower carriage bar.

If adjustment is necessary, refer to Installation Step 6. Tighten lower hook capscrews to 110 ft.-lbs. (150 Nm).

- Check clamp force. Cascade Clamp Force Indicators (200645, 680072 or 830141) are available for this test.

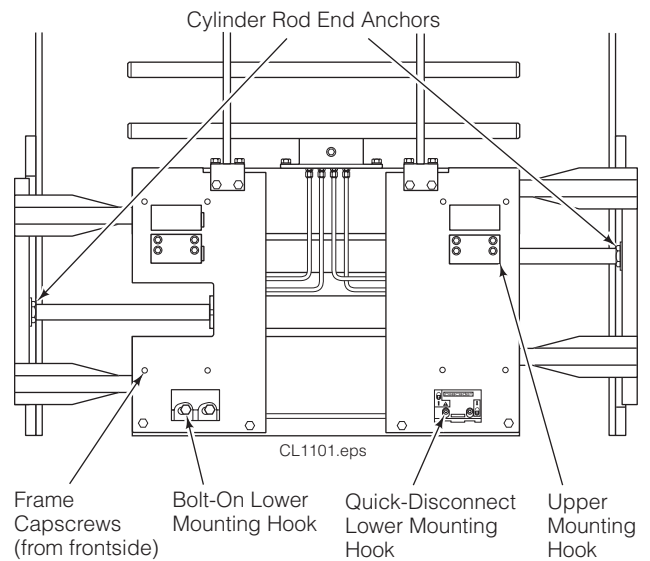

Back (Driver's) View

## 3.3 1000-Hour Maintenance

After each 1000 hours of truck operation, in addition to the 100 and 500-hour maintenance, perform the following procedures:

- Inspect arm bearings for wear. If any bearing is worn to less than .040 in. (1 mm) thickness, replace all bearings. Refer to Section 5.2-7.
- Tighten contact pad mounting bolts to 50 ft.-lbs. (65 Nm).
- Inspect and replace wear tiles if worn. Refer to Section 5.2-5.
- Inspect pad pivot pins and bushings. Replace is worn. Refer to Section 5.2-3 or 5.2-4.

## 3.4 2000-Hour Maintenance

After each 2000 hours of truck operation, in addition to the 100, 500 and 1000-hour maintenance, perform the following procedures:

- Inspect arm bearings for wear. If any bearing is worn to less than .040 in. (1 mm) thickness, replace all bearings. Refer to Section 5.2-7.
- Tighten frame capscrews to 75 ft.-lbs. (100 Nm).

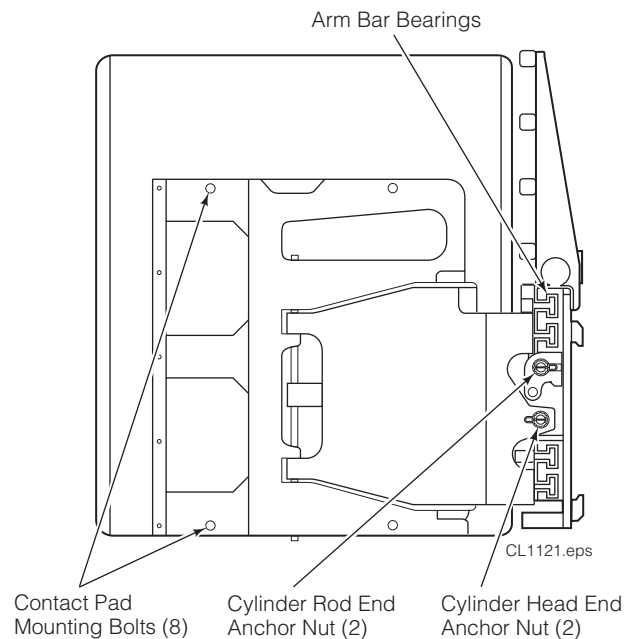

Left Side

## 4.1 General Procedures

### 4.1-1 Truck System Requirements

- Truck hydraulic pressure should be within the range shown in Specifications, Section 6.1. **PRESSURE TO THE CLAMP MUST NOT EXCEED 2300 psi (160 bar).**
- Truck hydraulic flow should be within the range shown in Specifications, Section 6.1.
- Hydraulic fluid supplied to the Clamp must meet the requirements shown in Specifications, Section 6.1.



**WARNING:** Before servicing any hydraulic component, relieve pressure in the Attachment system. Turn the truck off and move the truck auxiliary control lever several times in both directions.

After completing any service procedure, always test the Clamp through several cycles. First test the Clamp empty to bleed any air trapped in the system to the truck tank. Then test the Clamp with a load to be sure it operates correctly before returning to the job.

Stay clear of the load while testing. Do not raise the load more than 4 in. (10 cm) off the floor while testing.

### 4.1-2 Tools Required

In addition to a normal selection of hand tools, the following are required:

- 20 GPM (75 L/min) inline flow meter. (Cascade Flow Meter Kit, part no. 671477.)
- 3000 psi (200 bar) pressure gauge. (Cascade Pressure Gauge Kit, part no. 671212.)
- Assorted fittings, lines, drain hoses and quick-couplers as required.

#### Flow Meter Kit 671477

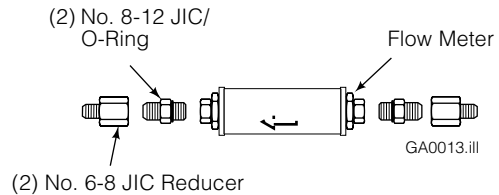

#### Pressure Gauge Kit 671212

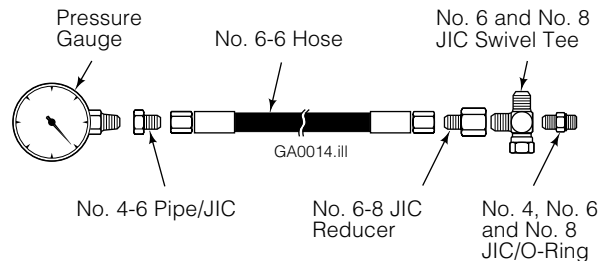

#### Diagnostic Quick-Disconnects

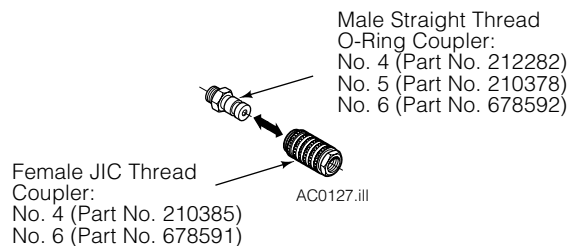

**NOTE:** Diagnostics Kit 394382 includes all of the above.

## 4.1-3 Troubleshooting Chart

**Determine All The Facts** – It is important to gather all the facts about the problem before beginning any service procedures. The first step is to talk to the equipment operator. Ask for a complete description of the malfunction. Guidelines below and on the following pages can then be used as a starting point to begin troubleshooting.

### Clamp Circuit

- Clamp drops load after it has been picked up.
- Clamp will not carry load up to its rated capacity.
- Clamp arms have uneven travel.
- Clamp arms travel slowly.
- Clamp arms will not move.

To correct these problems, see Sections 4.3.

**NOTE:** Some Clamps have a regenerative hydraulic circuit that causes the arms to open at a faster speed than when closing. This is a normal Clamp function.

### Sideshift Circuit

- Clamp drops load while sideshifting.
- Clamp drops load at end of sideshift stroke.
- Clamp sideshifts left and right at different speeds.
- Clamp will not sideshift.

To correct these problems, see Sections 4.4.

### Carton Clamp Loads

- Front stack of load tilts out.
- Lower tier of load bridges down or slides out.
- Lower tier of load is creased.

To correct these problems, see Section 4.1-4.

## 4.1-4 Carton Clamp Loads

**IMPORTANT:** Before adjusting contact pad camber to solve handling problems, make sure the Clamp is being used correctly and is not damaged. Use the Troubleshooting procedure shown and, if necessary, adjust the contact pad camber using a Cascade Shim Service Kit.

**IF FRONT STACK OF LOAD TILTS OUT:**

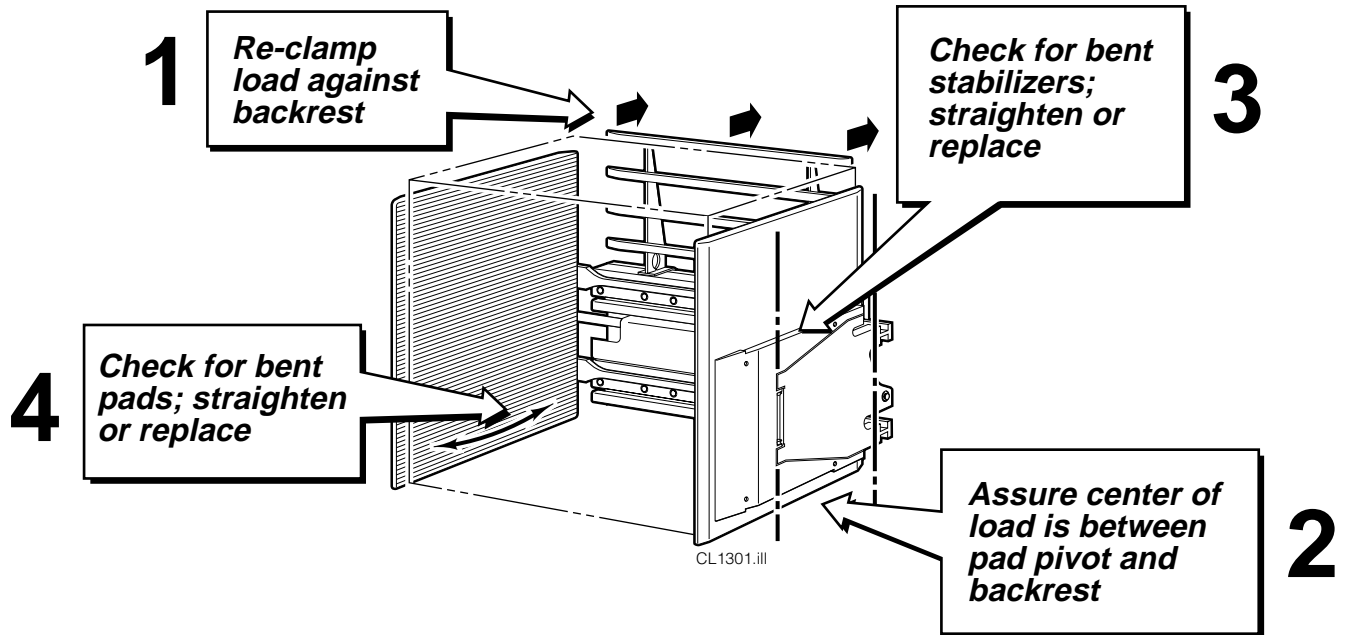

**IF LOWER TIER OF LOAD BRIDGES DOWN OR SLIDES OUT:**

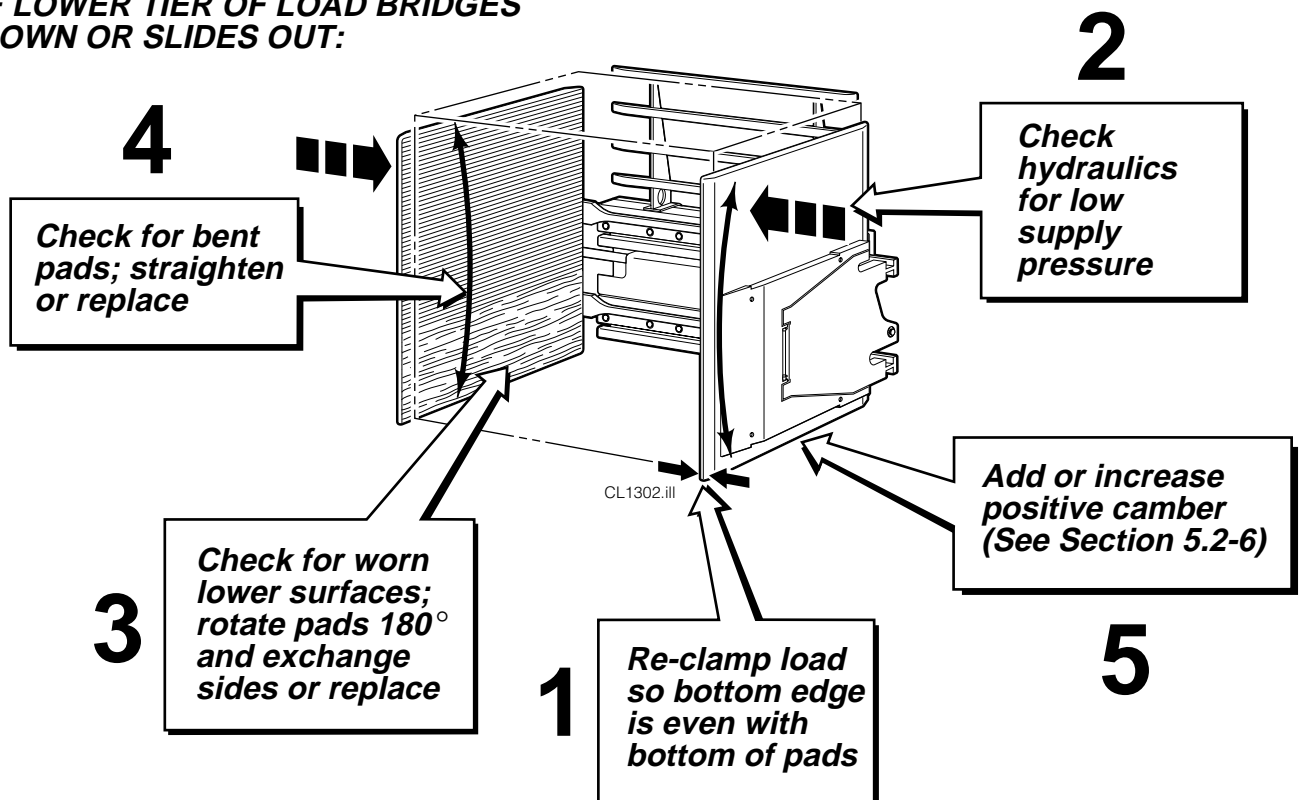

## 4.1-4 Carton Clamp Loads (Continued)

**IF LOWER TIER OF LOAD IS CREASED:**

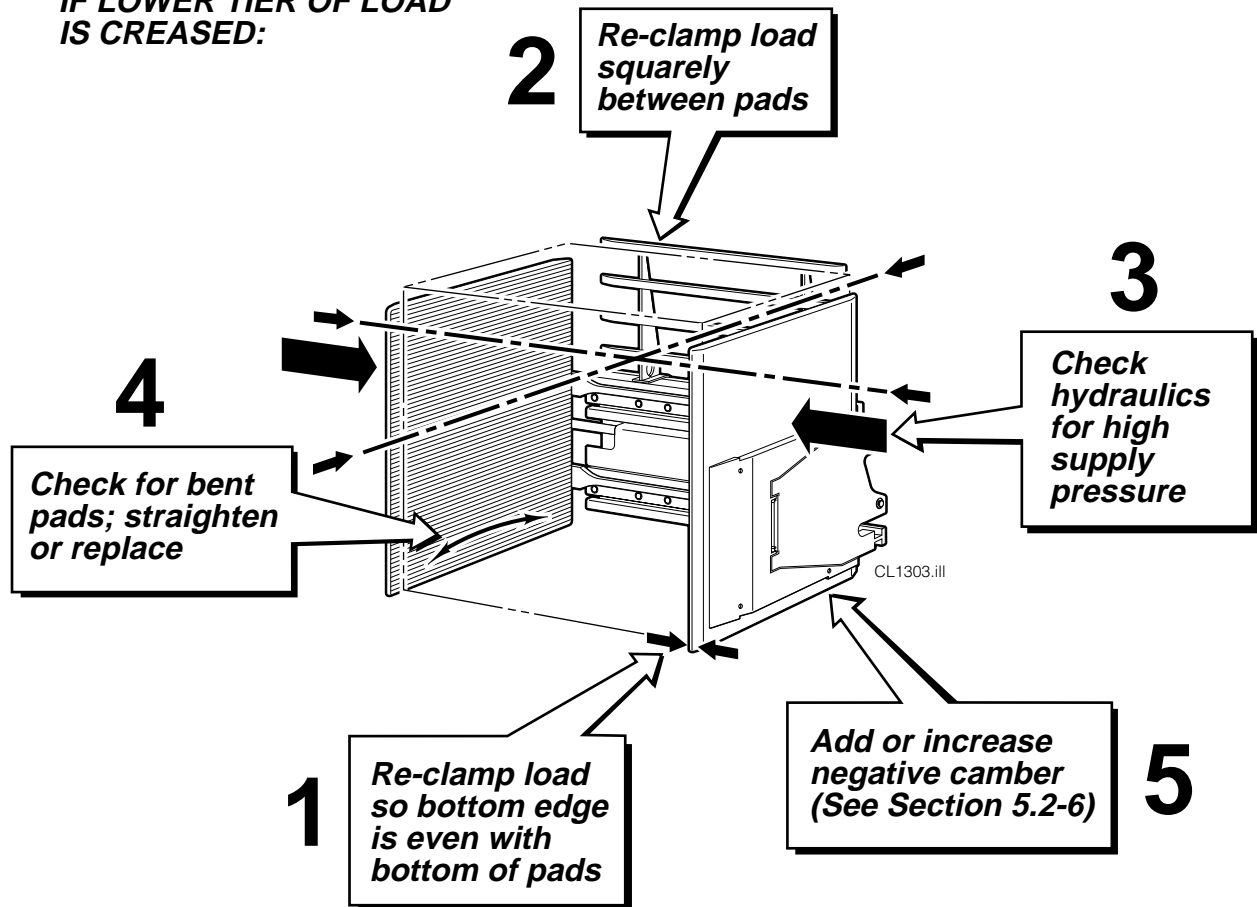

**TYPICAL PAD CAMBER FOR HANDLING CARTON CASE LOADS**

		Front View – Pads
CANNED / BOTTLED / DENSE CASE GOODS	Neutral-to-Positive	
SOFT CASE GOODS	Neutral-to-Negative	
APPLIANCE / LARGE CASE GOODS	Neutral-to-Negative	
UNKNOWN LOADS	Start with neutral, look for creases and adjust camber as required.	

CL0093.iii





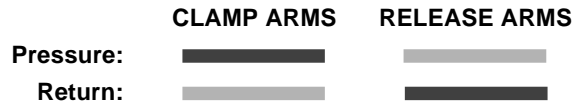
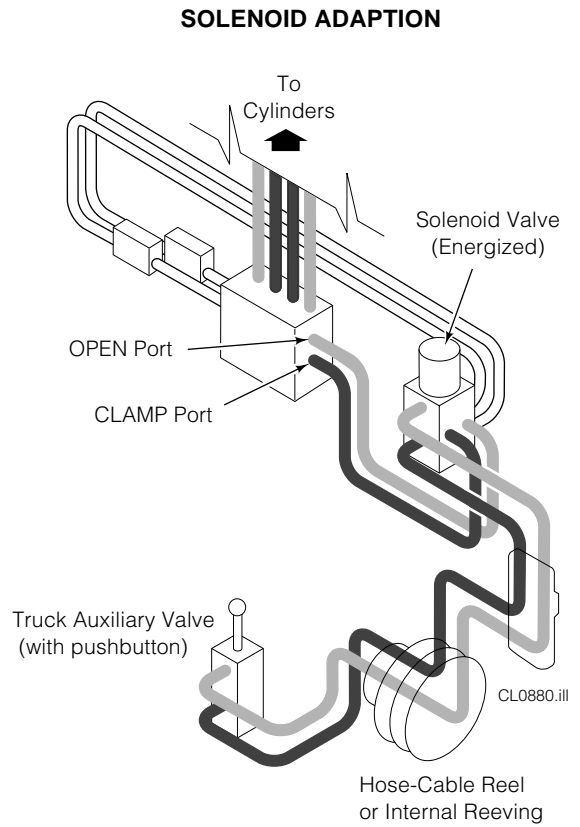
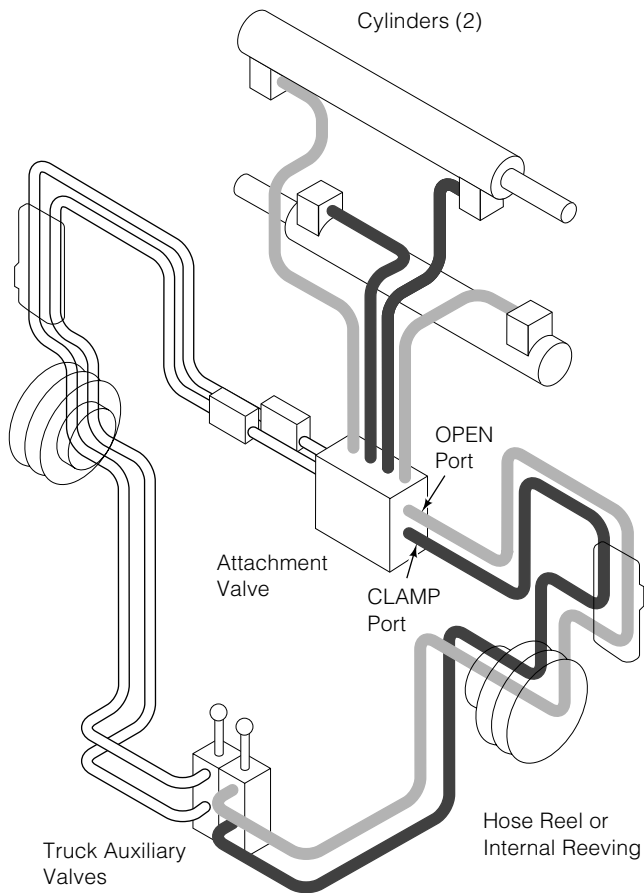

## 4.2 Plumbing

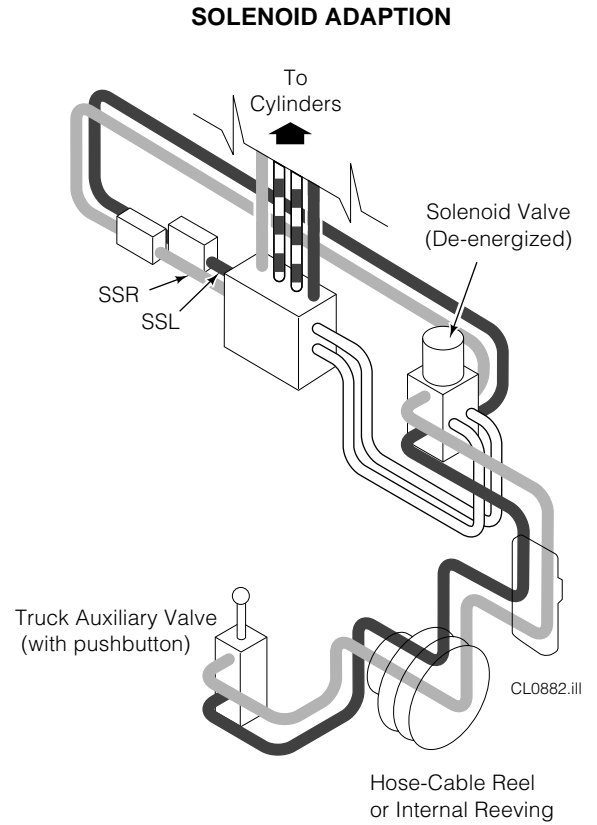
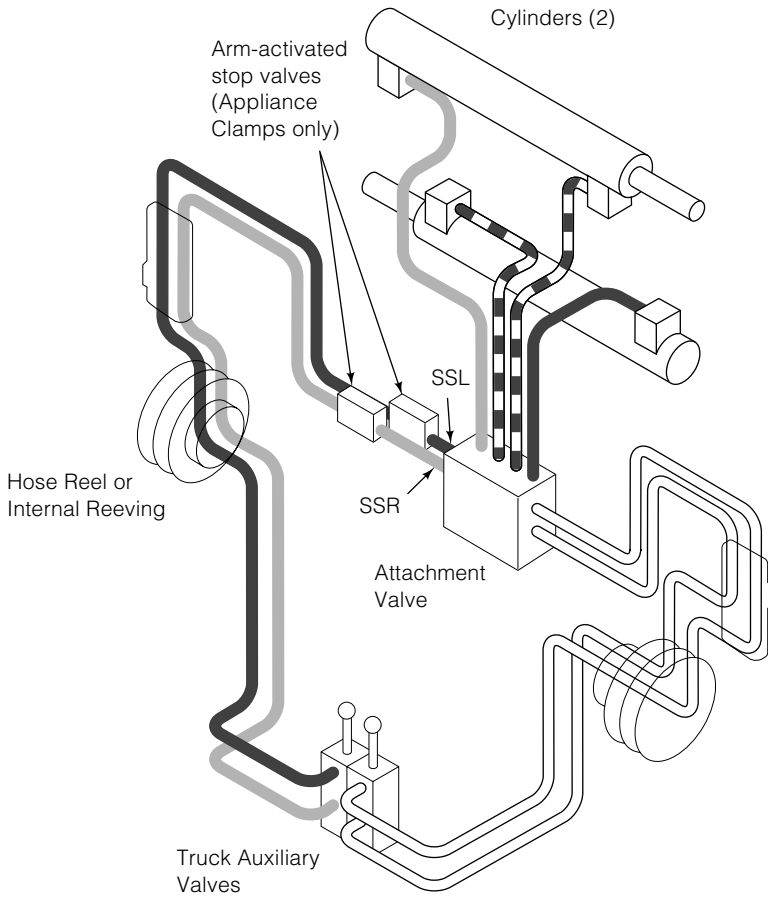
### 4.2-1 Hosing Diagram, Clamp Circuit



## 4.2-2 Hosing Diagram, Sideshift Circuit



	<b>SIDESHIFT LEFT</b>	<b>SIDESHIFT RIGHT</b>
<b>Pressure:</b>		
<b>Return:</b>		
<b>Slave:</b>		

## 4.2-3 Hydraulic Circuit

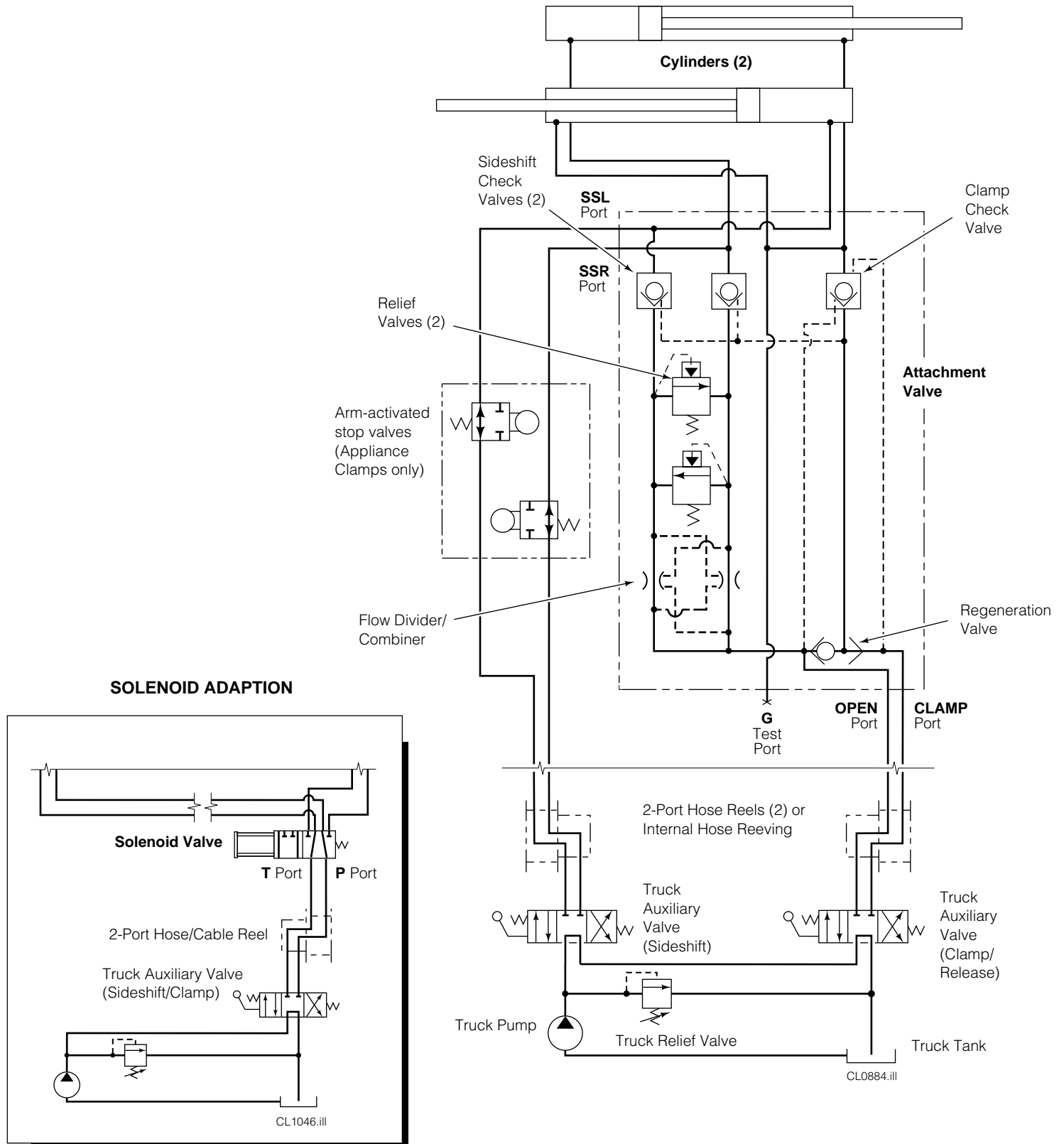

## 4.3 Clamp Function

There are five potential problems that could affect the CLAMP function:

- Incorrect load handling. Refer to the *Operator's Guide* for suggested procedures.
- Incorrect hydraulic pressure or flow from the lift truck.
- External leaks.
- Defective solenoid coil or valve (if equipped).
- Worn/defective cartridge valves or cylinder seals.

### 4.3-1 Supply Circuit Test

- 1 Check the pressure supplied by the truck at the carriage hose terminal. Pressure must be within the range shown in Specifications, Section 6.1. **PRESSURE TO THE CLAMP MUST NOT EXCEED 2300 PSI (160 bar).**
- 2 Check the flow volume at the carriage hose terminal. Flow must be within the range shown in Specifications, Section 6.1.
- 3 Close the arms fully, holding the lever in the CLAMP position for a few seconds. Release the lever and check for external leaks at fittings, hoses, valve and manifold.

### 4.3-2 Clamp Circuit Pressure Test

- 1 Press the solenoid button (if equipped) and listen for a 'click' at the solenoid valve. If no sound is heard, first check the fuse, wiring and coil (see Section 4.5). Assure that the valve is not jammed (see Section 5.6).
 

**IMPORTANT:** Solenoid-operated valves must be plumbed so that the solenoid is **energized** during the CLAMP/RELEASE function.
- 2 Position the arms to mid-stroke. Turn the truck off and connect a 3000 psi (200 bar) pressure gauge to the 'G' test port on top of the main valve.
 

**IMPORTANT:** Before installing pressure gauge, move the CLAMP lever momentarily to relieve pressure trapped by the system check valves.
- 3 Start the truck and close the arms fully, holding the lever in the CLAMP position for a few seconds.
- 4 Release the lever and watch the pressure gauge:
  - If the pressure drop **is less** than 150 psi (10 bar) initially, and additional drop does not exceed 25 psi (1.7 bar) per minute, the problem is not hydraulic (see Section 4.3).
  - If the pressure drop **is more** than 150 psi (10 bar) initially, and additional drop exceeds 25 psi (1.7 bar) per minute, Turn the truck off and proceed to the valve test.



**WARNING:** Before removing hydraulic lines or components, relieve pressure in the Attachment hydraulic system. Turn the truck off and move the auxiliary control lever several times in both directions.

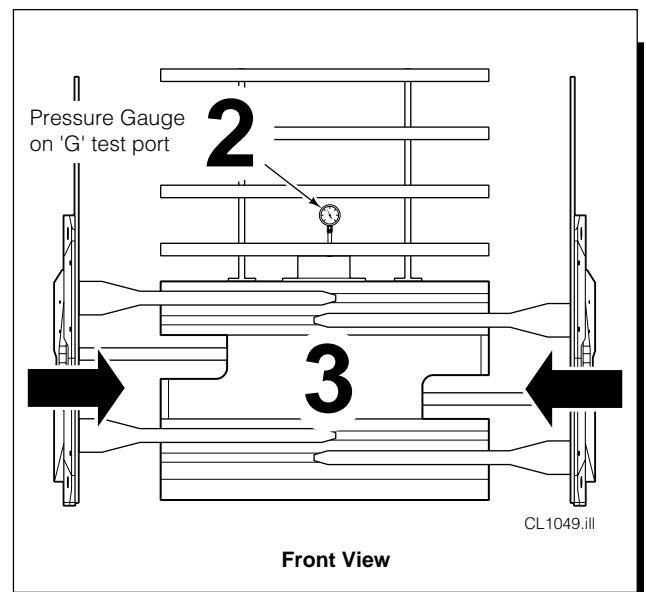
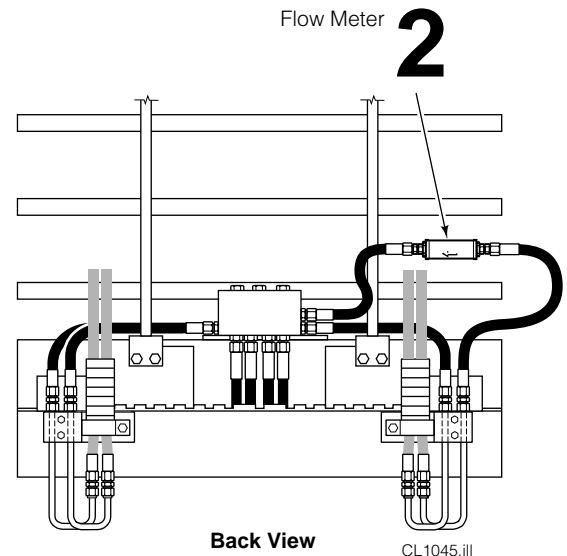

## 4.3-3 Valve Test

- 1 Remove the bumper (see Section 5.4-1, Step 2).
- 2 Disconnect the hydraulic supply lines at the rod ends of both cylinders. Cap the ports and plug the lines.
- 3 Start the truck and hold the lever in the CLAMP position for a few seconds.
- 4 Release the lever and watch the pressure gauge:
  - If the pressure drop **is more** than 150 psi (10 bar) initially, and additional drop exceeds 25 psi (1.7 bar) per minute, the valve is faulty and requires service (see Section 5.3.)
  - If the pressure drop **is less** than 150 psi (10 bar) initially, and additional drop does not exceed 25 psi (1.7 bar) per minute, one or both cylinders require service. Turn the truck off and proceed to the cylinder test.

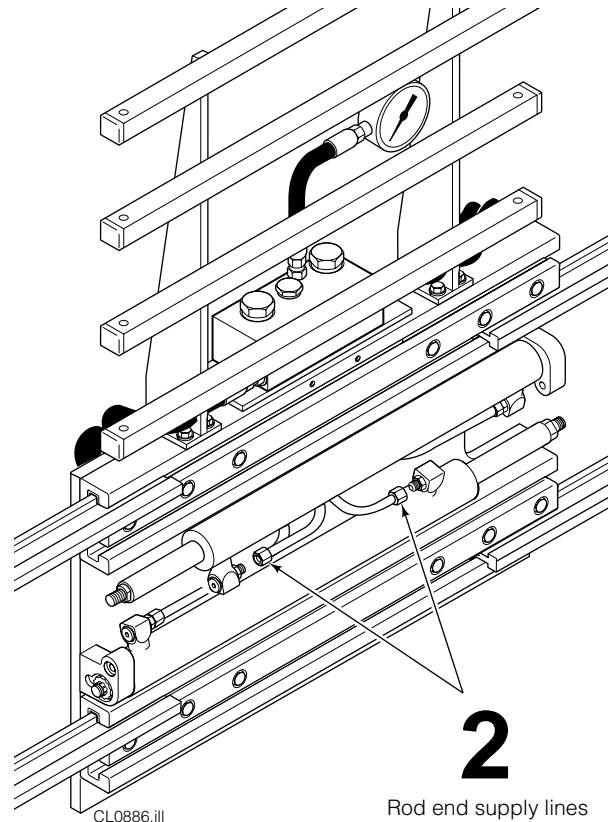

2  
Rod end supply lines  
(plug lines and cap ports)

## 4.3-4 Cylinder Test

- 1 Connect one of the rod end hydraulic lines to its cylinder.  
**IMPORTANT:** The line to the other cylinder and its port must remain plugged.
- 2 Start the truck and hold the lever in the CLAMP position for a few seconds.
- 3 Release the lever and watch the pressure gauge:
  - If the pressure drop **is more** than 150 psi (10 bar) initially, and additional drop exceeds 25 psi (1.7 bar) per minute, the cylinder connected to the valve is faulty and requires service (see Section 5.3).
  - If the pressure drop **is less** than 150 psi (10 bar) initially, and additional drop does not exceed 25 psi (1.7 bar) per minute, the other cylinder is faulty and requires service (see Section 5.4).

It is recommended that a similar pressure test be performed on the other cylinder before servicing.

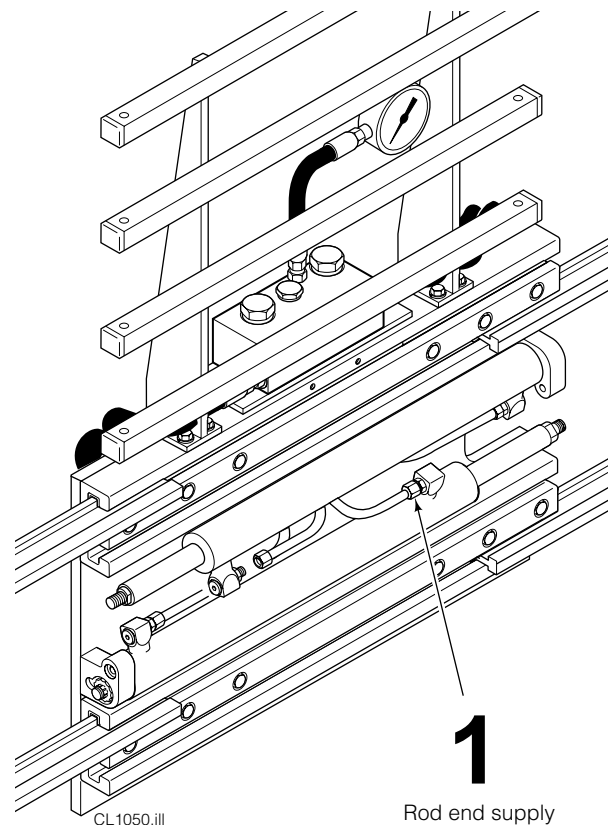

1  
Rod end supply  
line connected to  
one (1) cylinder

## 4.4 Sideshift Function

There are five potential problems that could affect the sideshift function:

- Incorrect load handling. Refer to the *Operator's Guide* for suggested procedures.
- Incorrect hydraulic pressure or flow from the lift truck.
- External leaks.
- Defective solenoid coil or valve (if equipped).
- Worn/defective valve, cartridges, or cylinder seals.

### 4.4-1 Supply Circuit Test

- 1 Check the pressure supplied by the truck at the carriage hose terminal. Pressure must be within the range shown in Specifications, Section 6.1. **PRESSURE TO THE CLAMP MUST NOT EXCEED 2300 PSI (160 bar).**
- 2 Check the flow volume at the carriage hose terminal. Flow must be within the range shown in Specifications, Section 6.1.
- 3 Sideshift left or right fully, holding the lever in the SIDESHIFT position for a few seconds. Release the lever and check for external leaks at fittings, hoses, valve and manifold.

### 4.4-2 Sideshift Circuit Test

- 1 Press the solenoid button (if equipped) and listen for a 'click' at the solenoid valve. If no sound is heard, first check the fuse, wiring and coil (see Section 4.5). Assure that the valve is not jammed (see Section 5.6).
 

**IMPORTANT:** Solenoid-operated valves must be plumbed so that the solenoid is **not energized** during the SIDESHIFT function.
- 2 Position the arms to mid-stroke. Turn the truck off and connect a 3000 psi (200 bar) pressure gauge to the 'G' gauge port on the main valve.
- 3 With a maximum load, sideshift left and hold the lever for a few seconds.
- 4 Release the lever and watch the pressure gauge:
  - If the pressure drop **is more** than 150 psi (10 bar) initially, and additional drop exceeds 25 psi (2 bar) per minute, the SIDESHIFT LEFT check valve may be faulty. Replace the cartridge.
  - If the pressure drop **is less** than above, sideshift right and hold the lever for a few seconds.
- 5 Release the lever and watch the pressure gauge:
  - If the pressure drop **is more** than 150 psi (10 bar) initially, and additional drop exceeds 25 psi (2 bar) per minute, the SIDESHIFT RIGHT check valve may be faulty. Replace the cartridge.
  - If the pressure drop **is less** than 150 psi (10 bar) initially, and additional drop does not exceed 25 psi (1.7 bar) per minute, the problem is not hydraulic (see Section 4.4).



**WARNING:** Before removing hydraulic lines or components, relieve pressure in the Attachment hydraulic system. Turn the truck off and move the auxiliary control valve lever several times in both directions.

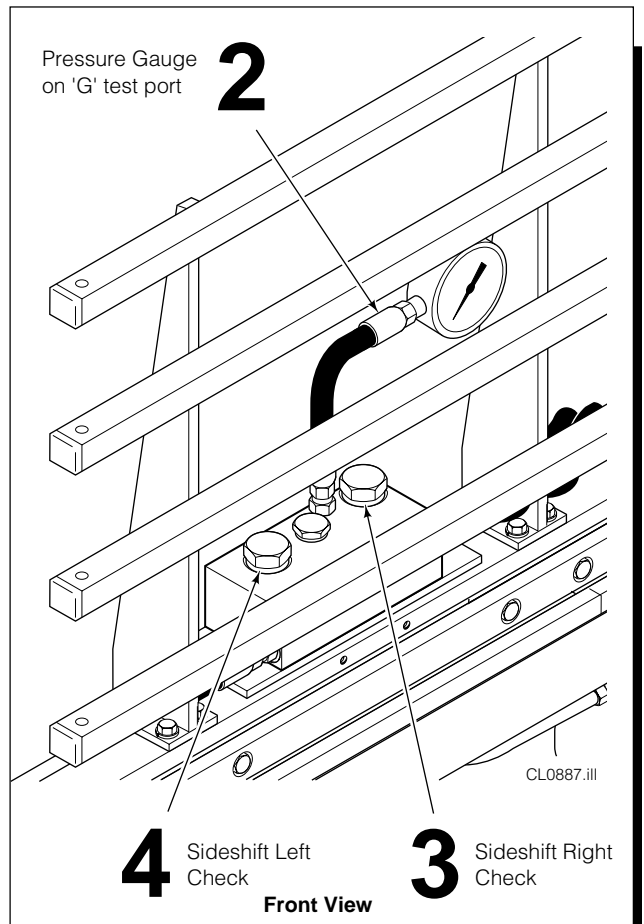
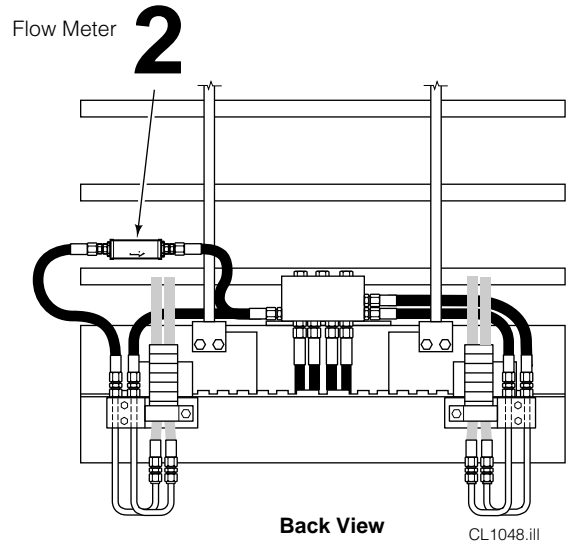

## 4.5

### Electrical Circuit (Solenoid-equipped Clamps)

Use the electrical schematic and diagram shown and follow the steps below:

- 1 Check the control knob circuit fuse. Replace if necessary.
- 2 Check for loose electrical connections at the truck ignition switch, control knob button, solenoid coil terminals and diode.
- 3 Remove the diode from the solenoid coil terminal. Test with an ohmmeter for high resistance in one direction and no resistance in the other direction. If there is no resistance in both directions, replace the diode.
 

**NOTE:** When replacing the diode, the banded (+) end must be connected to the coil and wiring as shown.
- 4 Disconnect the electrical leads from the solenoid coil terminals. Use a voltmeter to determine if voltage is present at the electrical leads when the button is depressed.
  - If there is **no current** to the solenoid, troubleshoot the electrical circuit for shorts.
  - If there is **current** to the solenoid, test for coil continuity.
- 5 Test for coil continuity by placing an ohmmeter test lead on each solenoid coil terminal (ohmmeter on Rx1 scale).
  - If there is an ohmmeter reading, the coil is good.
  - If the coil is good, but the solenoid does not 'click' when the control knob button is depressed, the solenoid cartridge may be jammed. Refer to Section 5.6.
  - If there is no ohmmeter reading, the coil is defective and should be replaced. Refer to Section 5.6.

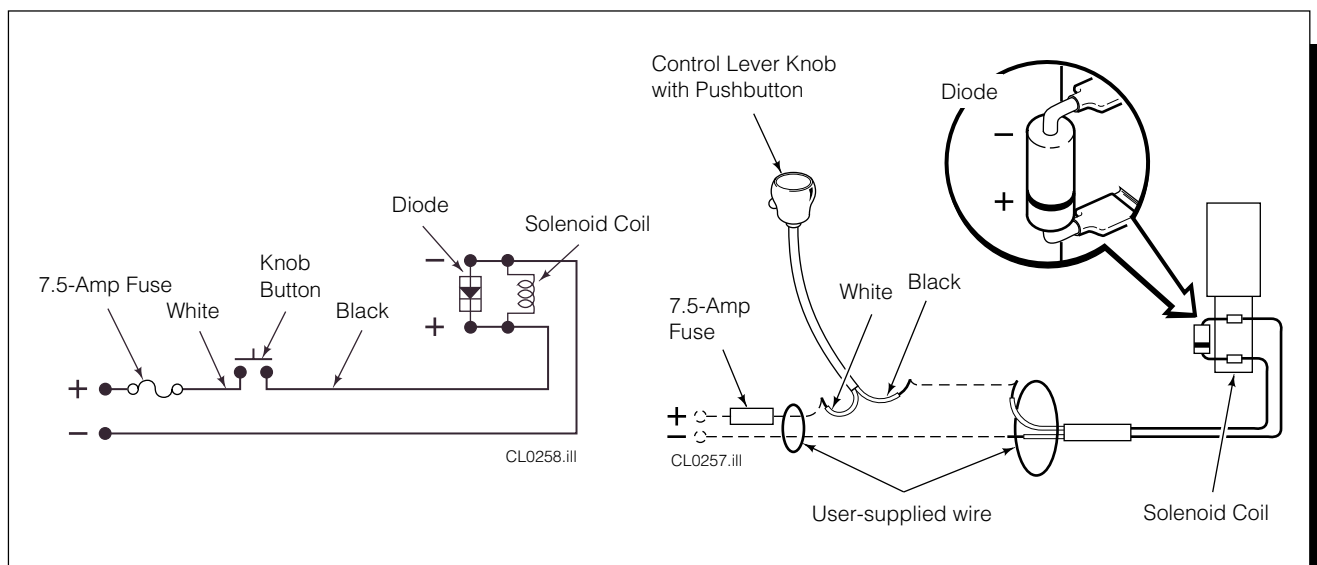

## 5.1 Clamp Removal

1 Position the Clamp's arms to the width of the frame.



**WARNING:** Before removing hydraulic lines or hoses, relieve pressure in the Attachment hydraulic system. Turn the truck off and move the auxiliary control lever several times in both directions.

2 Disconnect and plug the hydraulic supply hoses to the Clamp. Tag hoses for reassembly.

3 Disconnect the lower hooks:

**Quick-Change Hooks** – Remove the locking pins and drop the hooks (new type) or rotate hooks (early type) into the unlocked position. Replace the pins in the lower holes. For reassembly, remove the pins and slide the hooks up (new type) or rotate hooks (early type) to the locked position. Replace the pins in the top holes.

**Bolt-On Hooks** – Remove the capscrews and mounting hooks. For reassembly, tap hooks tight against carriage bar and tighten the capscrews to 110 ft.-lbs. (150 Nm).

4 Lower the Clamp onto a pallet. Tilt the mast forward and lower the carriage to disengage the upper hooks.

5 For Clamp installation, reverse the above procedures except as follows:

- Refer to Section 2.3 for complete installation procedure.

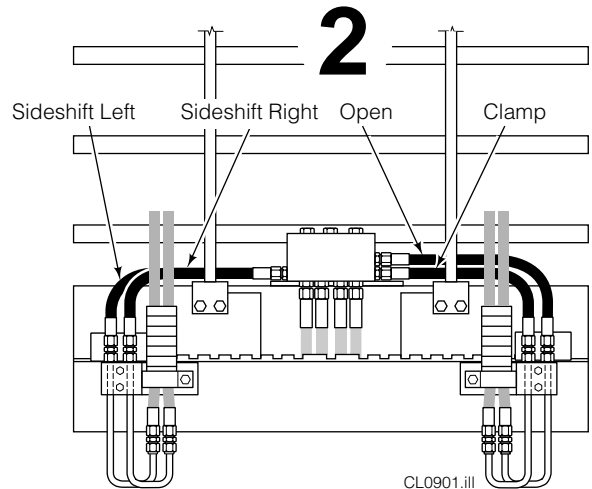

CL0901.iii

Back (driver's) View

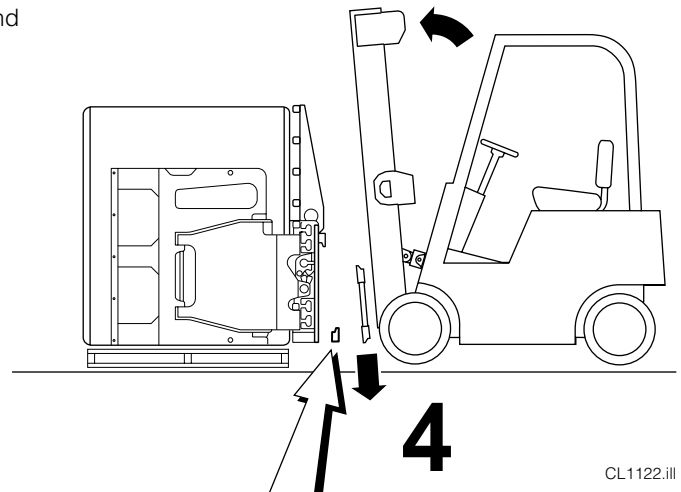

CL1122.iii

### 3

#### QUICK-DISCONNECT LOWER HOOKS

(New Type)

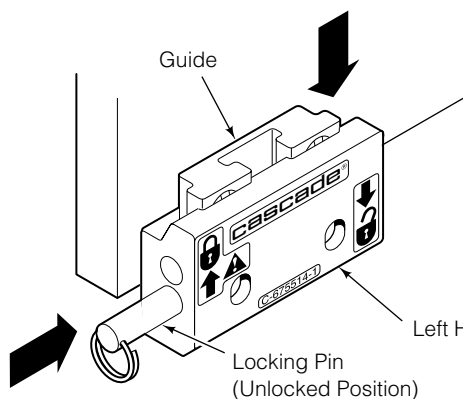

(Early Type)

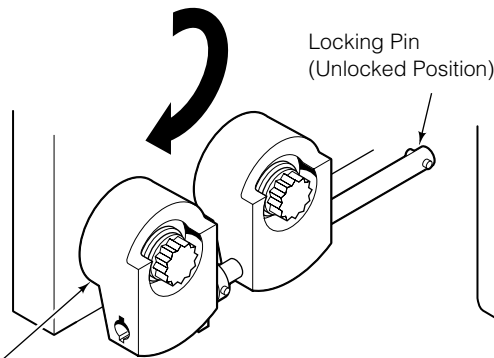

CL1292.iii

#### BOLT-ON LOWER HOOKS

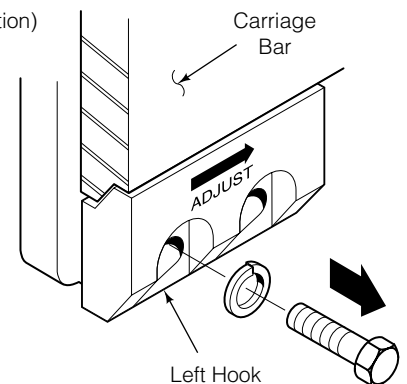

## 5.2 Arms

### 5.2-1 Arm Assemblies – Removal and Installation

The following procedures can be performed with the Clamp mounted on the truck.

- 1 Position the arms to frame width. Lower the Clamp to position the contact pads 1/2 in. (13 mm) above the floor.
- 2 Remove the cylinder rod end joint assembly. For reassembly, assemble the parts as shown and secure with a new cotter pin. Tighten the rod end nut to 160 ft.-lbs. (220 Nm). **NOTE:** Rod end nut tightens against hex washer, providing a loose operating clearance for the anchor joint. Lubricate with chassis grease.
- 3 Attach an overhead hoist and chains to the arm assembly. Position the chain clear of the arm bearing surfaces. **CAUTION:** If removing arm with contact pad, use a lift eyebolt on the contact pad to stabilize the assembly.
- 4 Retract the cylinder rod until it disengages from the arm.



**WARNING:** Keep hands and feet out from under the contact pads and arms.

- 5 Slide the arm assembly out of the frame. Do not damage the bearings when removing the arm.
- 6 For reassembly, reverse the above procedures with the following exceptions:
  - Inspect the upper and lower bearings for wear (Refer to Arm Bearing Replacement and Shimming, Section 5.2-7).
  - Inspect the arm bar bearing contact and chamfered areas for nicks or damage. Break any sharp edges and polish with 400-grit emery paper as necessary.
  - Apply chassis grease to the bearing contact areas.

**WARNING:** Make sure the hoist used to remove the arm has a rated capacity of at least 1000 lbs. (450 kg.)

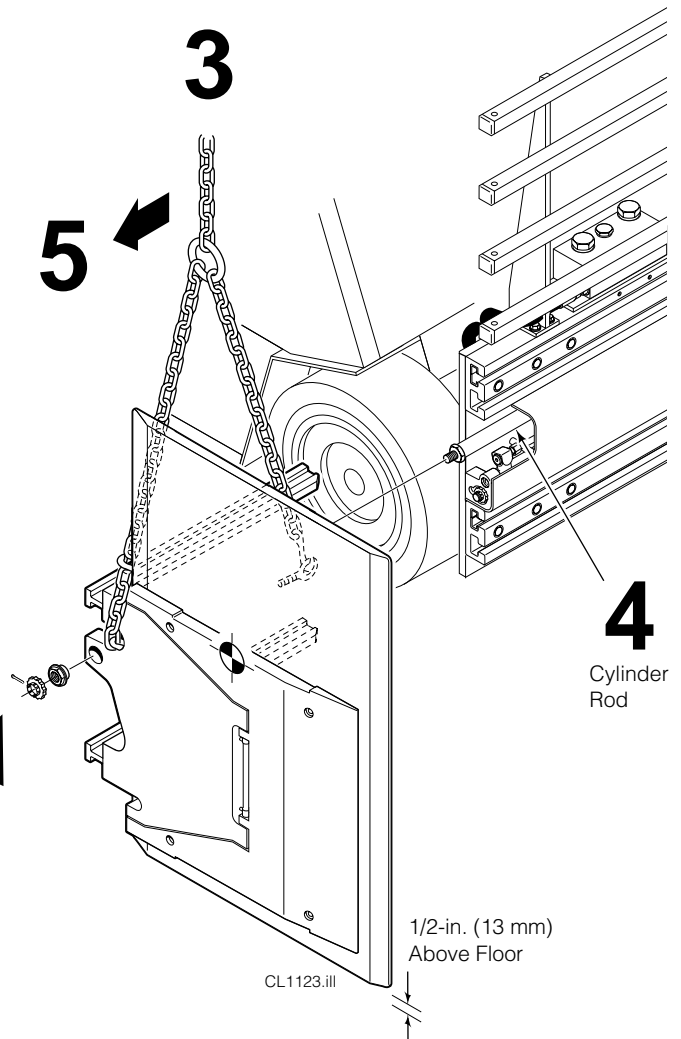
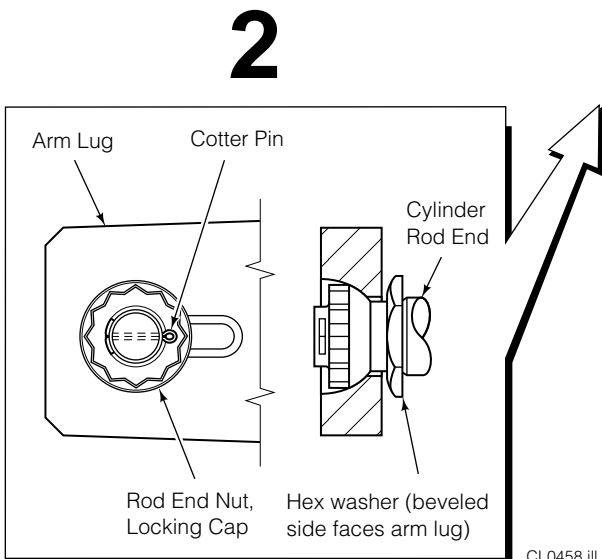

## 5.2-2 Contact Pad – Rotation or Replacement

The following procedures can be performed with the Clamp mounted on the truck.

**NOTE:** Contact pad surfaces that are worn or damaged over the entire pad area will require pad replacement. If only the lower surface is worn, the pads can be rotated 180 degrees.

- 1 Extend the arms to frame width. Lower the Clamp so that the contact pads just touch the floor.
  - 2 Remove the capscrews and nuts fastening the contact pad to the stabilizer. For reassembly, tighten the capscrews to 65 ft.-lbs. (90 Nm).
  - 3 Remove the contact pad (and tip guard if equipped) from the stabilizer. Rotate the pad 180 degrees or install a new pad.
- NOTE:** If there are shims between the stabilizer and contact pad, they must be installed in their original position to maintain the correct pad camber setting.
- 4 For reassembly, reverse the above procedures.

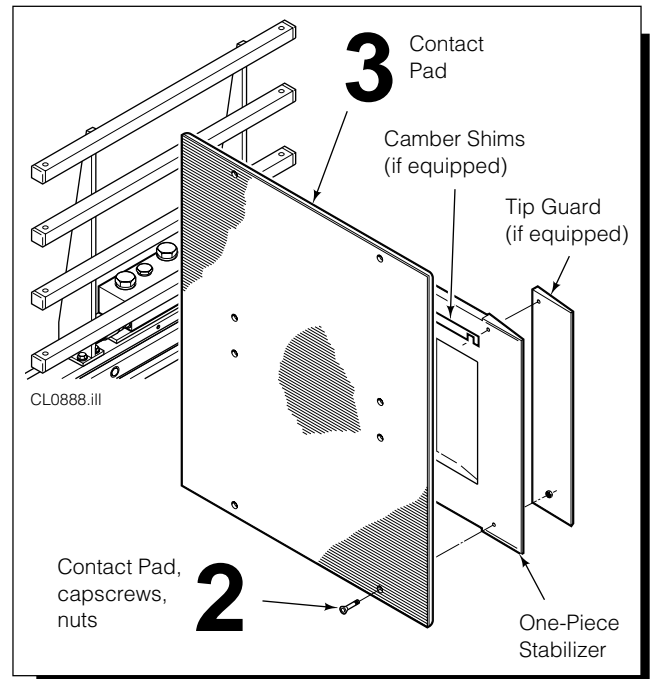

## 5.2-3 Arm Service – Clamp Arms with Eccentric Pivot Pins

The following procedures can be performed with the Clamp mounted on the truck.

- 1 Remove the contact pad and tip guard (if equipped) as described in Section 5.2-2.
  - 2 Remove the stabilizer by removing the eccentric pins. The eccentric pin is held in place by a retaining pin and snap ring. Note the position of the mark on the eccentric pin head for proper reassembly.
  - 3 Inspect the stabilizer pivot bushings. If any bushing I.D. is worn replace all bushings.
- CAUTION:** Use a bushing driver to replace the bushings in the arm. Do not damage the bushing I.D.
- 4 For reassembly, reverse the above procedures with the following exceptions:
    - Shim the pivot pins between the stabilizer and arms as shown to provide 1/16 in. (1.5 mm) clearance. The stabilizer and contact pad, when assembled, must pivot freely on the arms.
    - Assure that the pad spring is in place in the arm.

**NOTE:** Adjust pad camber (if required) by rotating the eccentric pins. Refer to Section 4.1-4 for suggested camber settings and Section 5.2-6 for camber measurement.

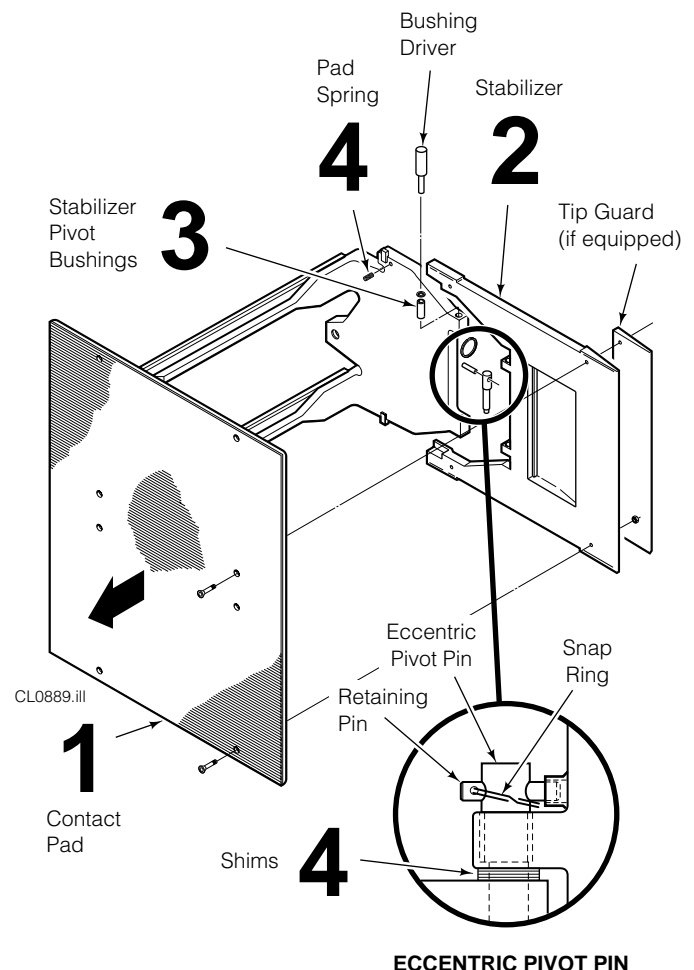

ECCENTRIC PIVOT PIN

## 5.2-4 Arm Service – Clamp Arms with Straight Pivot Pins

- 1 Remove the contact pad and tip guard (if equipped) as described in Section 5.2-2.
- 2 Remove the stabilizer pivot pins as follows:
  - A) **Pivot pins retained with plugs** – Remove the plugs from the top and bottom of the stabilizer. Note location and quantity of shims. Drive out the pivot pins and remove the stabilizer and spring.
  - B) **Pivot pins retained with dowel pins** – Remove the dowel pins from the pivot pins. Note location and quantity of shims. Drive out the pivot pins and remove the stabilizer and pad spring.
- 3 Inspect the stabilizer pivot bushings. If any bushing I.D. is worn replace all bushings.
 

**CAUTION:** Use a bushing driver to replace the bushings in the arm. Do not damage the bushing I.D.
- 4 For reassembly, reverse the above procedures with the following exceptions:
  - Shim the pivot pins between the stabilizer and arms as shown to provide 1/16 in. (1.5 mm) clearance. The stabilizer and contact pad, when assembled, must pivot freely on the arms.
  - Assure that the pad spring is in place and properly retained by the pivot and dowel pins.

**NOTE:** Adjust pad camber (if required) by adding shims between the pad and stabilizer. Refer to Section 4.1-4 for suggested camber settings and Section 5.2-6 for camber measurement and adjustment.

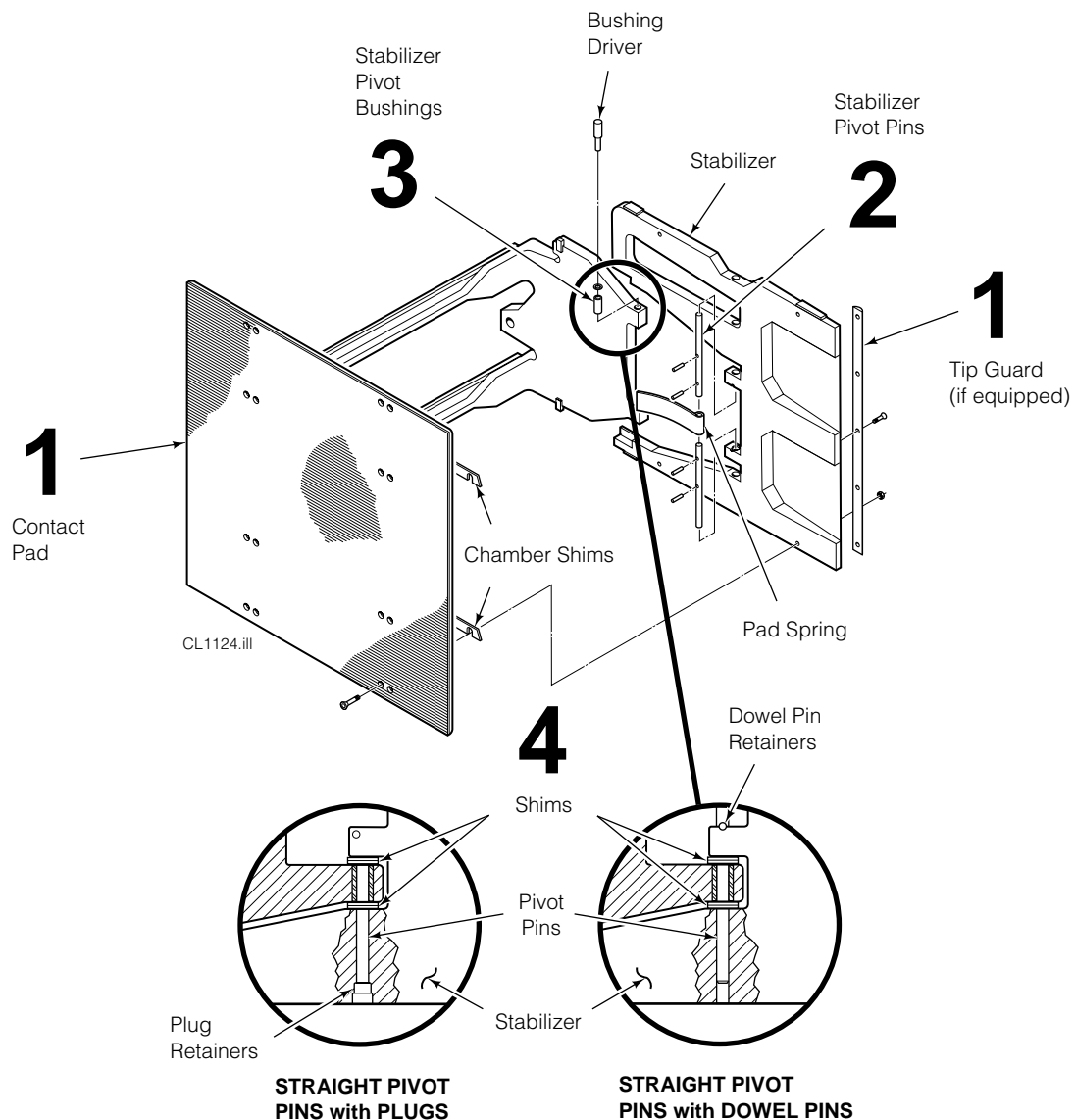

## 5.2-5 Contact Pad and Stabilizer Repair

The following procedures can be performed with the arms in place and the Clamp mounted on the truck.

- 1 Extend the arms to frame width. Lower the contact pads so that they just touch the floor.
- 2 Remove the contact pad from the Clamp as described in Section 5.2-2.
- 3 Inspect the contact pad for flatness and replace or straighten as required. Inspect the contact pad mounting holes for wear or elongation. Repair using Hole Service Kit 676841.
- 4 Remove the stabilizer from the arm as described in Section 5.2-3 or 5.2-4.
- 5 Inspect the wear tiles on the bottom surface of each stabilizer and/or tip guard for wear and replace as necessary. Grind any remaining hardfacing from both ends of the stabilizer and/or tip guard bottom surface.

**IMPORTANT:** If wear extends into the stabilizer bottom surface, build up with weld and grind flat to within 1/16 in. (1.5 mm) along the full length of the stabilizer.

- 6 Weld new wear tiles to the **bottom surface of each stabilizer** using AWS E-7018, 3/16-in. (5 mm) dia. rod.

### One-Piece Stabilizer

- Service Kit Part No. 674141 – Four (4) wear tiles to repair both stabilizers.

### Stabilizer with Tip Guard

- Stabilizer Wear Tile Part No. 675614 – Two (2) tiles required for each stabilizer.

### Tip Guard Wear Tiles

- R.H. Tip Wear Tile Part No. 678666
- L.H. Tip Wear Tile Part No. 678665

**NOTE:** Weld only to the steel backing of the wear tile. Weld will not stick to the wear tile hard surfacing.

- 7 Grind the weld along the inside edge of the stabilizer flush with the inside surface. The contact pads must bolt up flat against the stabilizer without interference from the welds.
- 8 For reassembly, reverse the above procedures.

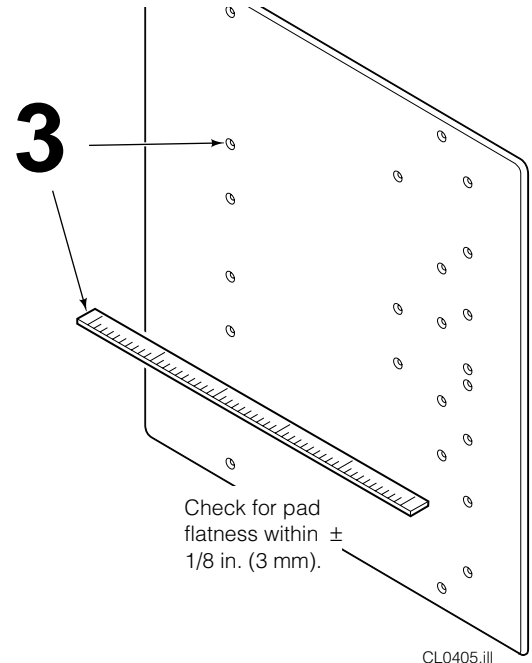

CL0405.iii

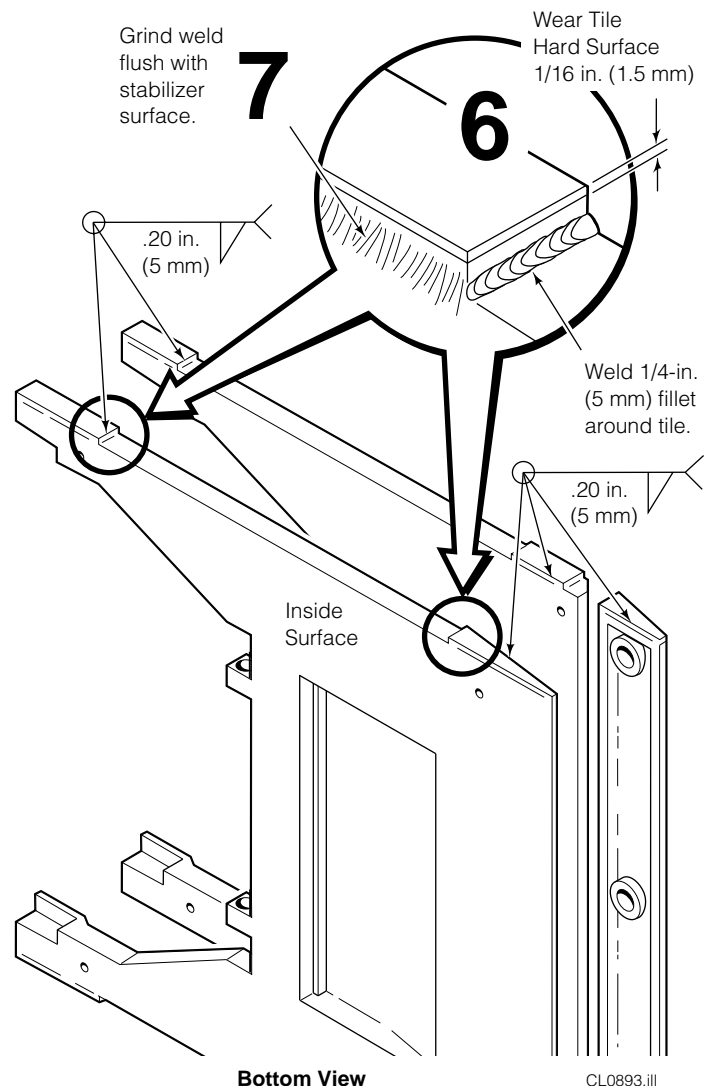

Bottom View

CL0893.iii

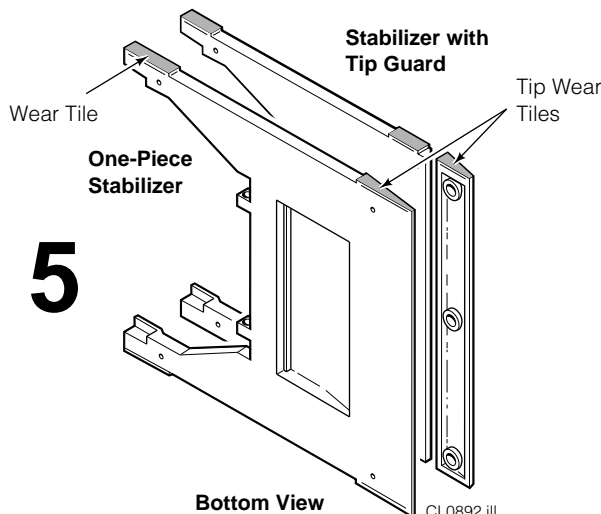

Bottom View

CL0892.iii

## 5.2-6 Contact Pad Camber Adjustment

The following procedures can be performed with the arms in place and the Clamp mounted on the truck.

- 1 Extend the arms to frame width. Lower the contact pads so that they just touch the floor.
- 2 Measure the distance between the pads in two places: at the bottom center (in line with the pivot pins), and 24 in. (60 cm) above the pad bottom centers as shown. The difference between the two measurements is the pad camber.
- 3 Determine the camber adjustment required. See Troubleshooting Section 4.1-4.

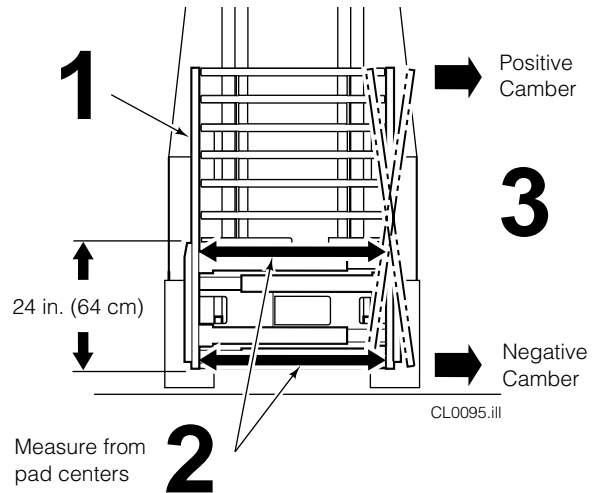

### Clamps with Eccentric Pivot Pins

- Remove the retaining pin from the eccentric pivot pin by winding the snap ring off the pin.
- Depending on the pad camber required, rotate the eccentric pivot pin 180 degrees to reposition stabilizer relative to arm. **NOTE:** Stabilizer and arm flush at top with stabilizer inset at bottom provides maximum *positive* camber. Stabilizer and arm flush at bottom with stabilizer inset at top provides maximum *negative* camber.
- Reinstall the retaining pin and snap ring. **NOTE:** Wind the snap ring clockwise (CW) on the left pad, counter-clockwise (CCW) on the right pad.

**CAUTION:** Adjust pad camber the same on both sides of the Clamp for proper load handling.

### Clamps with Straight Pivot Pins

- Loosen the contact pad capscrews and nuts and install shims as required. **NOTE:** Installing shims at the bottom of the pad provides *positive* camber. Installing shims at the top of the pad provides *negative* camber.
- Tighten the pad capscrews to 65 ft.-lbs. (90 Nm).

**CAUTION:** Use an equal number of shims on each contact pad. Pad camber must be the same on both sides of the Clamp for proper load handling.

### CAMBER ADJUSTMENT with ECCENTRIC PINS

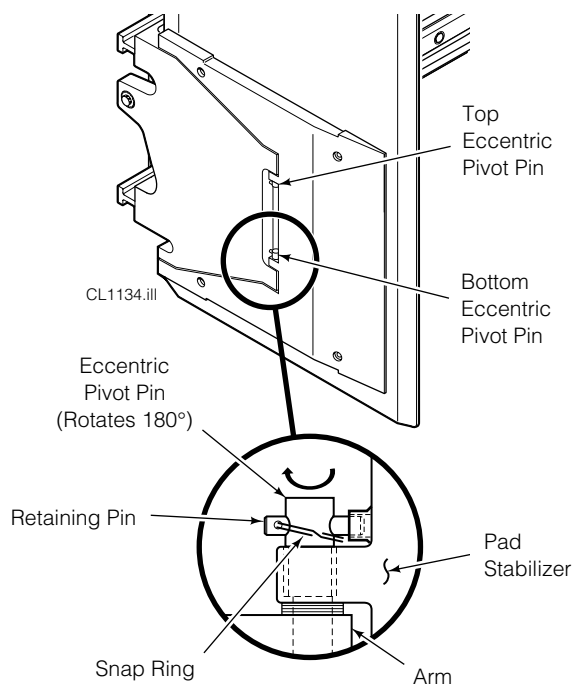

### CAMBER ADJUSTMENT with SHIMS

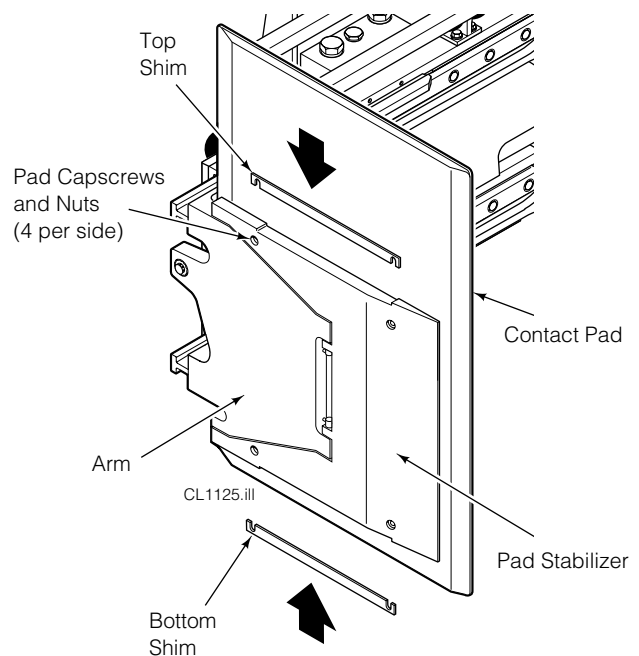

## 5.2-7 Arm Bearings – Replacement and Shimming

The following procedure can be performed with the Clamp mounted on the truck.

- 1 Remove the arm assemblies from the Clamp as described in Section 5.2-1.
- 2 Remove the bearing spacer located between the upper and lower bearing strips in each arm carrier slot.
- 3 Use a screwdriver to disengage the bearing's innermost boss and pry the bearing strips out of the frame. Slide the bearings outward.

**CAUTION:** Do not gouge aluminum frame surfaces.

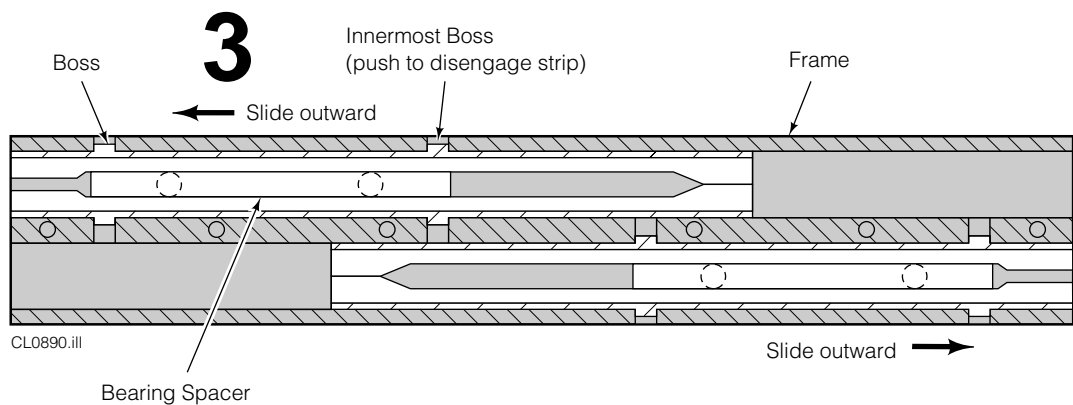
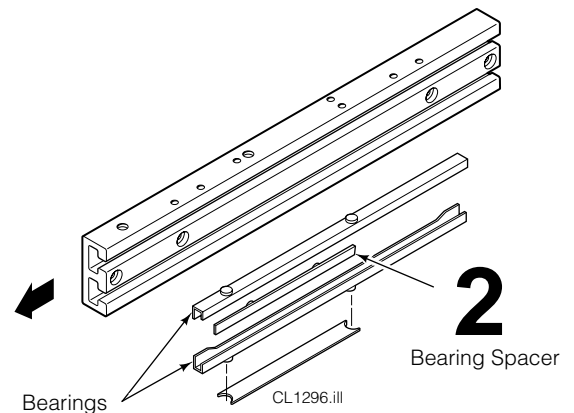

- 4 Use dial calipers to measure dimension **A** of both ends of arm bearing openings in upper and lower aluminum frames.
- 5 Place an upper and lower bearing on each arm bar. Measure dimension **B**.
- 6 Determine the shim thickness required to leave .015 in. (.38 mm) clearance between each set of bushing strips and each arm bar opening. Use the following formula:

**[A – clearance – B] = shim thickness required**

**Example: A = 2.165 in. (54.99 mm)**

**B = 2.085 in. (52.96 mm)**

U.S.: **[2.165 – .015 – 2.085] = .065 in.**

Metric: **[55.99 – .38 – 52.96] = 1.65 mm**

Pink shim = .015 in. (.38 mm)

Yellow shim = .020 in. (.50 mm)

**Use 3 yellow shims** to come closest to the required clearance: .020 in. x 3 = .060 in. (.50 mm x 3 = 1.50 mm)

- 7 Decrease the width of the bearing spacer to the dimension shown to provide room to install the shimmed bearings.
- 8 Tape the required shims for each arm bar opening to the **lower** bearing only. Install the bearings and bearing spacers.
- 9 Lubricate the bearings with light grease
- 10 For reassembly, reverse the above procedures with the following exceptions:
  - Manually check arms for freedom of movement.

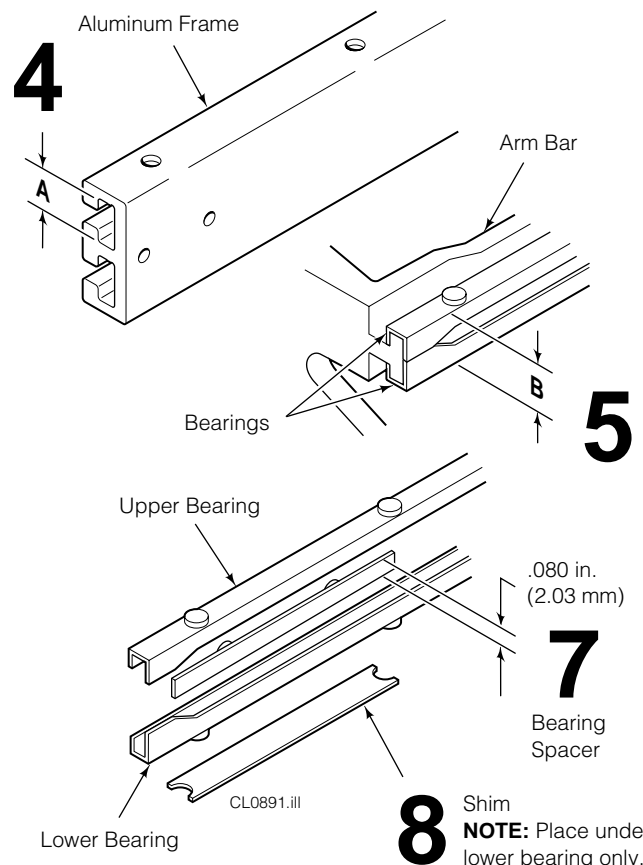

**8 Shim**  
**NOTE:** Place under lower bearing only.

## 5.3 Valve

### 5.3-1 Valve Removal and Installation

The Clamp must be removed from the truck in order to service the valve.

- 1 Remove the Clamp from the truck as described in Section 5.1.
- 2 Disconnect the cylinder tubes/hoses from the bottom of the Valve. Plug the ends and tag for reassembly.
- 3 Disconnect the supply hoses from the sides of the Valve. Plug the hose ends and tag for reassembly.
- 4 Remove the capscrews fastening the Valve mounting plate to the frame. For reassembly, tighten the capscrews to 15 ft.-lbs. (20 Nm).
- 5 Remove the two (2) flathead capscrews fastening the valve to the mounting plate. For reassembly, tighten the capscrews to 15 ft.-lbs. (20 Nm).
- 6 For reassembly, reverse the above procedures with the following exceptions:
  - Service the Valve as described in Section 5.3-3.

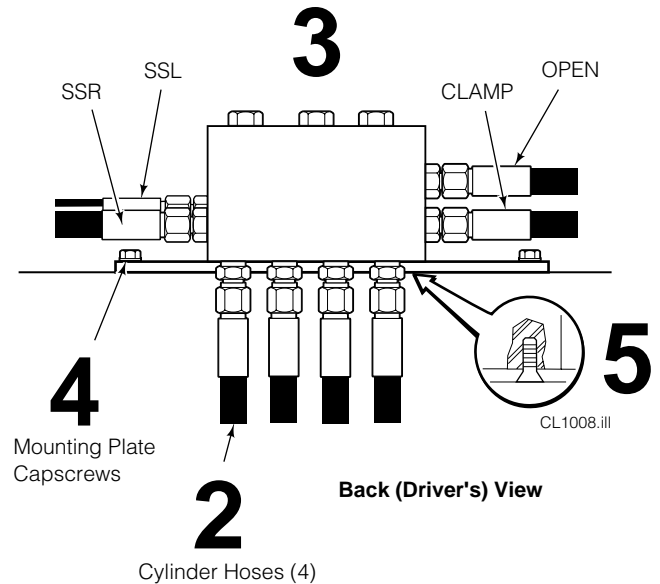

### 5.3-2 Eliminating Regenerative Circuit (fast arm opening)

The regenerative circuit can be deactivated to reduce the arm opening speed. This procedure can be accomplished with the Clamp mounted on the truck.

- 1 Open the Clamp arms to frame width.



**WARNING:** Before removing hydraulic lines or components, relieve pressure in the Attachment hydraulic system. Turn the truck off and move the auxiliary control levers several times in both directions.

- 2 Disconnect the hydraulic hose from the Valve CLAMP (CL) port.
- 3 Remove the special fitting and spool.
- 4 Install a 1/4-in. NPTF pipe plug within the port.
 

**NOTE:** Thread seat for pipe plug is approximately 4 in. (10 cm) inside port (see illustration).
- 5 For reassembly, reverse the above procedures with the following exceptions:
  - **Do not** reinstall spool in port.
  - Make sure special fitting is reinstalled in CLAMP (CL) port.

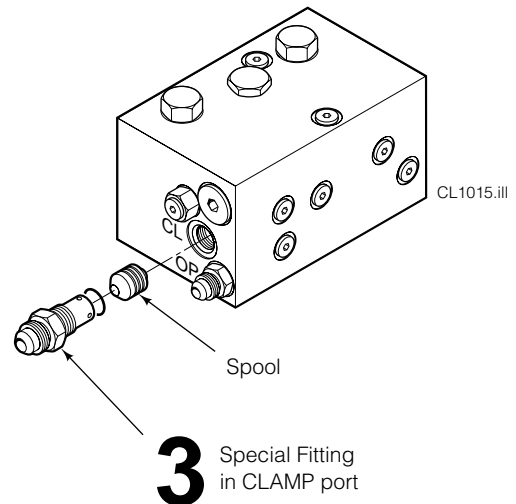

**WARNING:** Special fitting must be reinstalled in CLAMP (CL) port. Clamp arms will not function properly without special fitting installed.

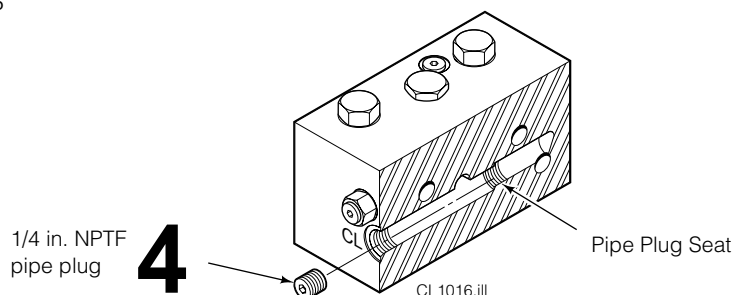

## 5.3-3 Valve Service

**IMPORTANT:** Service the Valve in a clean work area.

- 1 Remove the Valve from the Clamp as described in Section 5.3-1.
  - 2 Remove the sideshift and clamp check valve cartridges. For reassembly, tighten cartridges to 50 ft.-lbs. (65 Nm).
  - 3 Remove the special fitting and spool.
  - 4 Remove the relief valve components.
  - 5 Remove the flow divider components.
- CAUTION:** Do not disassemble the flow divider spools.
- 6 Remove the remaining plugs and fittings.
  - 7 Remove the O-rings and back-up rings from the cartridge valves, fittings and plugs.
  - 8 Clean all parts with cleaning solvent or kerosene.
  - 9 For reassembly, reverse the above procedures with the following exceptions:

- Replace O-rings and back-up rings on cartridges and fittings as shown below.
- Lubricate cartridges, fittings and plugs with petroleum jelly prior to installation.
- If required for low-flow trucks, install Service Kit 679846 on flow divider spool as shown.

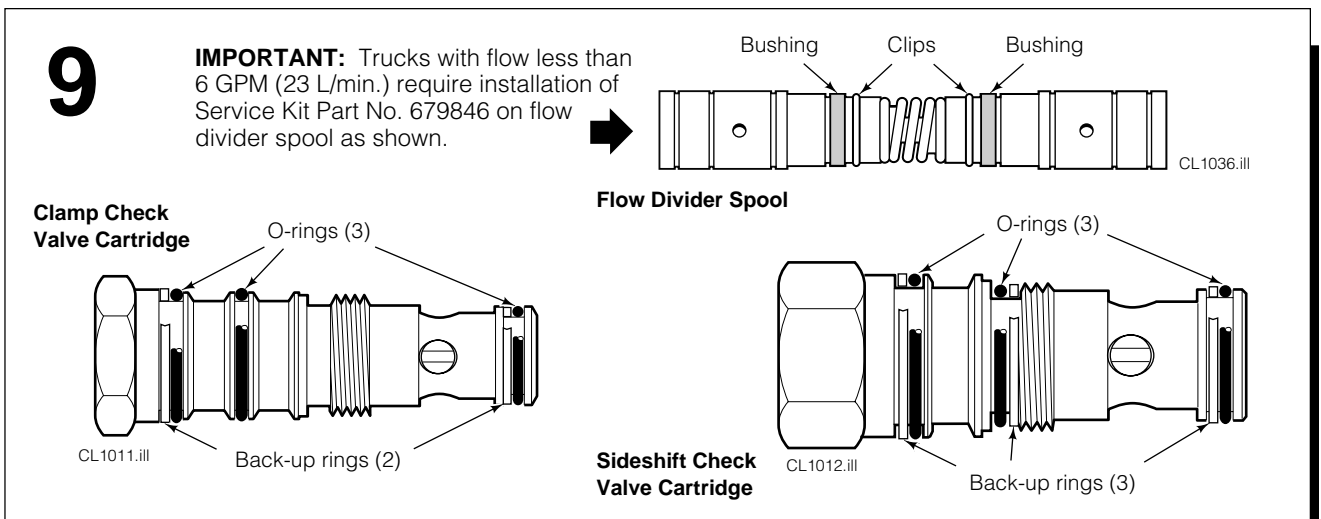
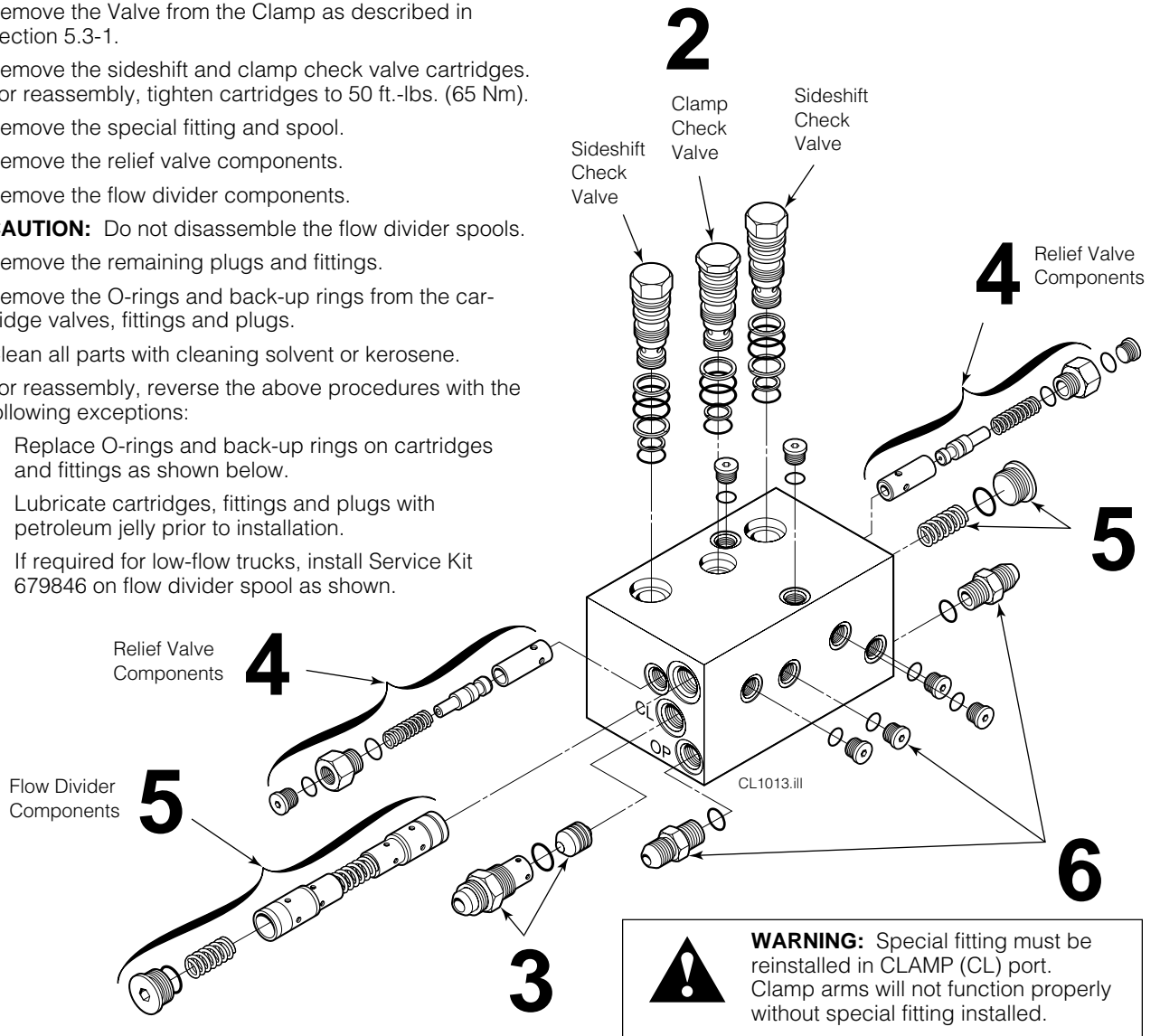

## 5.4 Cylinders

### 5.4-1 Cylinder Removal and Installation

**NOTE:** The following procedures can be performed with the Clamp mounted on the truck and the arms remaining on the Attachment.

- 1 Extend the arms outside the width of the frame.
- 2 Remove the bumper capscrews (2) and nuts (2) on each side and remove the bumper from the Clamp. For reassembly, screw the self-locking nut onto the capscrew to leave .050-.080 in. (1.3-2.0 mm) end play for bumper flex during operation.
- 3 Disconnect the cylinder rod end by removing the cotter pin, locking cap and spherical nut.
- 4 Retract the cylinder rods until they disengage from the arm lugs.



**WARNING:** Before disconnecting hydraulic lines, relieve pressure in the Attachment hydraulic system. Turn the truck off and move the auxiliary control levers several times in both directions.

- 5 Disconnect the hydraulic lines from the cylinder ports. Plug the lines and cap the cylinder ports. Tag lines for reassembly (see Section 5.1 for hose connections).
- 6 Disconnect the cylinder head end from the frame lug by removing the cotter pin, lock cap and spherical nut.
- 7 Lift cylinders away from the Clamp frame.
- 8 For reassembly, reverse the above procedures with the following exceptions for the cylinder anchors:
  - Lubricate threads with chassis grease.
  - Install hex beveled washer on cylinder rod end. **NOTE:** Make sure beveled side faces lug as shown.
  - Tighten spherical nuts to 160 ft.-lbs. (220 Nm). **NOTE:** Nut tightens against hex washer, providing a loose operating clearance. Lubricate anchor joints with chassis grease.
  - Install locking caps using new cotter pins.

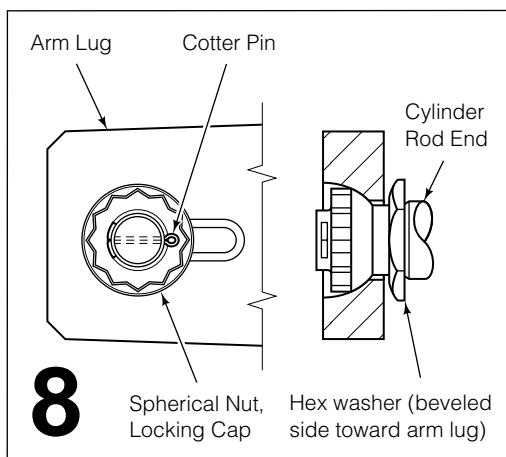

CL0458.iii

2

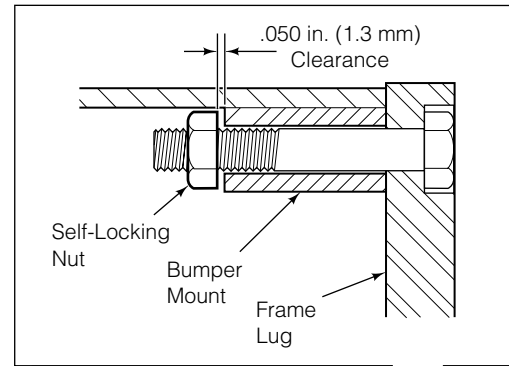

CL1081.iii

1

3

6

2

CL1126.iii



**WARNING:** After completing this service procedure, test the Clamp through five complete cycles. First test empty, then test with a load to make sure the Clamp operates correctly before returning to the job.

## 5.4-2 Cylinder Disassembly

- 1 Clamp the cylinder in a soft-jawed vise at the extreme head end only. Do not clamp on the shell.
- 2 Remove the retainer using a claw-type spanner wrench as shown. (Cascade Part No. 678598)
- 3 Remove the rod/piston assembly from the cylinder.
- 4 To remove the piston, clamp the rod assembly in a vise on the wrench flats as shown. **CAUTION:** Do not clamp on the cylinder rod sealing surface.
- 5 Remove the piston nut and remove the piston from the cylinder rod.
- 6 Place the piston or retainer in a soft-jawed vise to remove the seals. Pry the seals or O-rings up with a brass seal removal tool (Cascade Part No. 674424) and cut the seals to remove them. **CAUTION:** Do not scratch seal grooves.

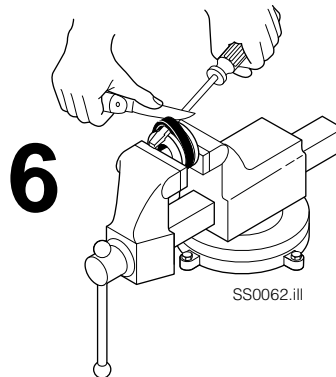
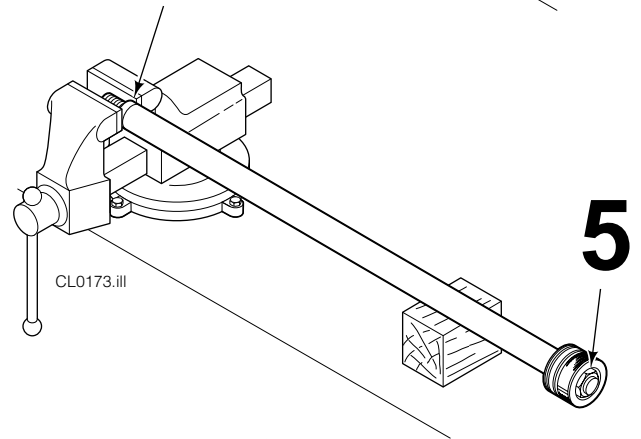
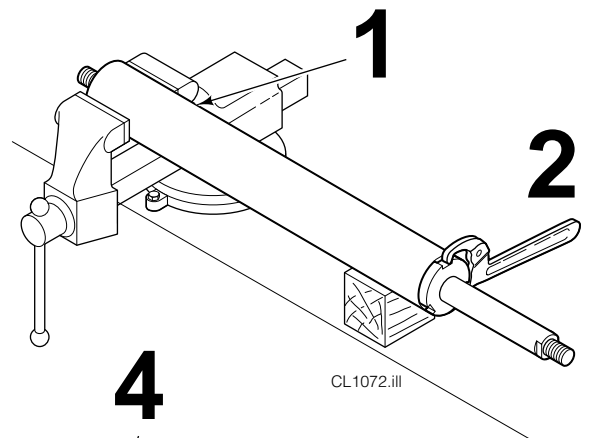

## 5.4-3 Cylinder Inspection

- Inspect the rod, piston and retainer for nicks or burrs. Minor nicks or burrs may be removed with 400-grit emery cloth. If they cannot be removed, replace the parts.
- Inspect the cylinder bore and remove any minor nicks or burrs with a butterfly. If they cannot be removed, replace the part.
- Inspect the outside of the shell for any deformities or cuts that could impair performance or cause leaks under pressure. If necessary, replace the part.
- Inspect the spherical nuts and hex washer for wear and replace as necessary.

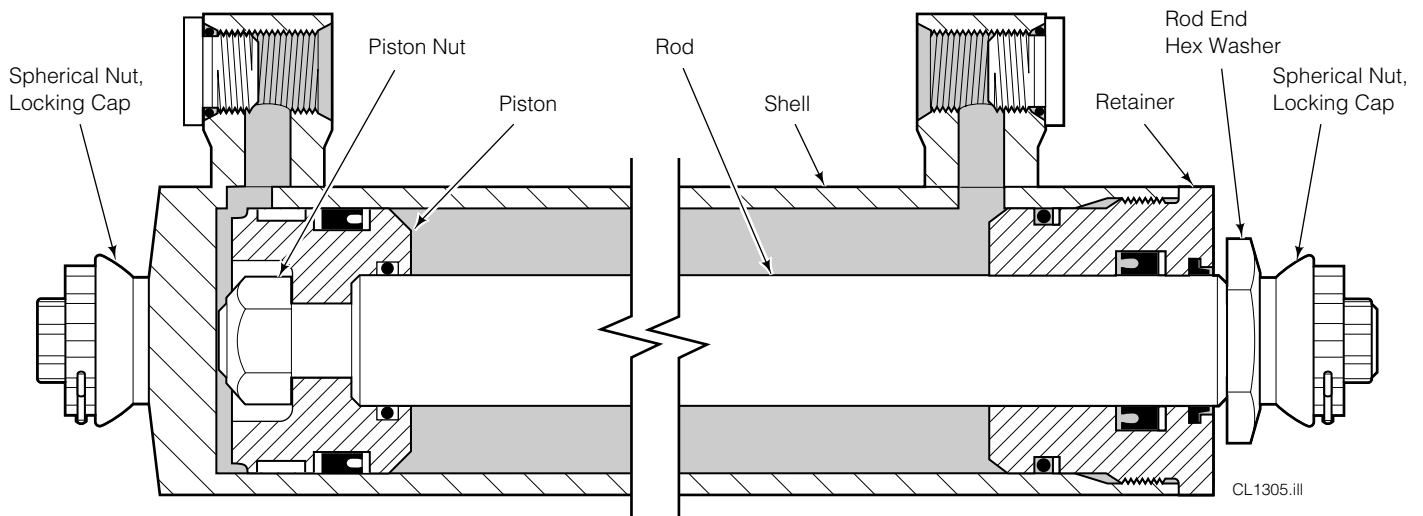

## 5.4-4 Cylinder Reassembly

- 1 Lubricate all new seals and O-rings with petroleum jelly.
- 2 Note the direction of the U-cup seals. **Pressure seals must be installed with the lip toward the high pressure side of the cylinder.**
- 3 Polish the piston and retainer chamfer angles with 400-grit emery cloth to ease seal installation.
- 4 Install a new seal and O-ring on the piston. Install the piston seal from the rod end side of the piston by hooking one side into the groove and carefully working the seal over the piston as shown.
- 5 Install a new rod seal, back-up ring, and wiper seal in the retainer I.D., and a new O-ring and back-up ring on the retainer O.D. as shown. **NOTE:** Use internal seal installation tool (Cascade Part No. 599512) to ease seal installation. If installing by hand, form the seal into a 'kidney' shape and position into the internal groove. Use finger pressure to smooth the seal into the groove.
- 6 Apply petroleum jelly to the piston internal O-ring and install the piston on the rod. Tighten the nut as follows:
  - 15D, 20D, 25D, 35D – 65 ft.-lbs. (85 Nm)
  - 50D, 60D – 100 ft.-lbs. (135 Nm)
- 7 Place the piston loader into the cylinder shell.
 

**IMPORTANT:** The loader must cover all of the shell threads but not contact the thread relief chamfer. If necessary, trim the stop fins for a correct fit. The piston will not enter the shell if the loader contacts the thread relief chamfer.
- 8 Apply a thick film of petroleum jelly to the piston, shell and loader. Using a rubber mallet, tap the piston/rod assembly into the cylinder shell.
- 9 Place the retainer loader over the rod end threads. Apply petroleum jelly to the retainer I.D. and slide it onto the rod. Remove the loader and screw the retainer into the shell. Tighten the retainer as follows:
  - 15D, 20D, 25D, 35D – 75–125 ft.-lbs. (100–170 Nm)
  - 50D, 60D – 150–200 ft.-lbs. (200–270 Nm)

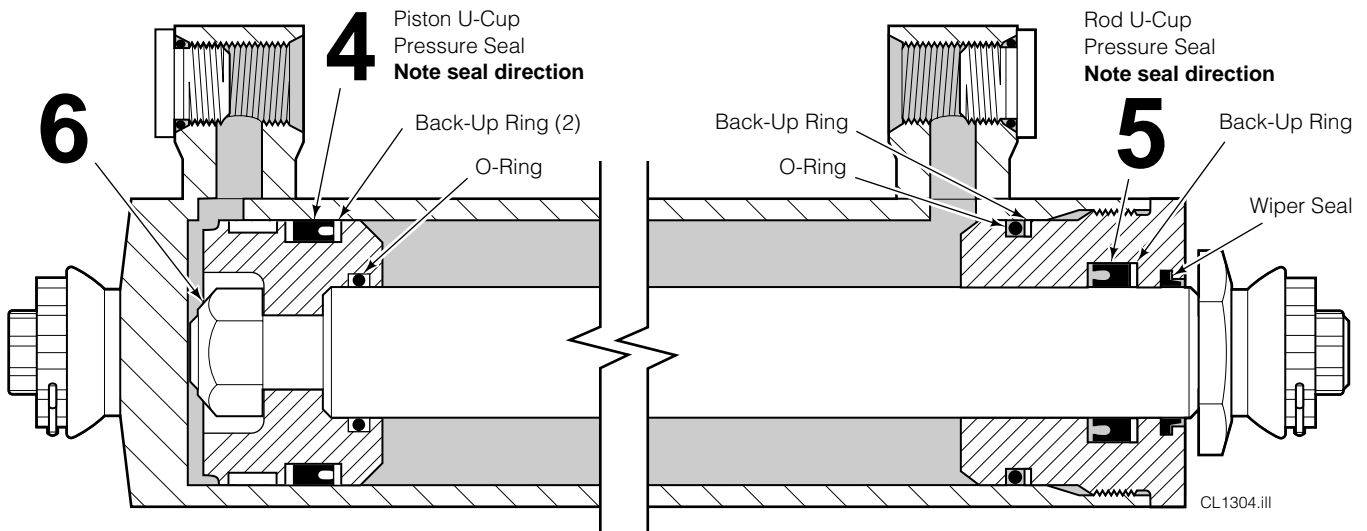
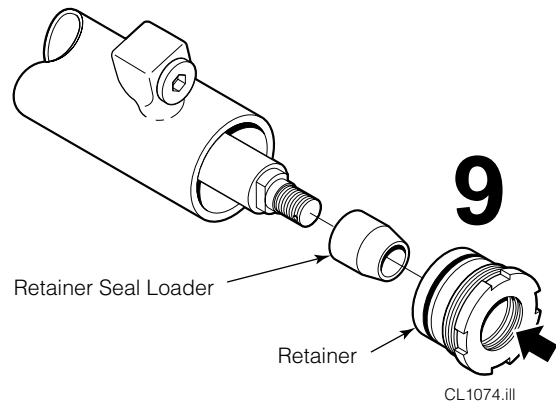
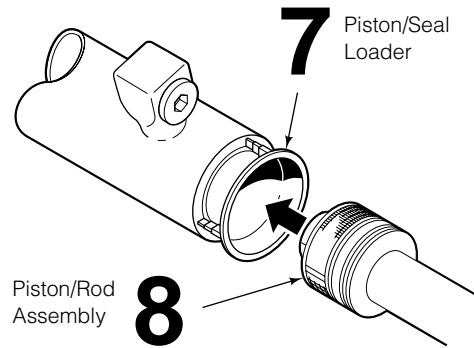
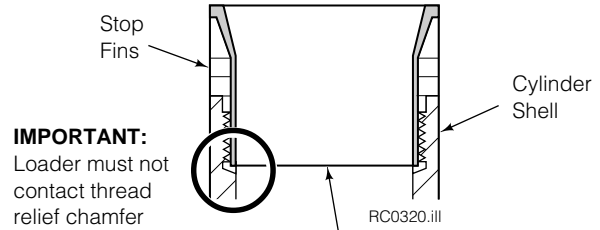
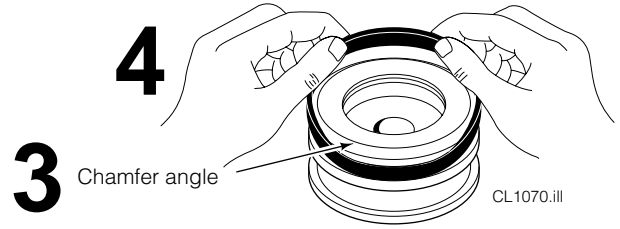

## 5.5 Base Unit

### 5.5-1 Frame and Mounting Plate – Disassembly and Reassembly

- 1 Remove the contact pads and stabilizers as described in Section 5.2-3 or 5.2-4. **NOTE:** Pad and stabilizer can be removed as a unit by removing the pivot pins only.
- 2 Remove the cylinders as described in Section 5.4-1.
- 3 Disconnect and plug the supply hoses to the Clamp. Tag hoses for reassembly.

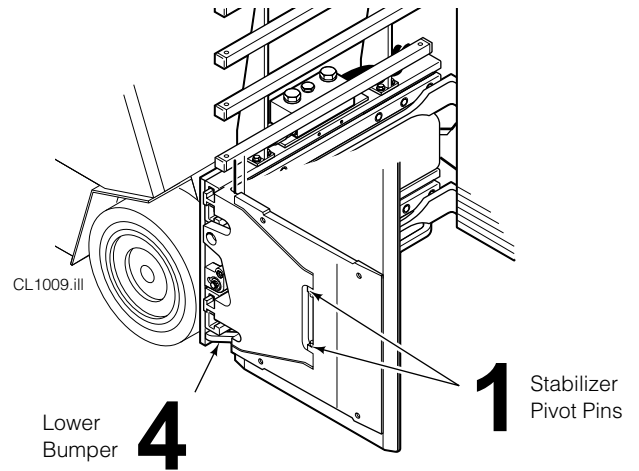
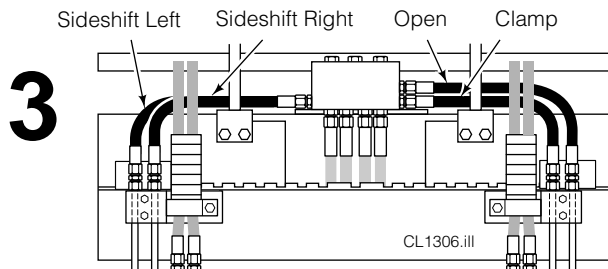

**WARNING:** Make sure hoist has a rated capacity of at least 2500 lbs. (1150 kg.)

- 4 Remove the lower bumper. For reassembly, tighten the capscrews to 40 ft.-lbs. (55 Nm).

- 5 Disconnect the lower hooks:

**Quick-Change Hooks** – Remove the locking pins and drop the hooks (new type) or rotate hooks (early type) into the unlocked position. Replace the pins in the lower holes. For reassembly, remove the pins and slide the hooks up (new type) or rotate hooks (early type) into the locked position. Replace the pins in the top holes.

**Bolt-On Hooks** – Remove the capscrews and mounting hooks. For reassembly, tap the hooks tight against the carriage bar and tighten the capscrews to 110 ft.-lbs. (150 Nm).

- 6 Attach an overhead hoist to the backrest cutout holes as shown and remove the Clamp from the truck.

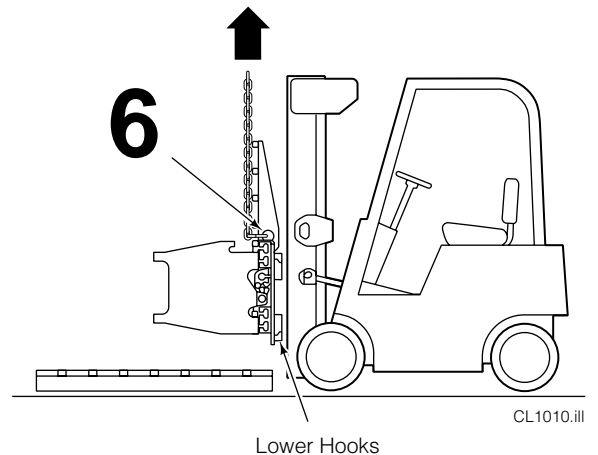

## 5

### QUICK-DISCONNECT LOWER HOOKS

(New Type)

(Early Type)

### BOLT-ON LOWER HOOKS

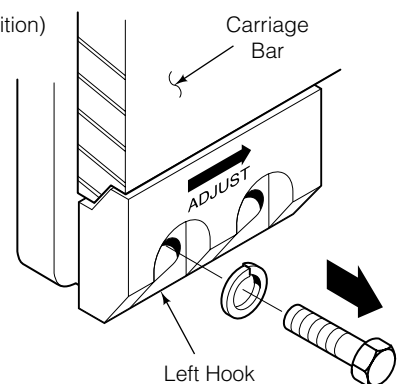
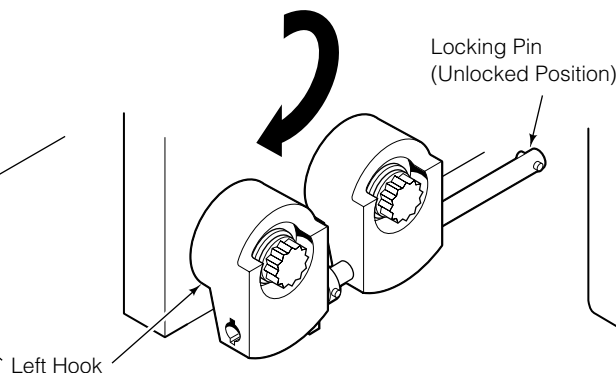
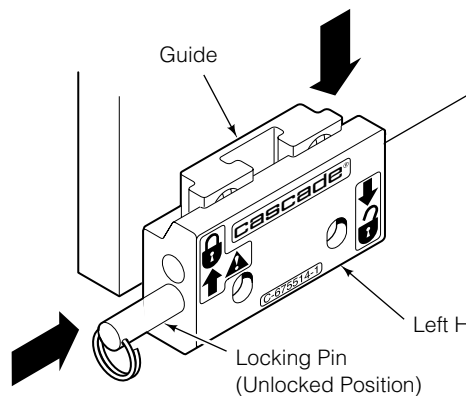

## 5.5-1 Frame and Mounting Plate – Disassembly and Reassembly (Continued)

- 7 Remove the Clamp from the truck carriage and set on a pallet.
- 8 Remove the backrest. For reassembly, tighten the backrest (Cascade) capscrews to 75 ft.-lbs. (100 Nm). For other backrests, refer to manufacturer's specifications.
- 9 Disconnect and remove the four (4) tubes or hoses from the bottom of the Attachment valve. Tag for reassembly.
- 10 Remove the capscrews fastening the valve mounting plate to the frame and remove the valve. For reassembly, tighten the capscrews to 15 ft.-lbs. (20 Nm).
- 11 Using the overhead hoist, lay the Clamp over on it's back with the mounting plates down.
- 12 Pull the arms out of the frames.
- 13 Inspect the arm bearings for wear and replace as necessary (see Section 5.2-7).
- 14 Remove the capscrews fastening each frame to the mounting plates and remove the frames. Tag frames for reassembly in the same location.
- 15 For reassembly, reverse the above procedures with the following exceptions for the aluminum frames:

- Use a straight edge as necessary to align top edges (upper hook side) of mounting plates (see illustration).

**NOTE:** Apply Loctite 242 (blue) to all capscrews.

- Install upper aluminum frame on mounting plates and lightly tighten capscrews. Assure frame is parallel to edge of mounting plates within .030 in. (.8 mm).
- Install lower aluminum frame on mounting plates and lightly tighten capscrews. Tighten upper frame capscrews to 75 ft.-lbs. (100 Nm).
- Install arms into frames. **NOTE:** Assure that arms move freely and have unrestricted travel. Adjust lower frame if required.
- Tighten lower frame capscrews to 75 ft.-lbs. (100 Nm).

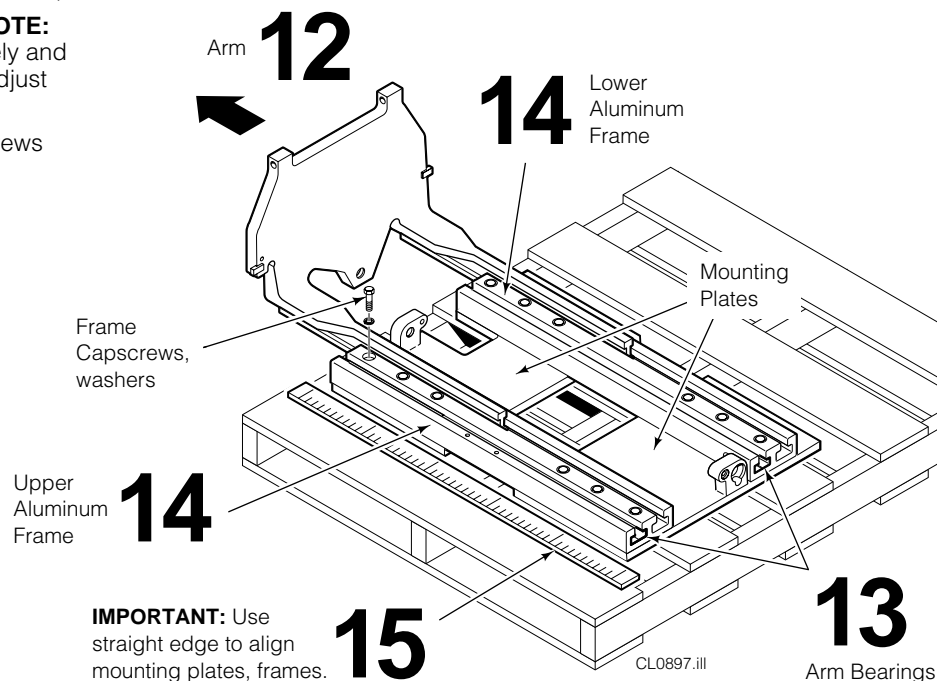
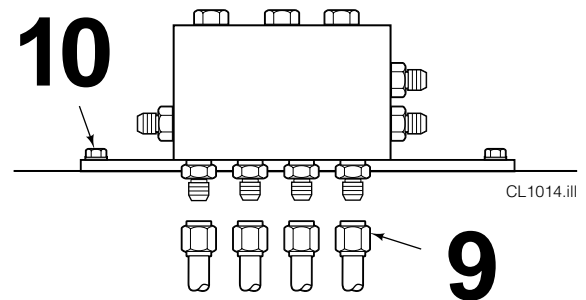
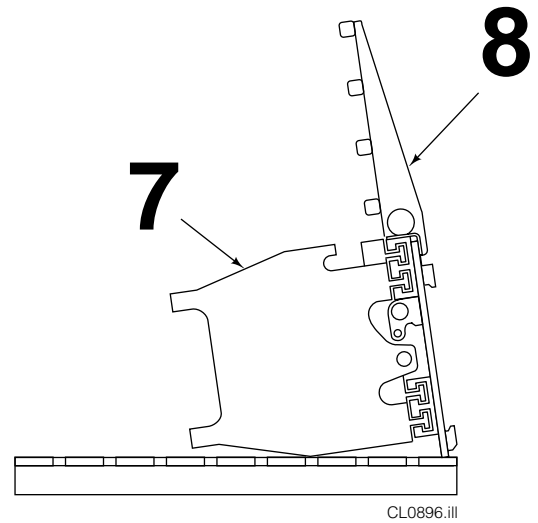

**IMPORTANT:** Use straight edge to align mounting plates, frames.

## 5.6 Solenoid Valve

### 5.6-1 Coil Service

- 1 Remove the cover from the valve assembly (if equipped).
- 2 Disconnect the wires and diode from the coil terminals.
- 3 Loosen the end cover capscrews. Remove the end cover and coil.
- 4 Install the new coil and end cover. Assure that the terminals are positioned correctly.
- 5 For reassembly, reverse the above procedures except as follows:
  - Refer to the electrical schematic in Section 4.5 for correct wire and diode installation.

### 5.6-2 Valve Service

- Check the plunger within the valve body for freedom of movement. Press end button on coil to assure that valve is not jammed or damaged. If problems are found, replace the solenoid valve as a complete assembly

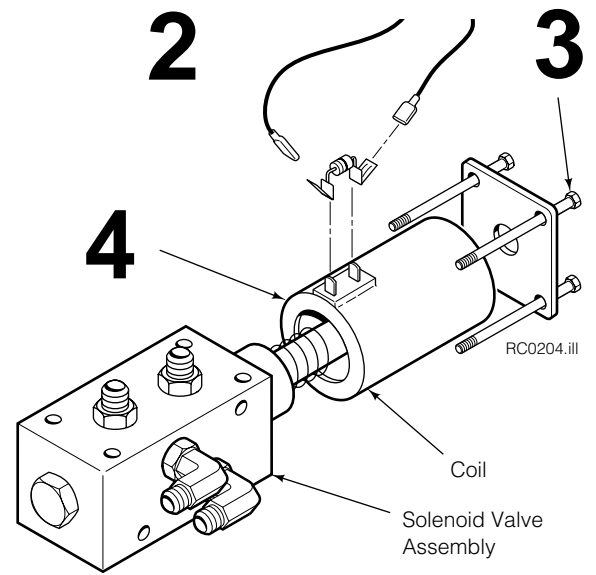

## 6.1 Specifications

### 6.1-1 Hydraulics

#### Truck Relief Setting

2000 psi (140 bar) Recommended  
2300 psi (160 bar) Maximum

#### Truck Flow Volume <sup>①</sup>

	Min. <sup>②</sup>	Recommended	Max. <sup>③</sup>
15D, 20D, 25D, 35D, 50D, 60D	4 GPM (15 L/min.)	7 GPM (26 L/min.)	7 GPM (26 L/min.)

① Cascade D-Series Clamps are compatible with SAE 10W petroleum base hydraulic fluid meeting Mil. Spec. MIL-0-5606 or MIL-0-2104B. Use of synthetic or aqueous base hydraulic fluid is not recommended. If fire resistant hydraulic fluid is required, special seals must be used. Contact Cascade.

② Flow less than recommended will result in reduced system performance.

③ Flow greater than maximum can result in excessive heating, reduced system performance and reduced hydraulic system life.

#### Hoses and Fittings

CLAMP Function – No. 8, 13/32 in. (10 mm) minimum ID.  
SIDESHIFT Function – No. 6, 9/32 in. (7 mm) minimum ID.

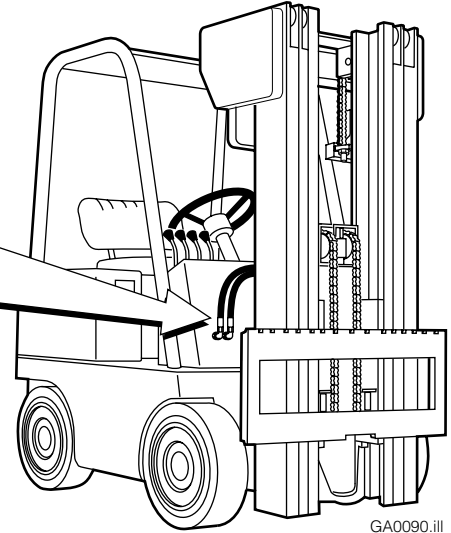

GA0090.ill

### 6.1-2 Auxiliary Valve Functions

Check for compliance with ITA (ISO) standards:

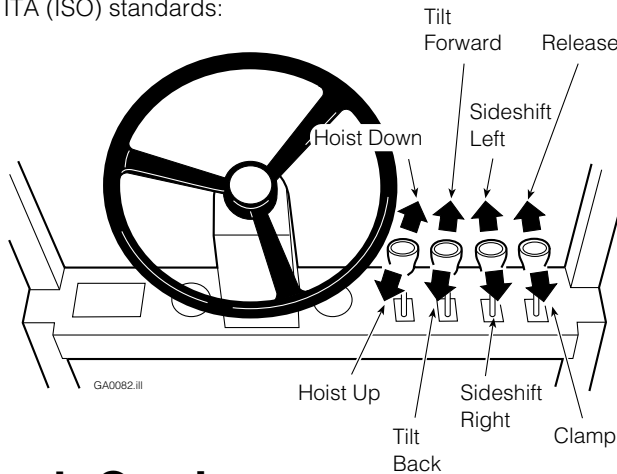

GA0082.ill

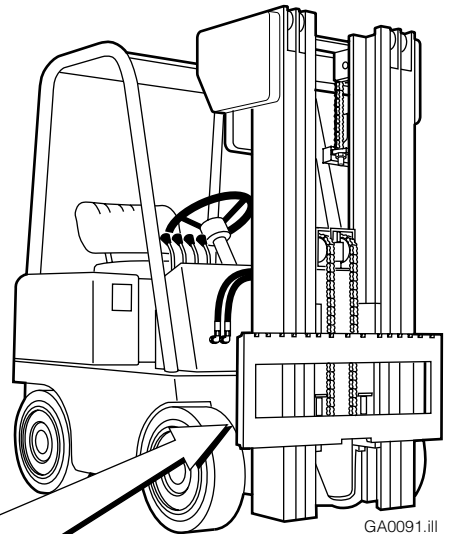

GA0091.ill

### 6.1-3 Truck Carriage



#### Carriage Mount Dimension (A) ITA (ISO)

	Minimum	Maximum
Class II	14.94 in. (380.0 mm)	15.00 in. (381.0 mm)
Class III	18.68 in. (474.5 mm)	18.74 in. (476.0 mm)

GA0028.ill

## 6.1-4 Torque Values

Fastener torque values for D-Series Clamps are shown in the table below in both U.S. and Metric units. All torque values are also called out in each specific service procedure section throughout the Manual.

Ref.	Fastener	Size	Ft.-lbs.	Nm
1	Frame-to-baseplate (★)	1/2 UNC	75	100
2	Upper hook-to-mounting plate (4)	5/8 (M16)	95	130
3	Backrest-to-baseplate (8)	1/2 (M12)	60	80
4	Cylinder piston-to-rod	5/8 UNF 7/8 UNF	65 100	90 135
5	Valve mounting plate-to-frame (2)	3/8 (M10)	15	20
6	Valve-to-mounting plate (2)	3/8 (M10)	15	20
7	Quick-Disconnect lower hook (4)	5/8 (M16)	165	225
8	Lower bumper-to-mounting plate (4)	1/2 (M12)	60	80
9	Bolt-on lower hook-to-baseplate (4)	5/8 (M-16)	110	150
10	Cylinder retainer (2)	-	100	130
11	Contact pad-to-stabilizer (8)	1/2 (M-12)	65	85
12	Tip guard-to-stabilizer (5)	M-6	10	15
13	Bumper-to-mounting lug (2)	(See Sec. 5.4-1)		
14	Cylinder anchor nut (4)	3/4 UNF	160	220

★ Number of fasteners varies depending on Model

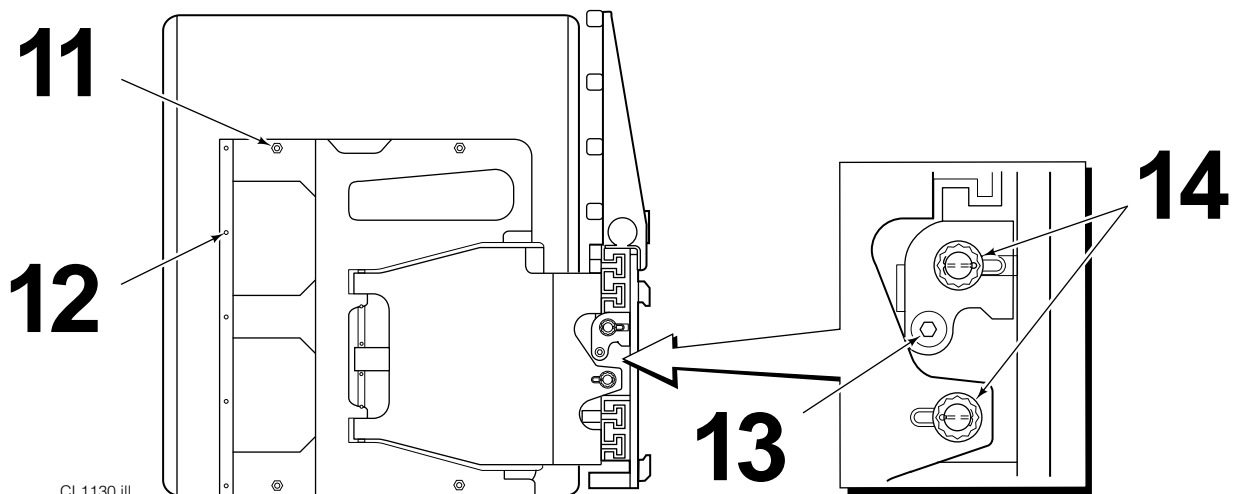
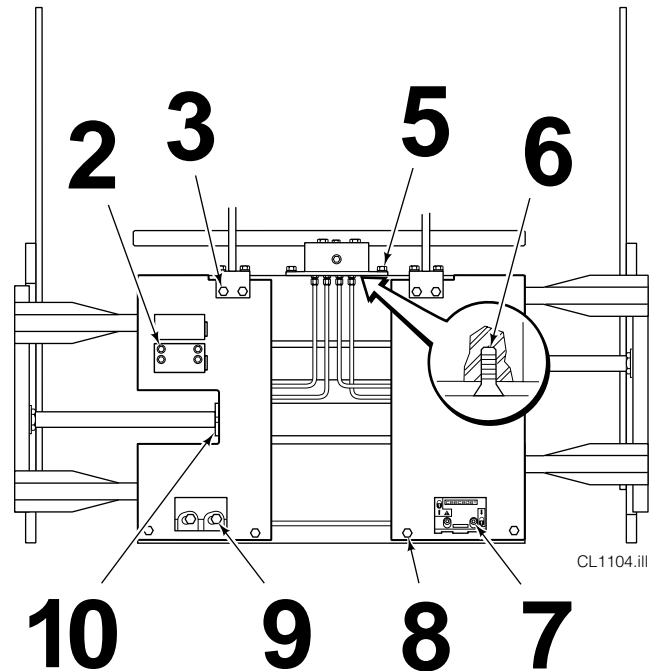
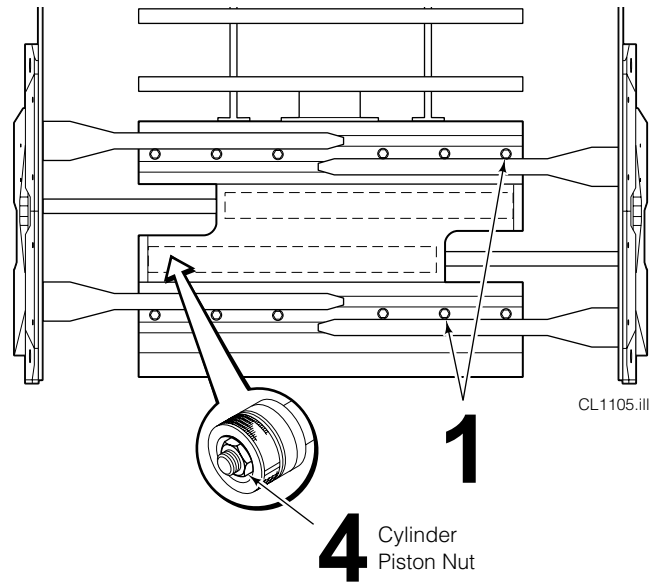

**Do you have questions you need answered right now?**

Call your nearest Cascade Service Department.

Visit us online at [www.cascorp.com](http://www.cascorp.com)

**AMERICAS**

**Cascade Corporation  
U.S. Headquarters**  
2201 NE 201st  
Fairview, OR 97024-9718  
Tel: 800-CASCADE (227-2233)  
Fax: 888-329-8207

**Cascade Canada Inc.**  
5570 Timberlea Blvd.  
Mississauga, Ontario  
Canada L4W-4M6  
Tel: 905-629-7777  
Fax: 905-629-7785

**Cascade do Brasil**  
Rua João Guerra, 134  
Macuco, Santos - SP  
Brasil 11015-130  
Tel: 55-13-2105-8800  
Fax: 55-13-2105-8899

**EUROPE-AFRICA**

**Cascade Italia S.R.L.  
European Headquarters**  
Via Dell'Artigianato 1  
37050 Vago di Lavagno (VR)  
Italy  
Tel: 39-045-8989111  
Fax: 39-045-8989160

**Cascade (Africa) Pty. Ltd.**  
PO Box 625, Isando 1600  
60A Steel Road  
Sparton, Kempton Park  
South Africa  
Tel: 27-11-975-9240  
Fax: 27-11-394-1147

**ASIA-PACIFIC**

**Cascade Japan Ltd.**  
2-23, 2-Chome,  
Kukuchi Nishimachi  
Amagasaki, Hyogo  
Japan, 661-0978  
Tel: 81-6-6420-9771  
Fax: 81-6-6420-9777

**Cascade Korea**  
121B 9L Namdong Ind.  
Complex, 691-8 Gojan-Dong  
Namdong-Ku  
Inchon, Korea  
Tel: +82-32-821-2051  
Fax: +82-32-821-2055

**Cascade-Xiamen**  
No. 668 Yangguang Rd.  
Xinyang Industrial Zone  
Haicang, Xiamen City  
Fujian Province  
P.R. China 361026  
Tel: 86-592-651-2500  
Fax: 86-592-651-2571

**Cascade India Material  
Handling Private Limited**  
No 34, Global Trade Centre  
1/1 Rambaugh Colony  
Lal Bahadur Shastri Road,  
Navi Peth, Pune 411 030  
(Maharashtra) India  
Phone: +91 020 2432 5490  
Fax: +91 020 2433 0881

**Cascade Australia Pty. Ltd.**  
1445 Ipswich Road  
Rocklea, QLD 4107  
Australia  
Tel: 1-800-227-223  
Fax: +61 7 3373-7333

**Cascade New Zealand**  
15 Ra Ora Drive  
East Tamaki, Auckland  
New Zealand  
Tel: +64-9-273-9136  
Fax: +64-9-273-9137

**Sunstream Industries  
Pte. Ltd.**  
18 Tuas South Street 5  
Singapore 637796  
Tel: +65-6795-7555  
Fax: +65-6863-1368

