

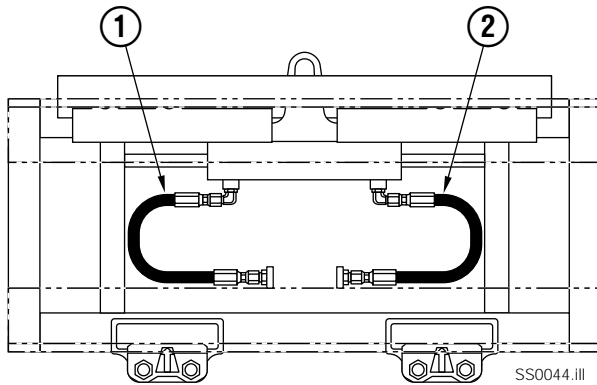

Installation Instructions

E-Series Sideshifter Installation Kits

This sheet provides instructions for Hose Installation Kit 205826 and High Termination Kit 205823 to be used with Q.D. Coupler Kit 671045. These kits provide the hoses and fittings to connect the internal reeving fittings on the truck carriage to the attachment fittings.



Hose Installation Kit 205826

REF	QTY	PART NO.	DESCRIPTION
		205826	Hose Installation Kit
1	1	200016	Hose
2	1	678027	Hose

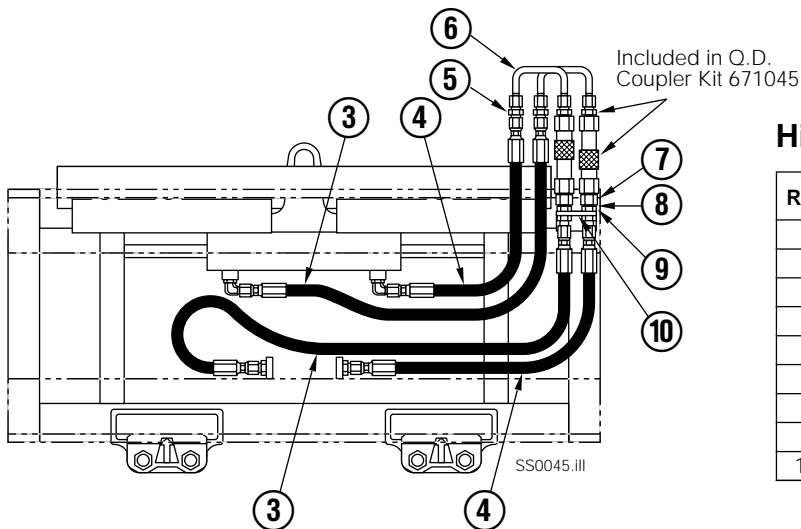

High Termination Kit 205823

REF	QTY	PART NO.	DESCRIPTION
		205823	Hose Installation Kit
3	2	682103	Hose
4	2	680461	Hose
5	2	2347	Fitting, 6-6
6	2	205824	Tube
7	2	611337	Fitting, 8-6
8	2	2840	O-ring
9	2	2375	Bulkhead Fitting, 8-8
10	1	685470	Carriage Bracket

Welding Instructions for Carriage Bracket (item 10):

Locate the bracket on the back side of the upper carriage bar. Clamp in place with a "C" clamp. Protect adjacent surfaces from weld splatter with fiberglass cloth. Attach the welder ground wire to the carriage. Weld using E-7018 low hydrogen 5/32 in. (4 mm) electrodes. Use reverse polarity or

an AC welding machine set at 145-225 amps. Do not use electrodes exposed to moisture without first re-drying them at 200° F (75° C) for 2 hours. Apply a .25 in. (6 mm) fillet to both sides of the bracket holding a close arc. Let the welds slow cool.

Part No. 205856 R-1

cascade[®]

For Technical Assistance . . .

Call: 1-800-CASCADE or 503-669-6300

OR

Write: Cascade Corporation, P.O. Box 20187, Portland, OR 97220

To Order Parts . . .

Call: 513-322-1199

OR

Write: Cascade Corporation, 2501 Sheridan Ave., Springfield, OH 45505

Reusable Fittings

The hoses in the kits are long enough to connect the attachment to any lift truck. The hoses are equipped with reusable fittings so they can be cut to length. To shorten a hose, remove one of the hose end fittings using the following procedures.

IMPORTANT: Make the hose length long enough to prevent kinking when installed. Route the hoses to prevent pinching, twisting and rubbing on moving objects.

- 1 Secure the socket in a vise.

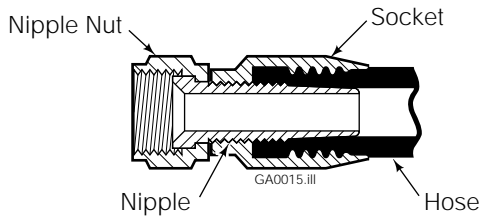

- 2 Lubricate an assembling mandrel* with hydraulic oil. Insert the mandrel into the nipple, then screw on the nipple nut. Tighten the nipple nut onto the mandrel.

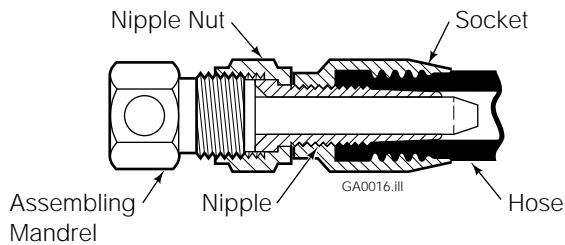

* Stratoflex Part No.: No. 6 hose-2701-9-18S; No. 8 hose-2701-12-16S

- 3 Place a wrench on the nipple nut and unthread the nipple from the socket.

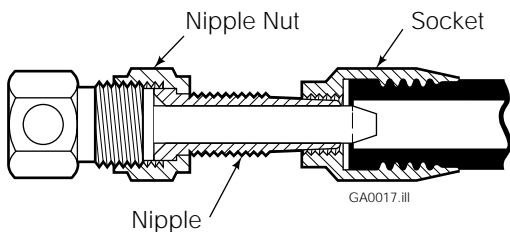

- 4 Turn the hose **clockwise** to remove it from the socket. Cut the hose to length with a fine tooth hacksaw or cutoff machine.

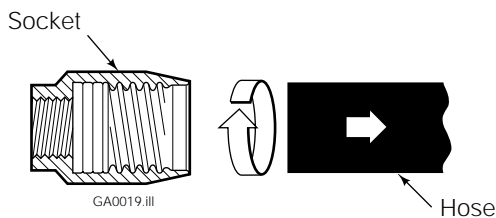

Hose Reassembly

- 1 Secure the hose in a vise and screw on the socket **counter-clockwise** until it bottoms. Unscrew the socket 1/4 turn.

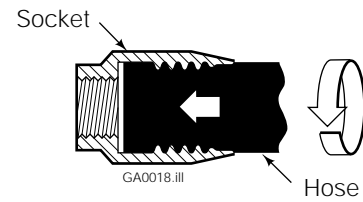

- 2 Lubricate the mandrel/nipple assembly and the inside of the hose with hydraulic oil. Insert the mandrel/nipple assembly into the hose.

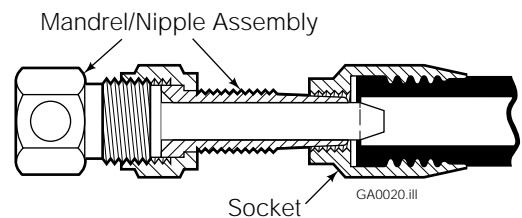

- 3 Place a wrench on the mandrel and screw the mandrel/nipple assembly into the socket. Leave 1/32 to 1/16 in. clearance between the nipple nut and socket for the nut to swivel freely.

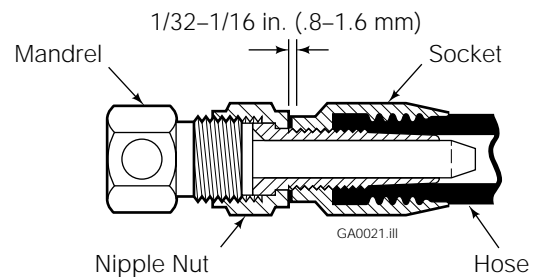

- 4 Remove the mandrel from the nipple nut. Look down through the hose to check for hose damage during assembly. Blow air through each end of the hose to remove debris. If you find internal hose damage, remove the fitting and cut away the damaged material, then reassemble.

