



# Technical Bulletin

## E-Series Fork Positioner Adjustable Fork Plate Assembly Kits

This sheet describes procedures to install new adjustable fork plate assemblies. The kits and their applications are listed below:

Fork Width	Fork Plate Assembly Kit
4 in.	202171
5 in.	202172
6 in.	202173

- 1 Remove the existing fork plates from the fork positioner.
- 2 Remove the fork weld on shims if used with previous fork plates.
- 3 Install the new fork plates over the forks with the capscrews supplied. Tighten the capscrews to a torque of 45-52 ft.-lbs. (60-70 Nm).
- 4 Center the fork in the fork plate. Install the 1/2 in. X 1 in. long setscrews in the fork plate lower holes. Screw the setscrews in until they contact the fork, then loosen 1/4 turn. The fork must be straight and centered side to side in the fork plate.
- 5 Remove any oil or dirt in the fork plate side threaded holes. Install an elastomer spring in each fork plate top hole. Push them through the hole to contact the fork.
- 6 Install the 3/4 in. X 5/8 in. long setscrews in the top fork plate holes. Tighten the setscrews to a torque of 3-6 ft.-lbs. (5-7 Nm).
- 7 Apply Loctite No. 290 to the setscrew threads. The Loctite will flow into the threads and lock the setscrews in place. Let the loctite cure for 1 hour prior to positioning the forks.

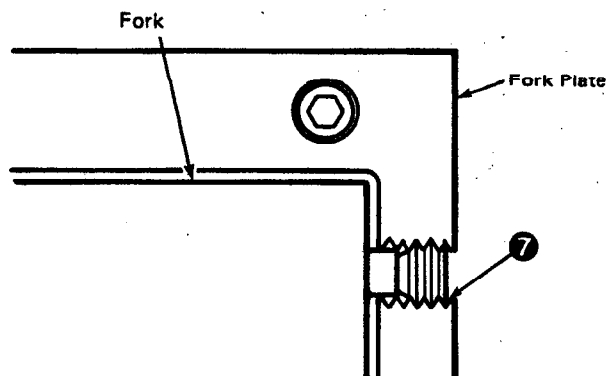

**NOTE:** This information should not be interpreted as the basis for warranty claims unless so designated.

Part No. 202170 R-1

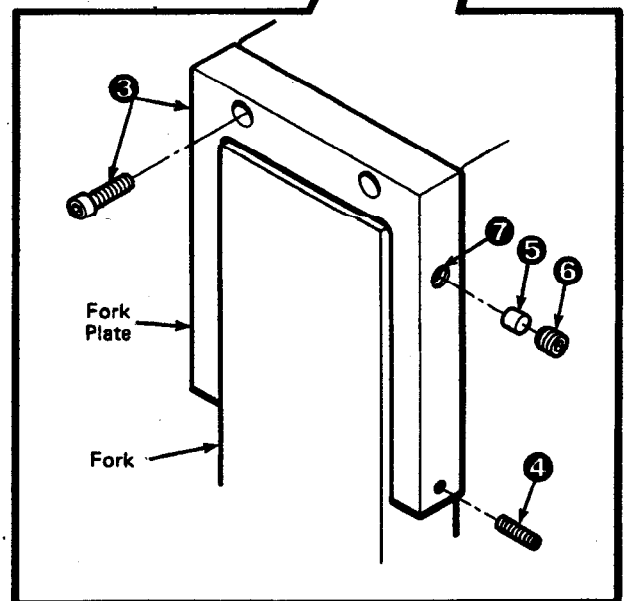
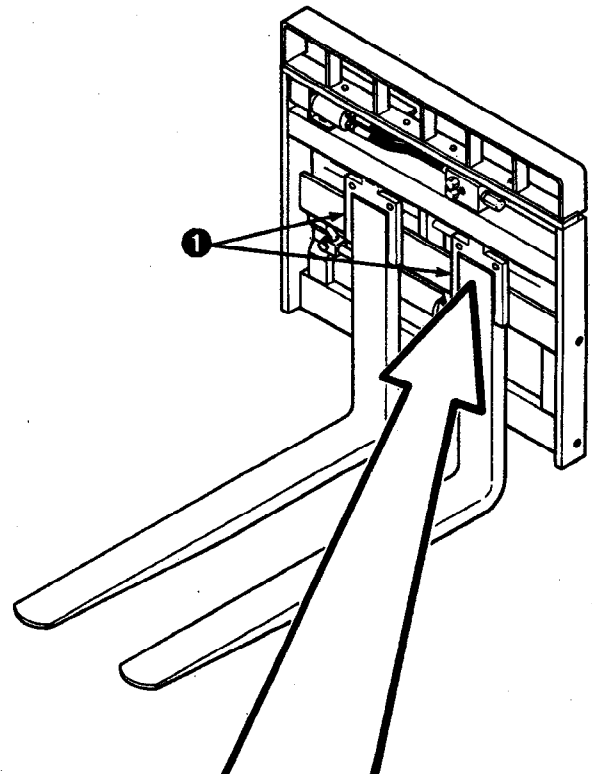

# cascade®

For Technical Assistance . . .

Call: 1-800-CASCADE or 503-669-6300

To Order Parts . . .

Call: 513-322-1199