



Installation Instructions

**Arm Overdrive Kits
6097259, 6097290,
6097293, 6097294**

This sheet provides installation instructions, cartridge adjustment and parts list for Cascade Arm Overdrive Valves. When energized, the valve blocks the tank line causing the start pressure to increase to a preset valve pressure. This valve aids with increasing arm speed and allows an attachment to have higher clamping pressure that may be needed when breaking out rolls.

INSTALLATION

NOTE: The truck must have a return-to-tank fitting installed prior to valve installation.

- 1 Determine a location and mount the valve, if required. Some applications may allow the valve to be installed directly to another valve's tank line fitting.
- 2 If needed, install a high pressure hose between the overdrive valve T IN port and the tank port of another valve. The high pressure hose must be rated at 2300 psi (160 bar) working pressure.
- 3 Install a hose from the overdrive valve T OUT port to the truck tank line fitting.
- 4 Install the pushbutton switch to the clamp control lever. Remove the control knob. Position switch on the handle in a location for comfortable thumb or index finger operation. Place the double sided tape under the switch to secure the switch in place. Using a heat gun, heat tubing to secure the switch to the handle. Remove tubing around button, as desired. Reinstall the knob. Install cable ties as needed for the wires.

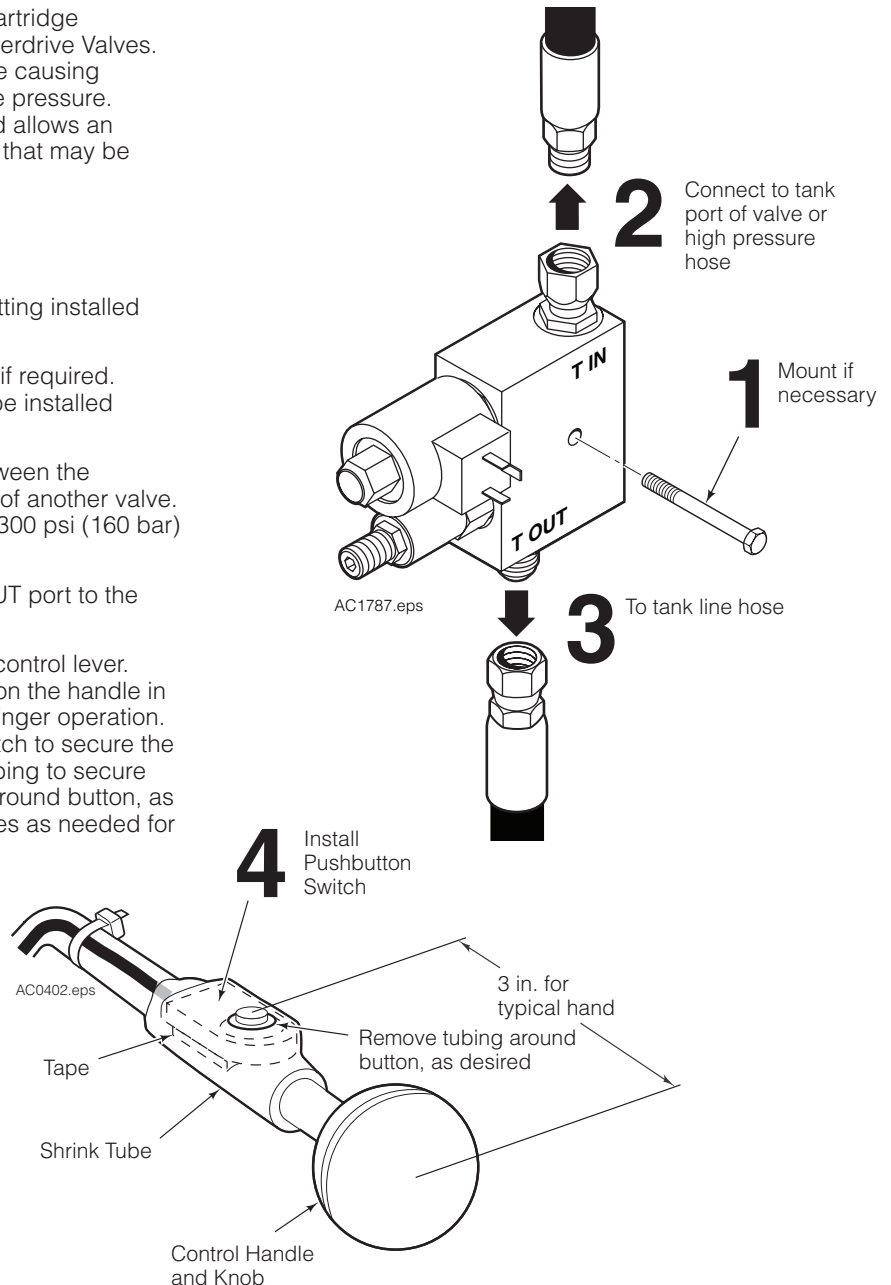

**cascade®
corporation**

For Technical Support . . .

Call: 1-800-227-2233 Fax: 1-888-329-8207
Internet: www.cascorp.com
Write: Cascade Corporation, PO Box 20187, Portland, OR 97294

To Order Parts . . .

Call: 1-888-227-2233 Fax: 1-888-329-0234
Internet: www.cascorp.com
Write: Cascade Corporation, 2501 Sheridan Ave., Springfield, OH 45505

CAUTION: Consult the Lift Truck OEM for proper + power source connection.

- 5 Disconnect the cable from the positive battery terminal. Install and route wire harness. Connect the cable ends. Connect the fused positive to a switched power source. Connect the ground wire.
- 6 Reconnect the positive battery cable to the battery.

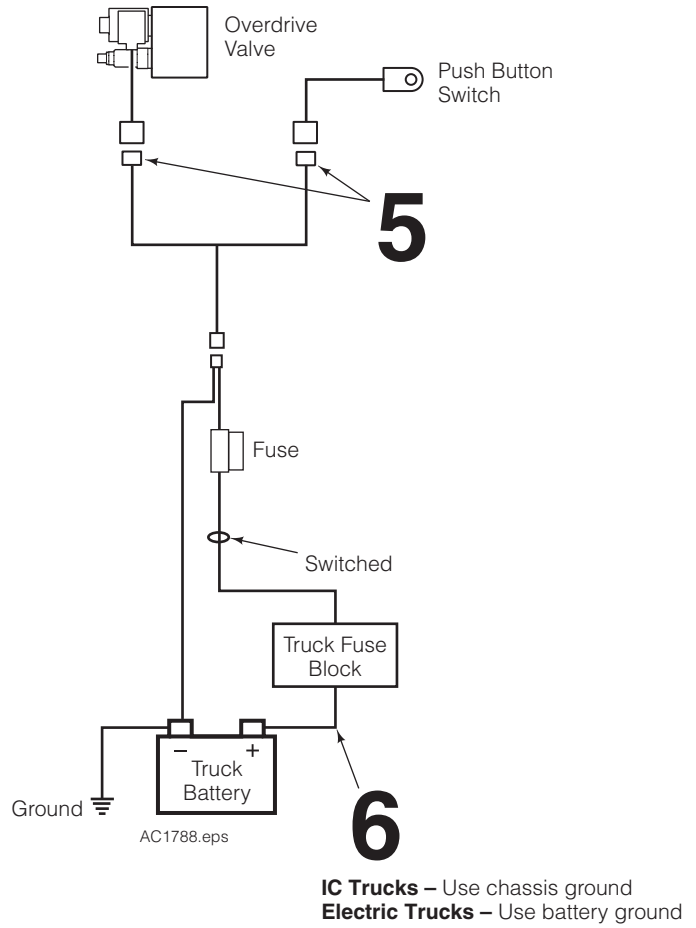

CARTRIDGE VALVE ADJUSTMENT

To set relief cartridge, install a pressure gauge in the attachment test port.

- 1 Loosen the jam nut on the relief cartridge. Adjust the relief cartridge inward (CW) to raise pressure or outward (CCW) to lower the pressure.
- 2 While clamping, energize and hold the pushbutton. Check gauge pressure. Readjust as required. Tighten jam nut.

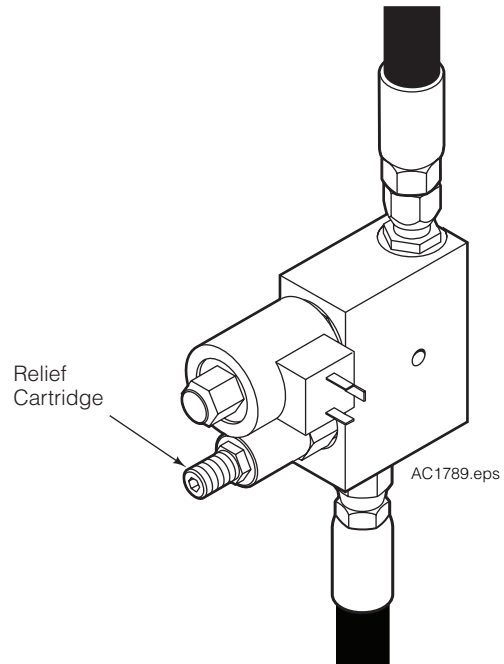

Parts – Arm Overdrive Kits

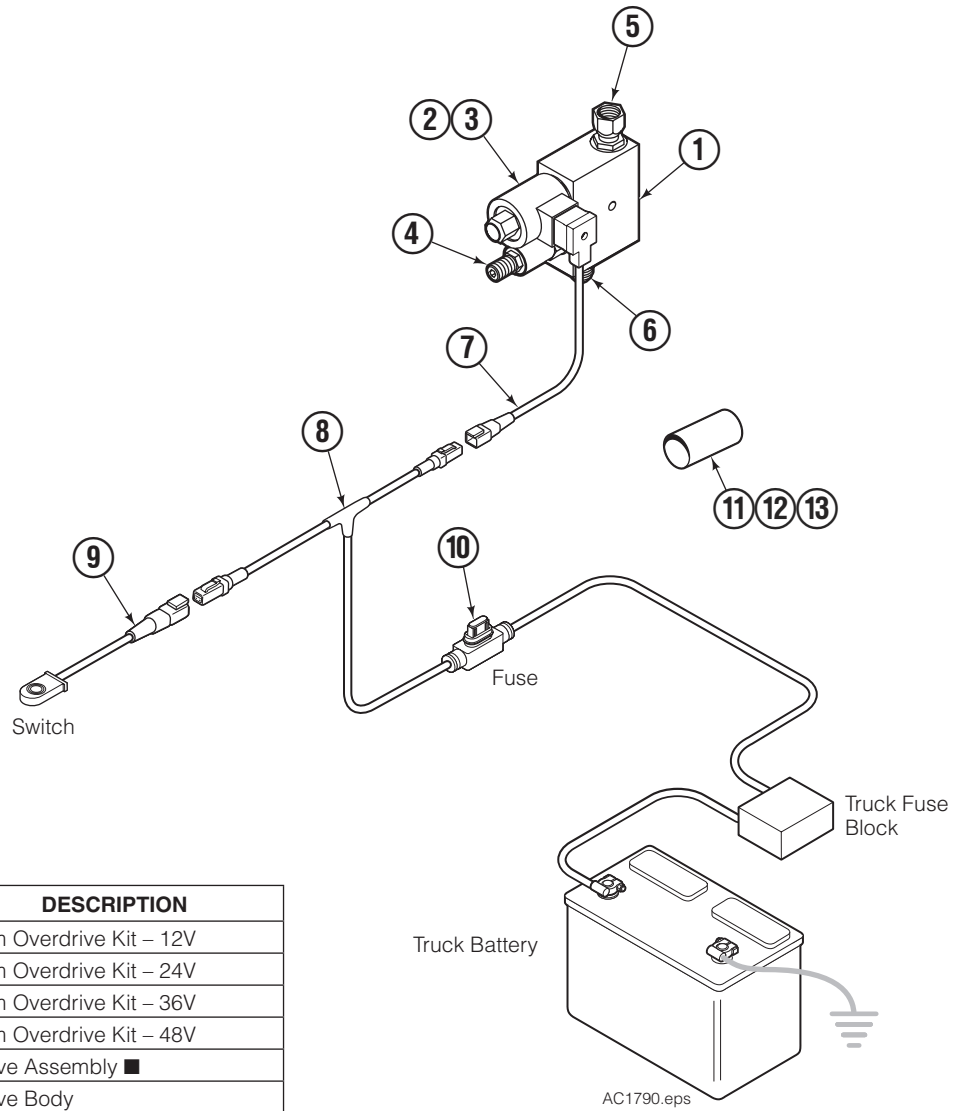

REF	QTY	PART NO.	DESCRIPTION
		6097259	Arm Overdrive Kit – 12V
		6097290	Arm Overdrive Kit – 24V
		6097293	Arm Overdrive Kit – 36V
		6097294	Arm Overdrive Kit – 48V
		6097150	Valve Assembly ■
1	1	6097150	Valve Body
2	1	6014287	Coil – 12V
		6018032	Coil – 24V
		6018036	Coil – 36V
		6018038	Coil – 48V
3	1	6056977	Solenoid Cartridge
4	1	6097200	Relief Valve Cartridge
5	1	6043723	Fitting, 8-8
6	1	601377	Fitting, 8-8
7	1	6097235	Solenoid Connector
8	1	6097225	Wire Harness ●
9	1	6097238	Switch Assembly
10	1	221720	Fuse, ATC type 5 Amp
11	1	6001641	Shrink Tube, 1.0 in. diameter
12	1	6026933	Shrink Tube, 1.5 in. diameter
13	1	6026934	Shrink Tube, 2.0 in. diameter
◆	1	6014987	Adhesive Tape

- Includes item 1 and 3–6.
- Includes items 7 & 9.
- ◆ Not shown.

Do you have questions you need answered right now?

Call your nearest Cascade Service Department.
Visit us online at www.cascorp.com

AMERICAS

**Cascade Corporation
U.S. Headquarters**
2201 NE 201st
Fairview, OR 97024-9718
Tel: 800-CASCADE (227-2233)
Fax: 888-329-8207

Cascade Canada Inc.
5570 Timberlea Blvd.
Mississauga, Ontario
Canada L4W-4M6
Tel: 905-629-7777
Fax: 905-629-7785

Cascade do Brasil
Rua João Guerra, 134
Macuco, Santos - SP
Brasil 11015-130
Tel: 55-13-2105-8800
Fax: 55-13-2105-8899

EUROPE-AFRICA

**Cascade Italia S.R.L.
European Headquarters**
Via Dell'Artigianato 1
37050 Vago di Lavagno (VR)
Italy
Tel: 39-045-8989111
Fax: 39-045-8989160

Cascade (Africa) Pty. Ltd.
PO Box 625, Isando 1600
60A Steel Road
Sparton, Kempton Park
South Africa
Tel: 27-11-975-9240
Fax: 27-11-394-1147

ASIA-PACIFIC

Cascade Japan Ltd.
2-23, 2-Chome,
Kukuchi Nishimachi
Amagasaki, Hyogo
Japan, 661-0978
Tel: 81-6-6420-9771
Fax: 81-6-6420-9777

Cascade Korea
121B 9L Namdong Ind.
Complex, 691-8 Gojan-Dong
Namdong-Ku
Inchon, Korea
Tel: +82-32-821-2051
Fax: +82-32-821-2055

Cascade-Xiamen
No. 668 Yangguang Rd.
Xinyang Industrial Zone
Haicang, Xiamen City
Fujian Province
P.R. China 361026
Tel: 86-592-651-2500
Fax: 86-592-651-2571

**Cascade India Material
Handling Private Limited**
No 34, Global Trade Centre
1/1 Rambaugh Colony
Lal Bahadur Shastri Road,
Navi Peth, Pune 411 030
(Maharashtra) India
Phone: +91 020 2432 5490
Fax: +91 020 2433 0881

Cascade Australia Pty. Ltd.
1445 Ipswich Road
Rocklea, QLD 4107
Australia
Tel: 1-800-227-223
Fax: +61 7 3373-7333

Cascade New Zealand
15 Ra Ora Drive
East Tamaki, Auckland
New Zealand
Tel: +64-9-273-9136
Fax: +64-9-273-9137

**Sunstream Industries
Pte. Ltd.**
18 Tuas South Street 5
Singapore 637796
Tel: +65-6795-7555
Fax: +65-6863-1368

