



# **INSTALLATION INSTRUCTIONS**

---

## ***E-Series***

### ***Fork Positioner***

***Manual Number 688262 R-1***

**cascade<sup>®</sup>**  
Cascade is a Registered Trademark of Cascade Corporation



# T RUCK REQUIREMENTS

## Truck Relief Setting

2000 psi (140) bar – Recommended  
2300 psi (160) bar – Maximum

## Truck Flow Volume

3 GPM (11 L/min.) – Minimum  
8 GPM (30 L/min.) – Recommended  
10 GPM (37 L/min.) – Maximum

Mounting	Dimension A-ITA (ISO)	
	Minimum	Maximum
Class II	14.96 in. (380.0mm)	15.00 in. (381.0mm)
Class III	18.68 in. (474.5mm)	18.74 in. (476.0mm)

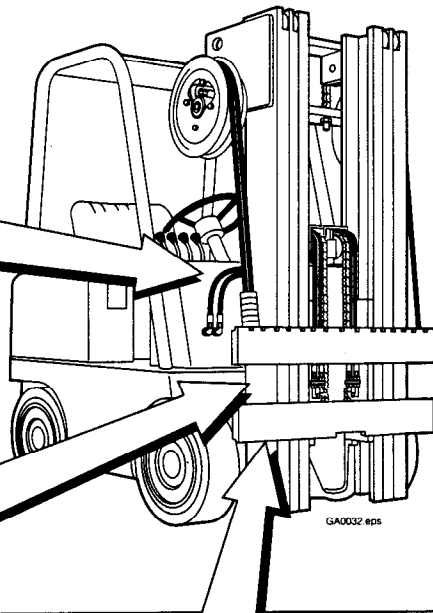

Clean carriage bars  
Inspect for damaged notches

# H YDRAULIC SUPPLY

The attachment will require one of the following hydraulic supply arrangements. All hoses and fittings should be at least No. 6 with 9/32 in. (7 mm) minimum I.D. Refer to Hose and Cable Reel Selection Guide Form 4099 to select the correct hose reels for the mast and truck.

## RECOMMENDED HYDRAULIC SUPPLY OPTIONS

### Fork Positioner with Standard Valve

#### Non-Sideshifting

- A Mast Single Internal Reeving
- OR
- B RH THINLINE™ 2-Port Hose Reel Group

#### Sideshifting

- A Mast Double Internal Reeving
- OR
- A and B RH THINLINE™ 2-Port Hose Reel Group and Mast Single Internal Reeving
- OR
- B and C RH and LH THINLINE™ 2-Port Hose Reel Groups

### Fork Positioner with Sequence Valve

- A Mast Single Internal Reeving
- OR
- B RH THINLINE™ 2-Port Hose Reel Group

### Fork Positioner with Solenoid Valve

- A and C RH Cable Reel Supply and Mast Single Internal Reeving
- OR
- B RH 6-N-1 Cable/Hose Reel Group

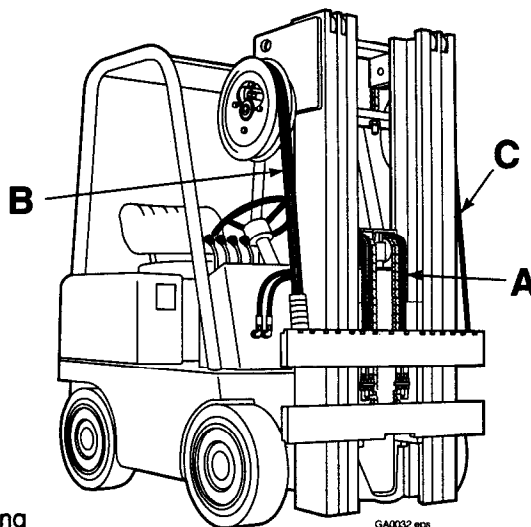

# INSTALLATION

## 1 Attach overhead hoist

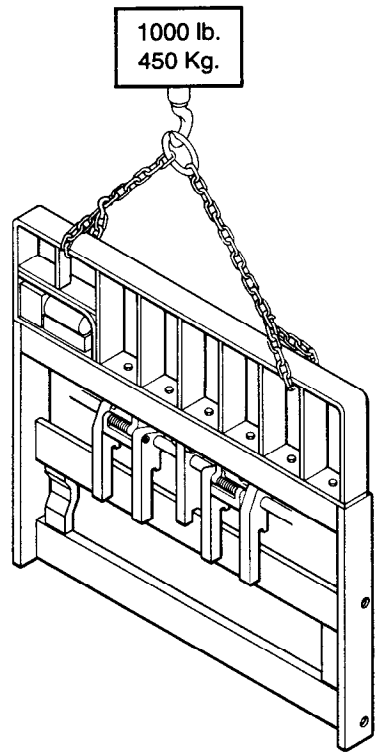

## 2 Remove lower hooks

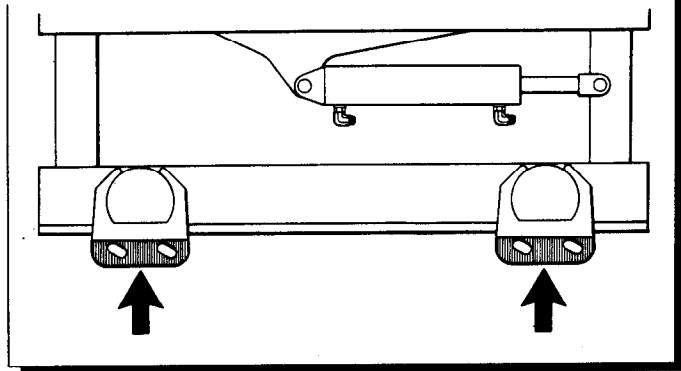

## 3 Mount on lift truck

55E--.60-.66 in. (15-17 mm)  
60E/100E--.72-.78 in. (18-20 mm)

55E--.32-.36 in. (7-9 mm)  
60E/100E--.40-.44 in. (9-11 mm)

Truck carriage  
center notch

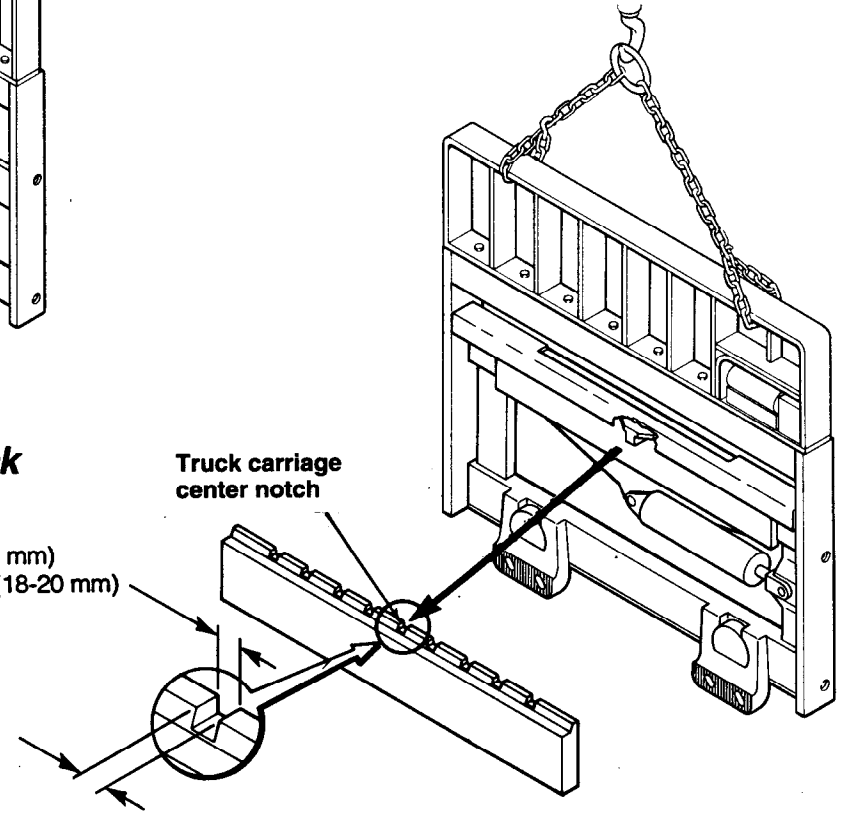

## 4 Install lower hooks

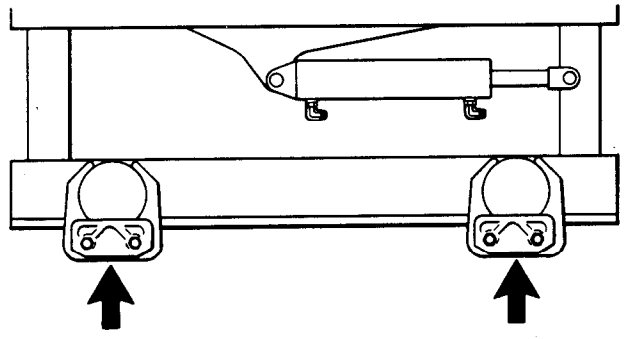

.06 in. (1.5 mm)  
.13 in. (3.0 mm)

Tighten to  
115-125 ft.-lbs.  
(155-170 Nm)

# 1 INSTALLATION

## 5 Install forks

- A Detach frame from carriage
- B Remove fork lock pins
- C Install forks

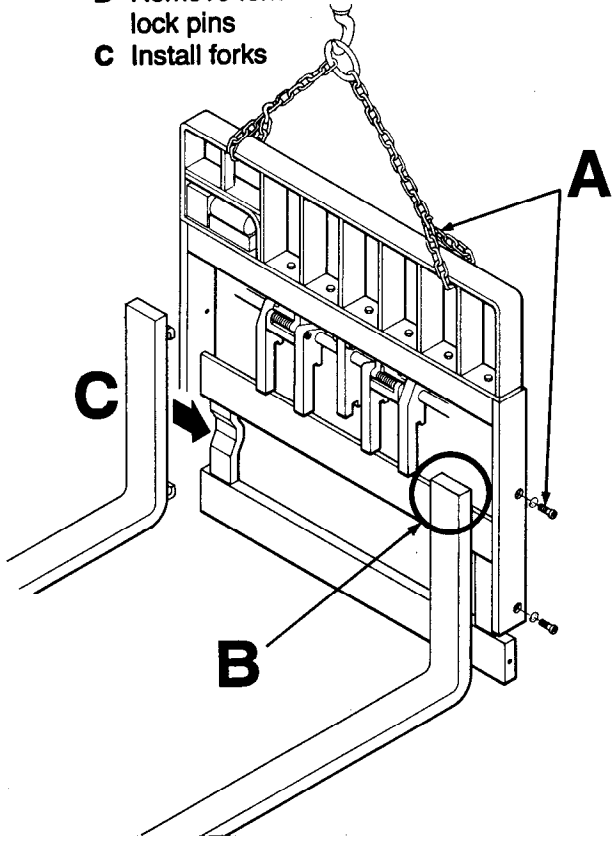

## 6 Adjust fork carriers

- A Position forks and carriers
- B Adjust carrier width
- C Attach frame to carriage

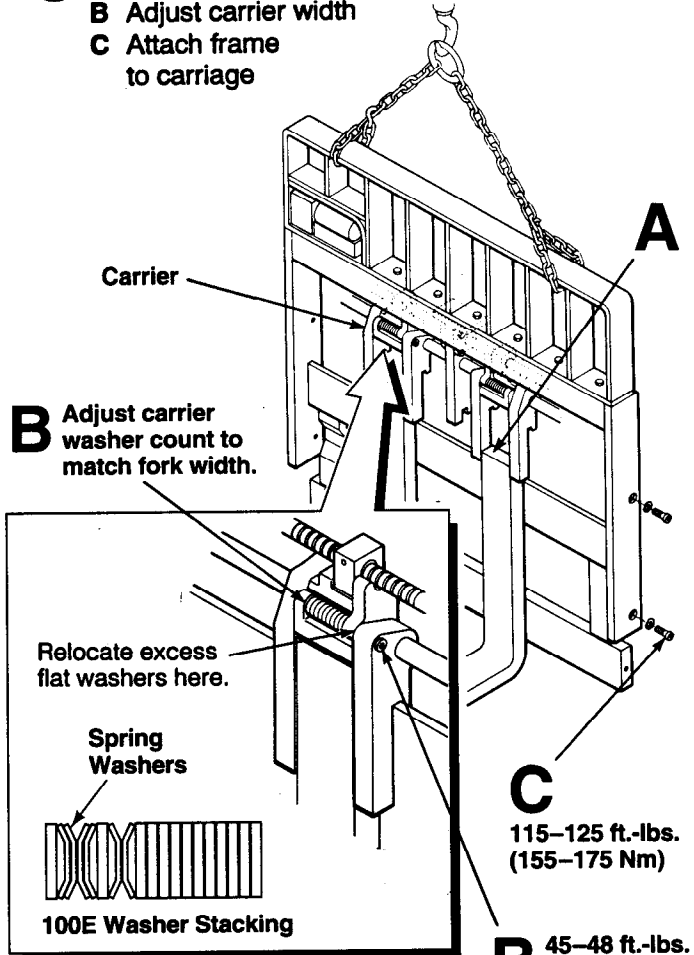

**C** 115–125 ft.-lbs.  
(155–175 Nm)

**B** 45–48 ft.-lbs.  
(60–65 Nm)

## 7 Install solenoid control knob – Solenoid equipped units.

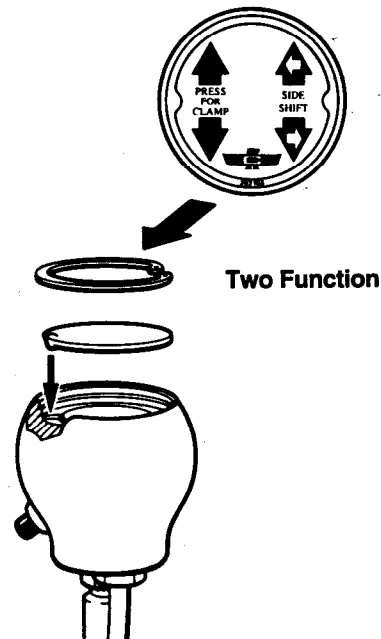
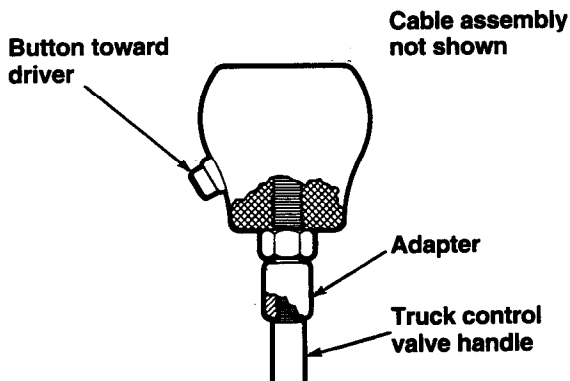

# INSTALLATION

## 8 Install wiring – Solenoid equipped units.

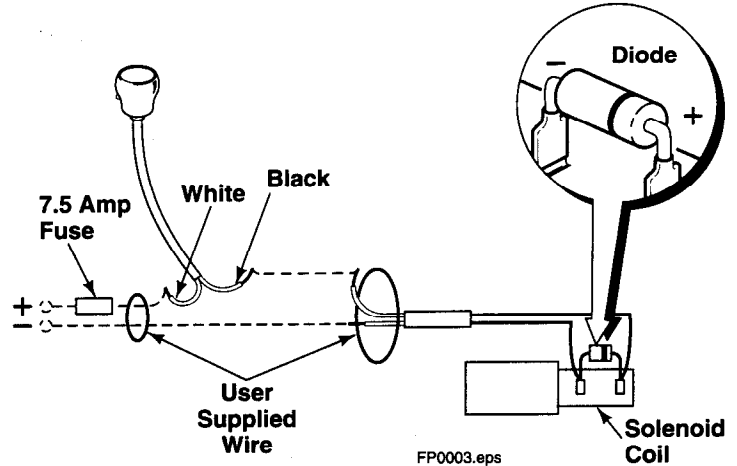
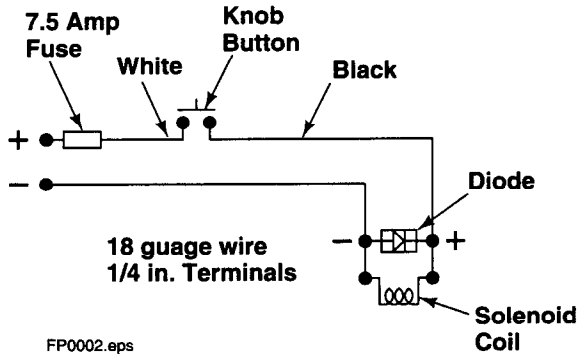

## 9 Flush hydraulic supply hoses

- A Install hoses
- B Operate auxiliary valves (both directions)
- C Remove hoses

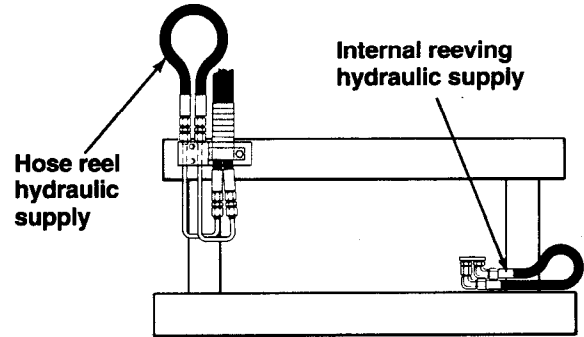

## 10 Install hoses

### FORK POSITIONER WITH STANDARD VALVE

#### Double Internal Reeving Hydraulic Supply

Installation Kits  
 685480 and 689175 (Non-SS)  
 685480 and 689174 (SS)

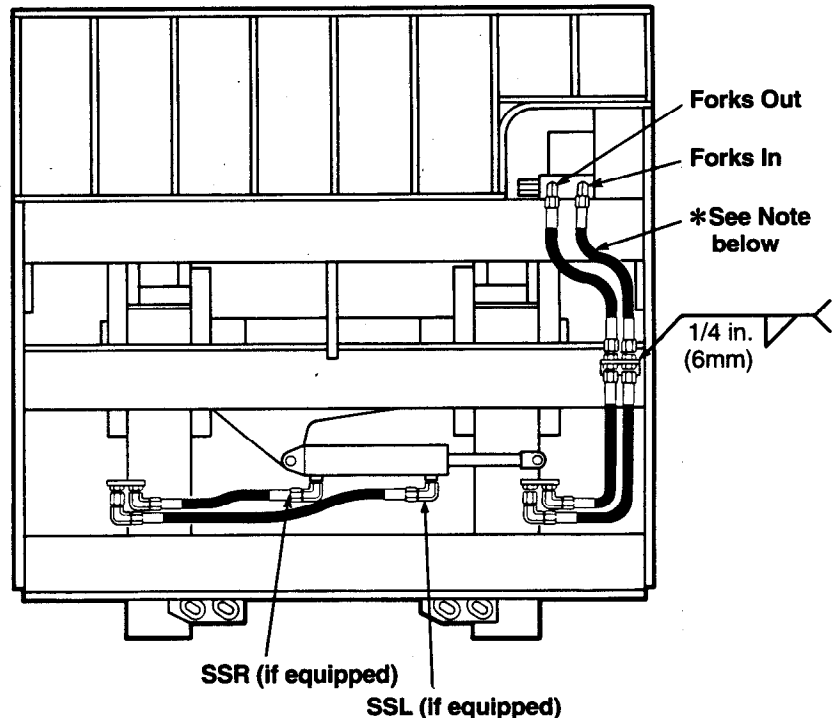

\* Allow length for 4 in. sideshift in each direction

## 10 Install hoses

### FORK POSITIONER WITH SEQUENCE VALVE

Hose Reel Hydraulic Supply  
Installation Kit 206648

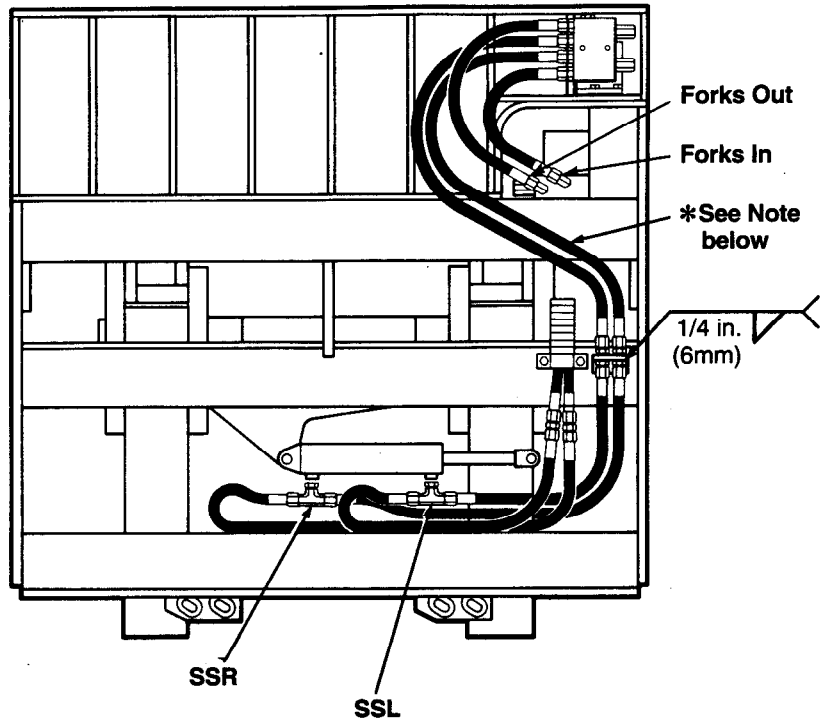

Internal Reeving Hydraulic Supply  
Installation Kit 689175

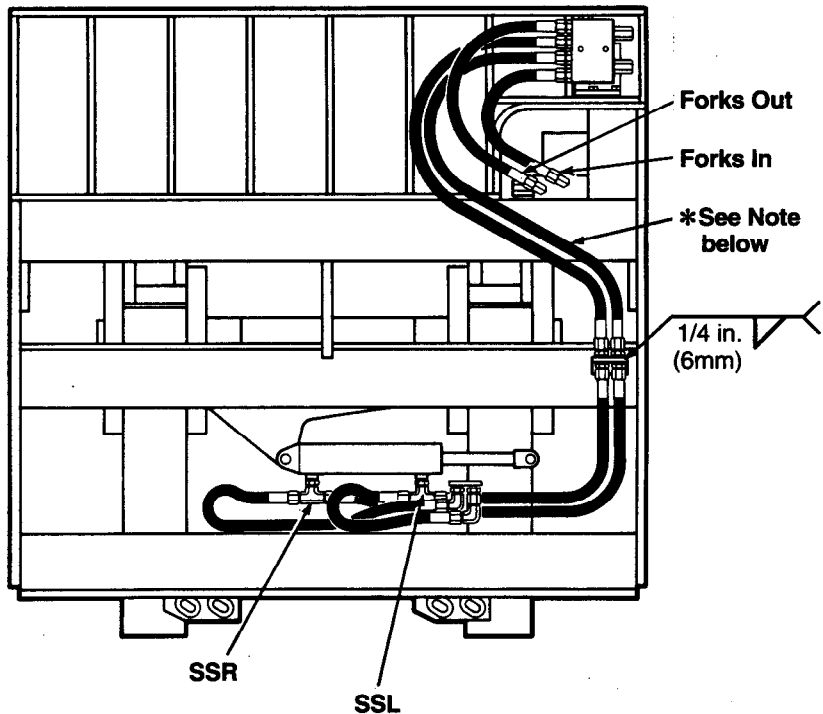

\* Allow length for 4 in. sideshift in each direction

## 10 *Install hoses*

### **FORK POSITIONER WITH SOLENOID VALVE**

**Cable Reel and Internal Reeving Hydraulic Supply**

**Installation Kits  
685480 and  
689175**

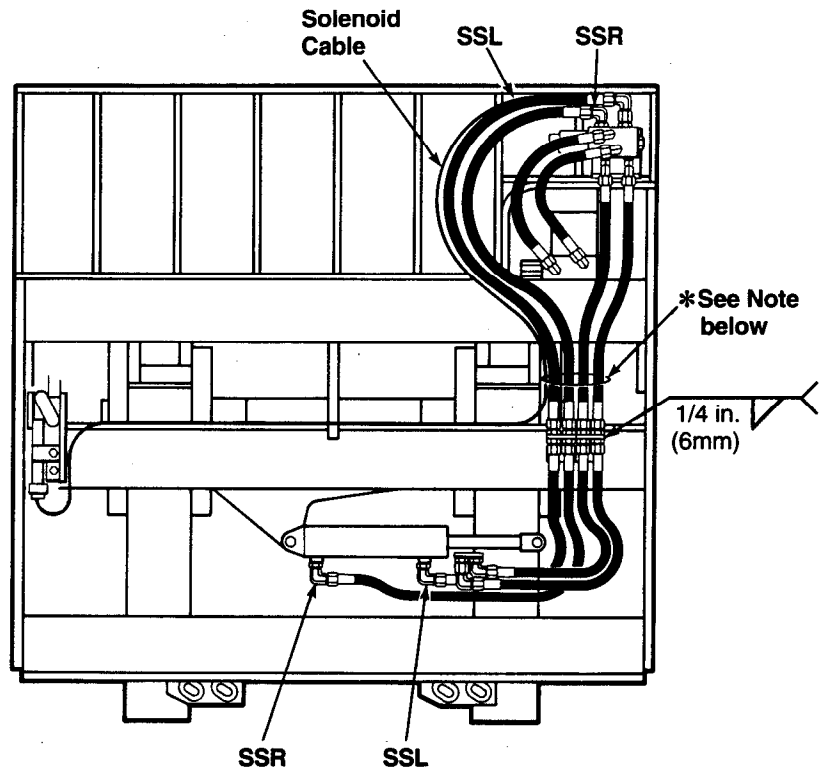

**6-N-1 Cable-Hose Reel Hydraulic Supply**

**Installation Kits  
685480 and  
(2) 674371 Tubes**

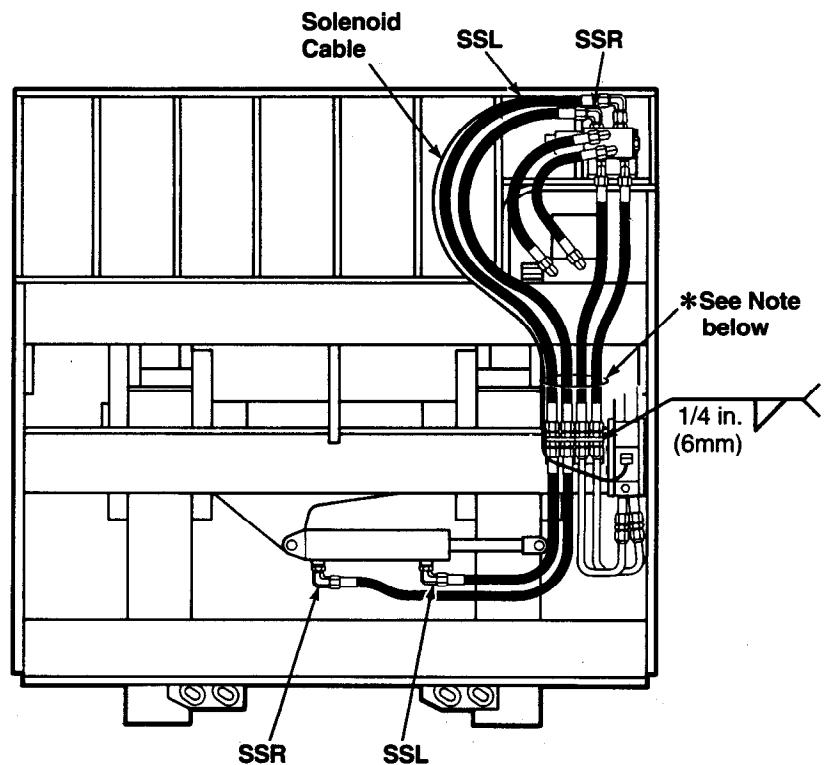

**\* Allow length for 4 in. sideshift in each direction**

## 11 Auxiliary valve functions

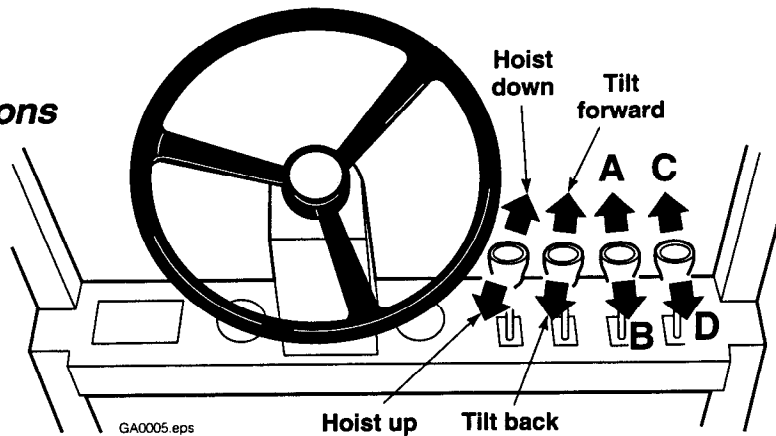

### FORK POSITIONER WITH STANDARD VALVE

- A Sideshift Left
- B Sideshift Right
- C Forks Out
- D Forks In

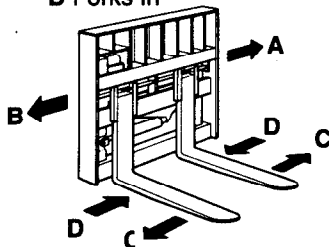

### FORK POSITIONER WITH SEQUENCE VALVE

- A Sideshift Left – Forks Out
- B Sideshift Right – Forks In

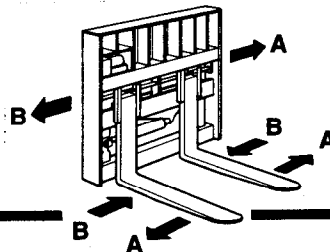

### FORK POSITIONER WITH SOLENOID

- A Sideshift Left
- A Forks Out (press knob button)
- B Sideshift Right
- B Forks In (press knob button)

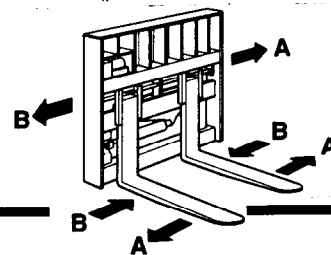

## 12 Lubrication points – 500 hours

- Lubricate grease fittings and Acme threads with chassis grease.
- Lubricate the shaded areas on the fork bars with Slip Plate (Slip It) No. 8035 lubricant–Cascade part no. 599489.

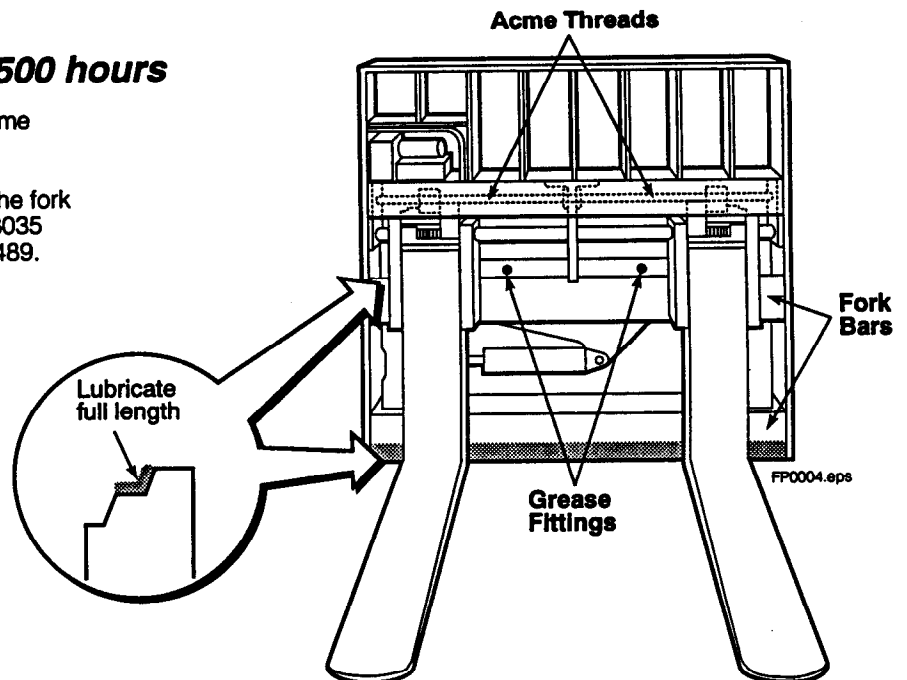

Do you have questions you need answered right now?

Toll Free Directline  
800-CAS-CADE (227-2233)