



Installation Instructions

Sideshifter Cylinder Service Kit 6019928

This sheet provides instructions to install Cylinder Seal Kit 6019928.



WARNING: Before removing hoses or hydraulic components, relieve pressure in the attachment hydraulic system. Turn the truck off and move the truck control handle several times in both directions.

- 1 Disconnect hoses from the cylinder and tag for reassembly. Plug the hose ends and cap the cylinder fittings.
- 2 Remove the cotter pins and clevis pins from the carriage mounting yokes and remove the cylinder.
- 3 Inspect the cylinder shell and rod ends for damage that could impair performance or cause leaks under pressure. If damage is found, replace the complete cylinder assembly. **NOTE:** The internal piston seals are not serviceable.
- 4 Inspect the carriage/cylinder mounting yokes for damage. If damage is found, repair or replace the frame.
- 5 For reassembly after servicing the cylinder, reverse the above procedures with the following exceptions:
 - Make sure the roll pin is installed on the cylinder to prevent cylinder rotation.
 - Install the cylinder using new clevis pins and cotter pins included in the service kit.

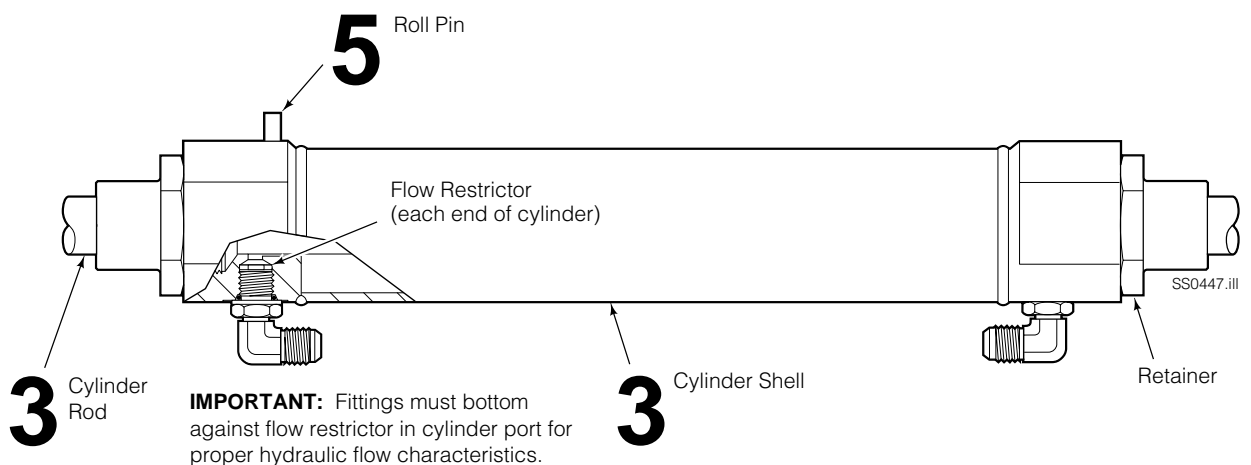
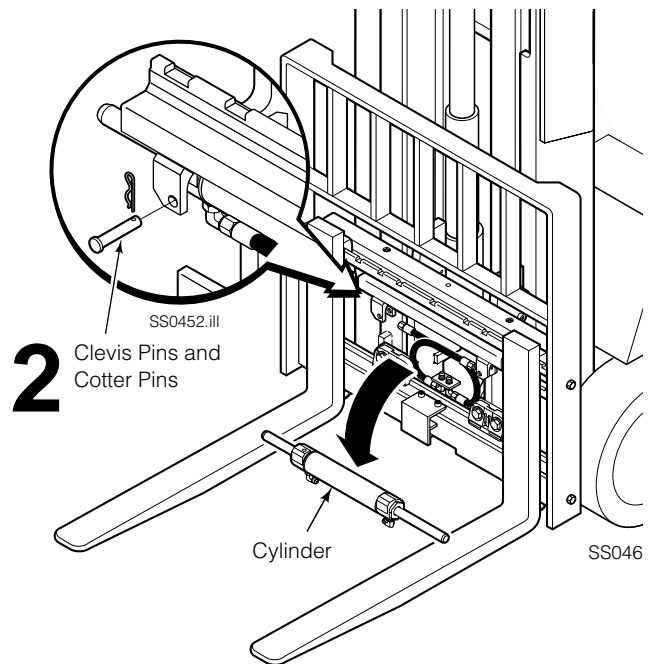

cascade[®]
corporation

For Technical Support . . .

Call: 1-800-227-2233

OR

Write: Cascade Corporation, P.O. Box 20187, Portland, OR 97294

To Order Parts . . .

Call: 1-888-227-2233

OR

Write: Cascade Corporation, 2501 Sheridan Ave., Springfield, OH 45505

Cylinder Service

NOTE: The retainers are the only field serviceable parts on the cylinder and are supplied with the seals already loaded. The cylinder must be removed from the sideshifter frame to replace the seals.

- 1 Clamp the end of the cylinder in a soft-jawed vise.
CAUTION: Do not clamp on the cylinder shell. Clamp on the ends of the cylinder only.
- 2 Unthread retainer carrier from each end of the cylinder and remove from the cylinder rod.

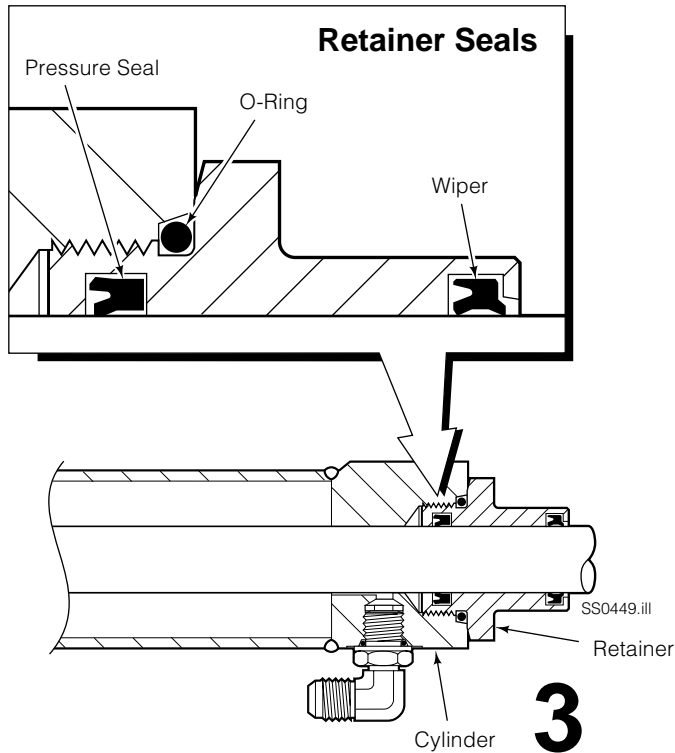

- 3 For reassembly, reverse the above procedures with the following exceptions:
 - Remove any sharp edges on the cylinder rod ends with emery cloth and clean with solvent.
 - Make sure the seals and O-ring are seated in the retainer grooves. Apply a thick film of petroleum jelly to the retainer interior bore. Carefully slide the retainer onto the cylinder rod and screw into the cylinder. Tighten the retainer to a torque of 240 ft.-lbs. (325 Nm).

