



# Technical Bulletin

## 33E Carton Clamp Service A) Replace Main Valve Cartridges, B) Tighten Baseplate Capscrews

This sheet describes mandatory service for the Cascade Model 33E Carton Clamp:

- A) Remove and replace the check valve cartridges and the flow divider cartridge in the Clamp's main hydraulic valve using the parts contained in Service Kit 215767.
- B) Tighten the capscrews that fasten the cylinder/bearing ways and the bumper to the baseplate.

### A) Replace Main Valve Cartridges



**WARNING:** Failure to replace the existing cartridges may result in less than full hydraulic pressure being developed during load handling, possibly resulting in serious injury or property damage.

- 1 Lower the Clamp to the floor. Locate the Clamp's main hydraulic valve.



**WARNING:** Before servicing hydraulic components, relieve pressure in the hydraulic system. Position arms to midstroke, turn the truck off and actuate the truck auxiliary control valves several times in both directions.

- 2 Remove the one (1) existing Flow Divider/Combiner cartridge from the main valve and replace with the new cartridge supplied in the kit. Tighten the cartridge to 50 ft.-lbs. (70 Nm).
- 3 Remove the three (3) existing Check Valve cartridges and pistons from the main valve. Replace with the new cartridges and pistons supplied in the kit. Tighten the cartridges to 50 ft.-lbs. (70 Nm).

**IMPORTANT: Discard existing check valve pistons.** Use needle-nosed pliers as required to remove the pistons from the valve body and replace with new pistons.

(continued on back)

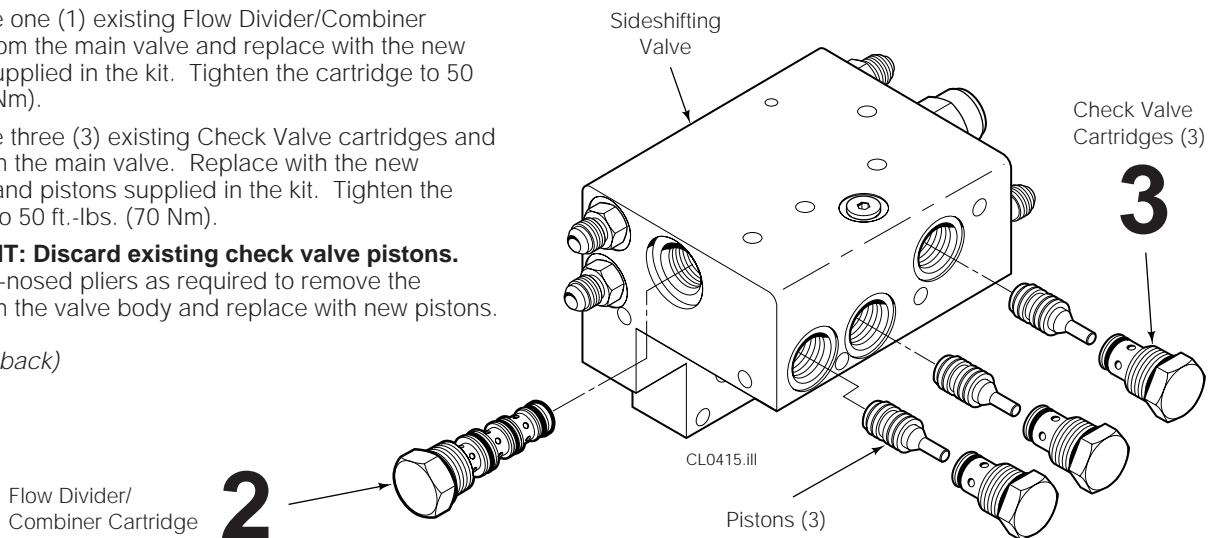
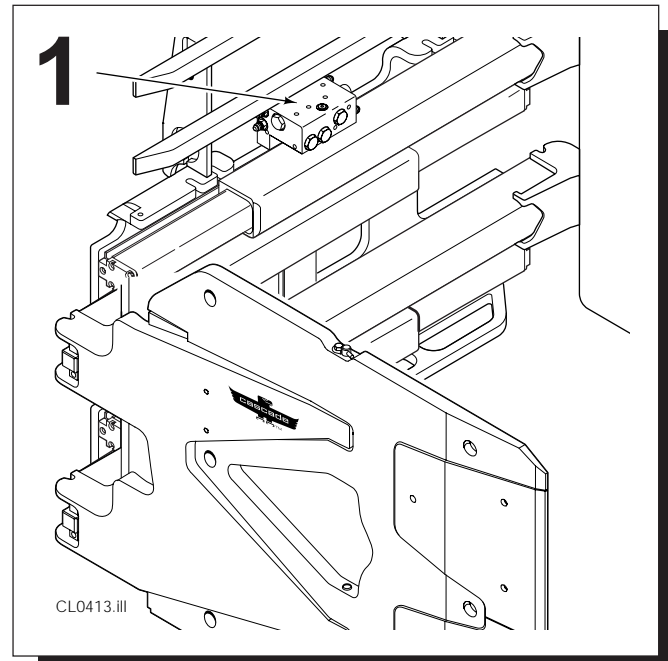

**NOTE:** This information should not be interpreted as the basis for warranty claims unless so designated.

# cascade®

For Technical Assistance and to Order Parts . . .

Call: 1-800-CASCADE (227-2233) or 503-669-6300

FAX: 503-669-6367

Write: Cascade Corporation, PO Box 20187, Portland, OR 97220

## B) Tighten Baseplate Capscrews

**NOTE:** The Carton Clamp must be removed from the truck to perform this service procedure.

- 1 Position the Clamp's arms to the width of the frame.
- 2 Disconnect and plug the hydraulic supply hoses to the Clamp. Tag hoses for reassembly.
- 3 Disconnect the lower hooks:
  - Quick-Change Hooks** – Remove the locking pins and drop the hooks into the unlocked position. Replace the pins in the lower holes. For reassembly, remove the pins and slide the hooks up to the locked position. Replace the pins in the top holes.
  - Bolt-On Hooks** – Remove the capscrews and mounting hooks. For reassembly, tighten the capscrews to 165 ft.-lbs. (225 Nm).
- 4 Lower the Clamp onto a pallet. Tilt the mast forward and lower the carriage to disengage the upper hooks.
- 5 Check the torque on each cylinder/bearing way-to-baseplate capscrew and each bumper-to-baseplate capscrew and tighten if necessary to 75 ft.-lbs. (100 Nm).
- 6 For Clamp installation, reverse the above procedures.
- 7 Test the Clamp through several cycles. First test the Clamp empty to bleed any air trapped in the system to the truck tank. Then test the Clamp with a load to be sure it operates correctly before returning to the job.

**Stay clear of the load while testing. Do not raise the load more than 4 in. (10 cm) off the floor while testing clamp and sideshift functions.**

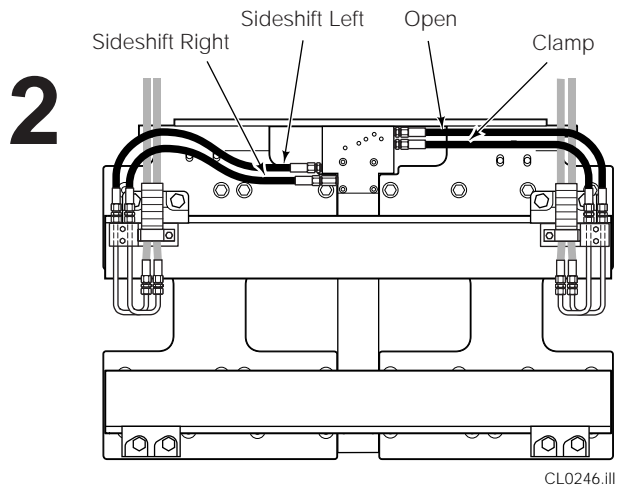

CL0246.III

- 4 Lower the Clamp onto a pallet. Tilt the mast forward and lower the carriage to disengage the upper hooks.
- 5 Check the torque on each cylinder/bearing way-to-baseplate capscrew and each bumper-to-baseplate capscrew and tighten if necessary to 75 ft.-lbs. (100 Nm).
- 6 For Clamp installation, reverse the above procedures.
- 7 Test the Clamp through several cycles. First test the Clamp empty to bleed any air trapped in the system to the truck tank. Then test the Clamp with a load to be sure it operates correctly before returning to the job.

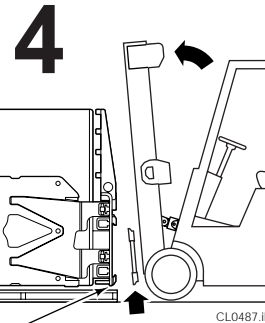

CL0487.III

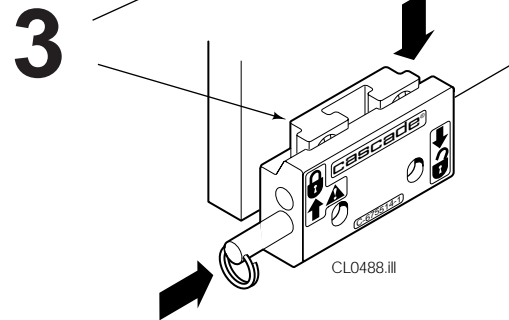

CL0488.III

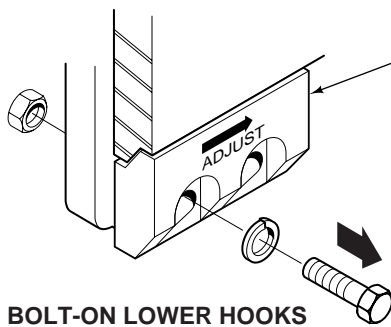

**BOLT-ON LOWER HOOKS**

**QUICK-CHANGE LOWER HOOKS**

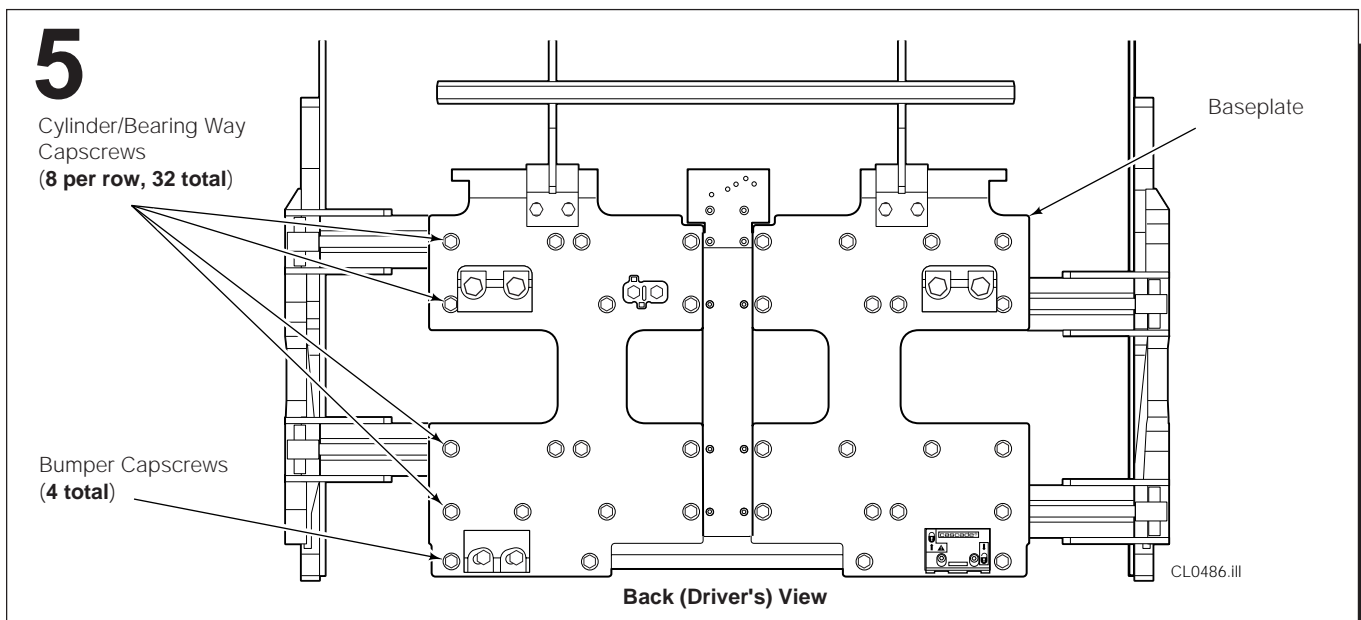

CL0486.III