



# Service Manual

---

## 30E Rotator

---

Serial Numbers 680089 through 680094

Manual Number 684597 Rev.0

---

**cascade**<sup>®</sup>

Cascade is a Registered Trademark of Cascade Corporation

# Contents

---

	Page
<b>INTRODUCTION, Section 1</b>	1
Special Definitions	1
<b>INSTALLATION INSTRUCTIONS, Section 2</b>	1
Truck Requirements	1
Installation	2
Truck Preparation	2
Attachment Installation	2
Fork Middle Hook Installation	5
How to Install and Position Forks	5
Prior to Operation	6
<b>PERIODIC MAINTENANCE, Section 3</b>	7
<b>TROUBLESHOOTING, Section 4</b>	8
General Procedures	8
Plumbing	10
Hosing Diagram	10
Circuit Schematic	10
Rotator Troubleshooting	11
Supply Circuit Test	11
Rotation without a Load	11
Rotation with a Load	12
<b>SERVICE, Section 5</b>	13
Attachment Removal	13
Drive Group	14
Drive Group Removal and Installation	14
Drive Group Disassembly and Service	15
Drive Group Reassembly	16
Drive Motor	18
Drive Motor Removal and Installation	18
Drive Motor Disassembly	19
Drive Motor Inspection	20
Drive Motor Reassembly	21
Base Unit	22
Bearing Assembly Removal and Installation	22
<b>SPECIFICATIONS, Section 6</b>	23
Hydraulics	23
Truck Carriage	23
Torque Values	24
Determining Load Torque Requirements	25

# 1 Introduction

This manual provides the installation instructions, periodic maintenance requirements, troubleshooting procedures and service guides for 30E Rotators. Note that all specifications are shown in US and (Metric) units where applicable.

## 1.1 Special Definitions

### ▲ WARNING

A statement preceded by **▲ WARNING** is information that should be acted upon to prevent **bodily injury**. A **WARNING** is always inside a ruled box.

### CAUTION

A statement preceded by **CAUTION** is information that should be acted upon to prevent machine damage.

### IMPORTANT

A statement preceded by **IMPORTANT** is information that possesses special significance.

### NOTE

A statement preceded by **NOTE** is information that is handy to know and may make your job easier.

# 2 Installation Instructions



**WARNING:** Rated capacity of the truck/attachment combination is a responsibility of the original truck manufacturer and may be less than that shown on the attachment nameplate. Consult the truck nameplate.

## 2.1

### Truck Requirements

- Truck Relief Valve Setting:  
2300 psi (160 bar), maximum.  
2000 psi (140 bar), recommended.
- Hydraulic flow should fall within the volume range shown in the chart.
- The truck hydraulic system must supply hydraulic oil to the attachment that meets the specifications shown in the chart.
- Recommended hose and fitting size:  
No. 6 with fitting orifices of 9/32 in. (7 mm).
- The truck carriage must conform to ISO dimensional standard 2328, equivalent to Industrial Truck Association (ITA) dimensions shown in Section 6.1-2.
- Make sure the truck carriage is clean and the notches are undamaged.
- In order to conform to industry standard practice, the hoses should be connected to the truck auxiliary valve as indicated by the chart in Section 6.1-1.

### Hydraulic Specifications

<b>Pressure – Maximum</b>	2300 psi (160 bar)
<b>Recommended</b>	2000 psi (140 bar)
<b>Flow – Minimum★</b>	5 GPM (19L/min)
<b>Recommended</b>	7 GPM (26L/min)
<b>Maximum‡</b>	10 GPM (38L/min)
<b>Supply Hose and Fitting Size</b>	No. 6
<b>Minimum Orifice Size</b>	9/32 in. (7mm)

★ Flow less than minimum will result in a rotate speed less than 2 rpm.

‡ Flow greater than maximum can result in excessive heating, reduced system performance and short hydraulic system life.

**Hydraulic Oil** – Cascade attachments are compatible with SAE 10W petroleum base oil per Mil. Spec. MIL-0-5606 or MIL-0-2104B.

Use of synthetic or aqueous base hydraulic oil is not recommended. Contact Cascade if fire resistant hydraulic oil must be used.

27781-198/6

## 2.2 Installation

### 2.2-1 Truck Preparation

The following preparation should be performed prior to attachment installation.

The 30E Rotator requires one hydraulic supply circuit over the mast. No. 6 size hosing (minimum) is required for the rotate function to maximize speed and minimize restriction. A Cascade THINLINE™ Hose Reel provides an economical and efficient means of supplying hydraulics over the mast. Refer to Hose and Cable Reel Selection Guide Form 4099 to select the correct hose reel for the truck and mast. If the truck is equipped with mast single internal hose reeving, then a Hose Reel will not be required.

### 2.2-2 Attachment Installation



**WARNING:** Make sure the overhead hoist has a rated capacity of at least 1000 lbs. (450 kg).

- 1 Attach overhead hoist hooks to the frame in the location shown. Lift the attachment and position upright. Remove the bolt-on lower hooks (if equipped).
- 2 **Clamps with Quick Change Lower Hooks-**
  - a. Install the guides to the baseplate mounting holes with the guide hole offset in the upward position - 5/8 in. (16 mm) from top of guide to hole center. Tighten the capscrews to a torque of 110-120 ft.-lbs. (150-165 Nm).
  - b. Slide the hooks over the top of the guides. Install each locking pin through the hook lower hole.

- 3 Remove the plastic cover from the drive assembly relief fitting. **NOTE:** Failure to remove the cover may cause seal failure and leaking.

Check the oil level in the drive assembly. The oil level must be even with the end cover center plug. Fill if necessary with Cascade Gear Lube 656300 or equivalent SAE 90 wt. lube (AGMA "mild" 6EP gear oil).

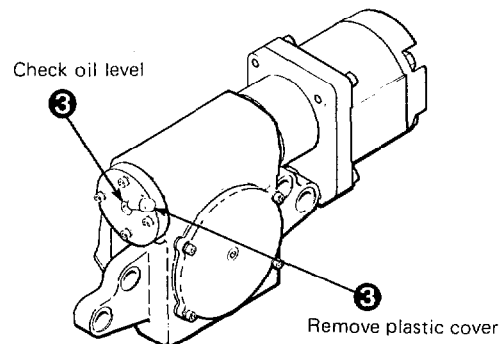
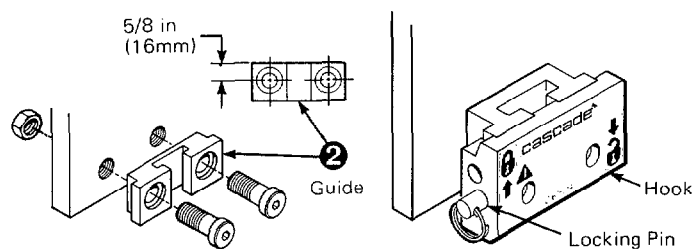
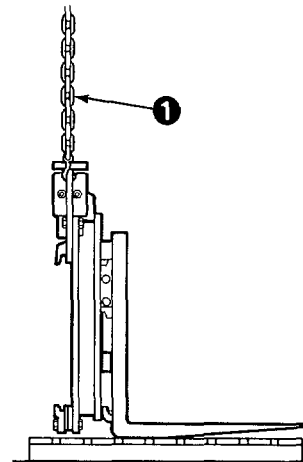
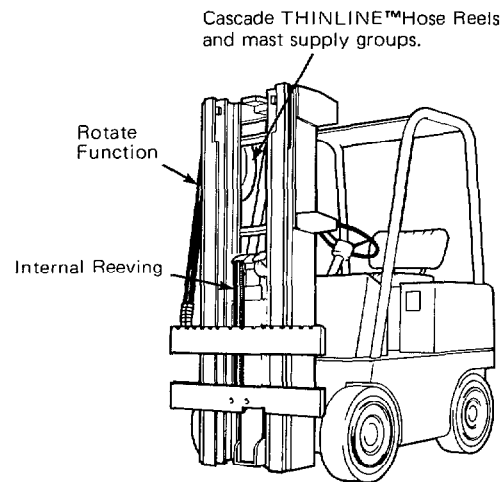

# Section 2 Installation Instructions

## 2.2-2 Attachment Installation (Continued)

- 4 Connect hydraulic hoses to the attachment fittings using Installation Kit 659245 **OR** use hoses and fittings as shown. Position the truck carriage behind the attachment to determine hose lengths required to connect hoses to the hose terminal or internal reeving fittings. Remove the hoses and cut to length as required.

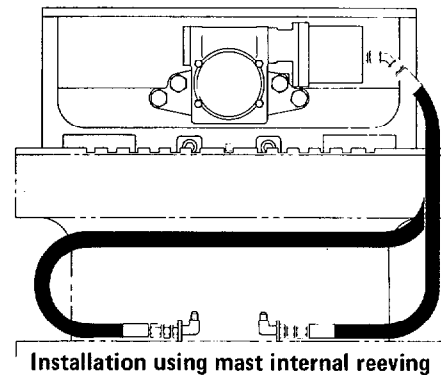
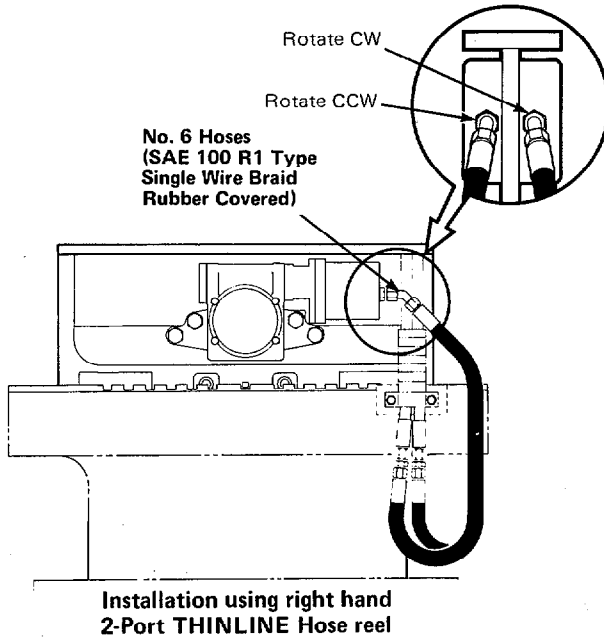

**CAUTION:** Flush the hoses as follows to prevent damage to the attachment hydraulic components. Failure to flush hoses could void warranty.

- 5 Connect the hoses to the truck hose terminal kit or internal reeving fittings. Connect the hoses together using union fittings. Start the truck and actuate the truck control valves in both directions for about 30 seconds to carry any debris left in the hoses to the truck hydraulic tank and filter.
- 6 Remove the union fitting.

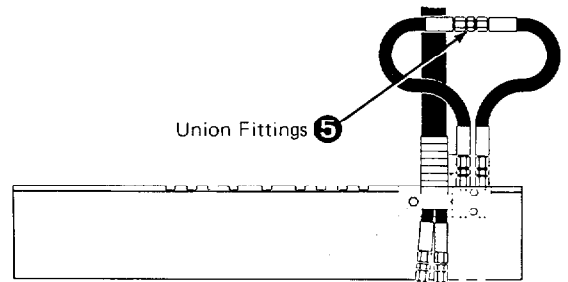

- 7 Center the attachment to the truck upper carriage bar. Engage the upper mounting hooks and locator tab with the center upper carriage bar notch. Lift the attachment 2 in. (5 cm) off the pallet.

**WARNING:** The mounting hooks must be properly engaged with the upper carriage bar.

**WARNING:** Stop Block Kit 669344 must be installed as described in step 10.

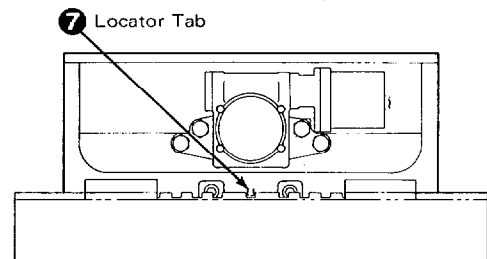

# Section 2 Installation Instructions

## 2.2-2 Attachment Installation (Continued)

- 8 Engage the lower hooks with the truck lower carriage bar.

**Bolt On Hooks** - Install the hooks and capscrews. Tighten the capscrews finger tight. Tap the end of the hooks with a hammer in the direction of the adjust arrow for maximum engagement with the carriage bar. Tighten the capscrews to a torque of 110-120 ft.-lbs. (150-165 Nm).

**Quick Change Hooks** - Remove the locking pins. Slide the hooks up to engage with the carriage bar. Install the locking pins through the upper holes.

**CAUTION:** If the clearance between the carriage bar and the hooks exceeds 3/16 in. (6 mm), the guides (refer to step 2) should be inverted and installed with the hole offset downward 5/8 in. (16 mm) from bottom of guide to hole center to minimize the gap.

### Bolt On Hooks

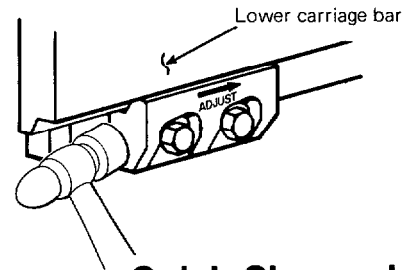

### Quick Change Hooks

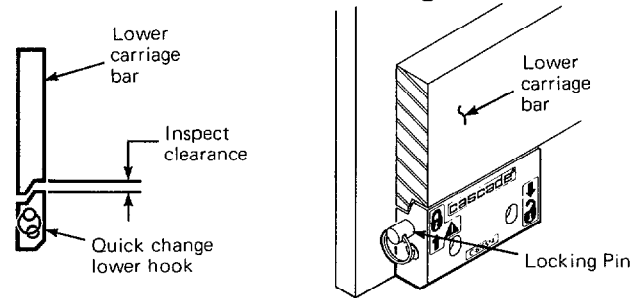

- 9 Connect the hydraulic hoses to the attachment fittings. See the chart below for correct auxiliary valve and attachment function operation.

Function, in sequence of location to the operator.	Attachment Movement	Motion of the operator's hand when actuating the truck auxiliary control handle while facing the load.
Rotate	Clockwise	Rearward or Up
	Counterclockwise	Forward or Down

2921-19'10

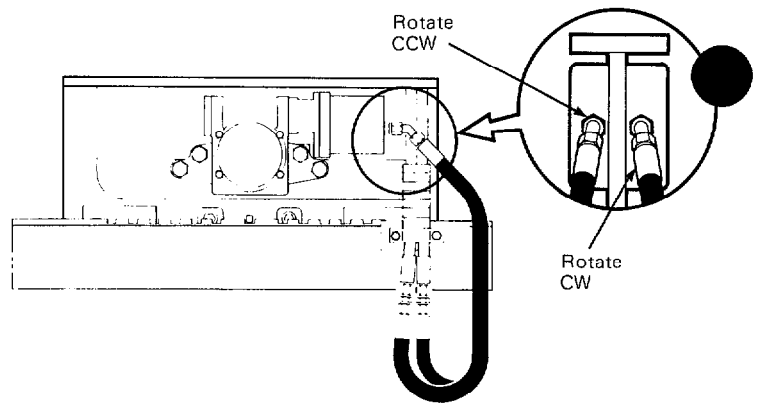

- 10 Install stop block kit 669344 to prevent the attachment from shifting or sliding on the truck carriage. Position each stop block on the truck upper carriage bar approximately 1/16 in. (1.5 mm) from the outward side of each upper mounting hook. If the carriage bar is not wide enough, place the stop blocks on the inward side of the hooks.

Preheat the upper carriage crossbar weld area and stop block to 400° F (200° C).

**CAUTION:** Protect all hydraulic hoses and components from excess heat and weld splatter.

Use AWS E-7018 low hydrogen rod and weld a 1/4 in. (6 mm) fillet as shown. Let the weld slow cool.

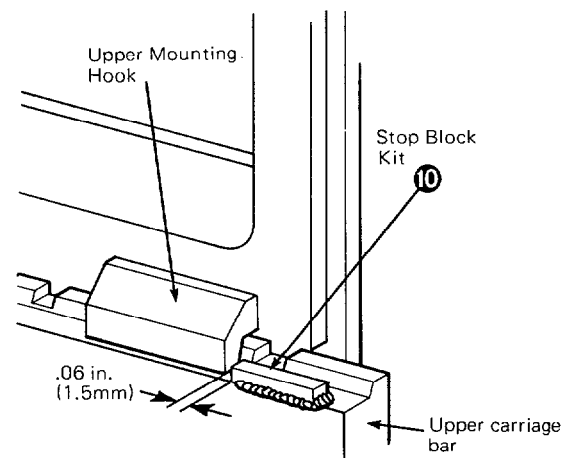

# Section 2 Installation Instructions

## 2.3 Fork Middle Hook Installation

- 1 Position the middle hook using the dimensions shown.
- 2 Mark the hook position on the fork.
- 3 Tack weld hook to the fork bar using FCAW\* 110 T5-K3 electrode.
- 4 Weld a .38 in. (9 mm) fillet on all four sides of the hook using the following specifications:
  - Oven preheat only the fork to 350° F (180° C) for 1.5 hour.
  - Weld using FCAW\* 110 T5-K3 electrode. Use 100% CO<sub>2</sub> shielding gas. Use voltage and amperage per the manufacturers specifications.
  - Cover the weldment with an insulation blanket and slow cool.

\* Flux Core Arc Weld

**WARNING:** Each fork must have three hooks. Cascade forks for rotators are equipped with a middle hook. If the rotator is supplied without forks, middle hooks are provided. They must be welded using the following procedures.

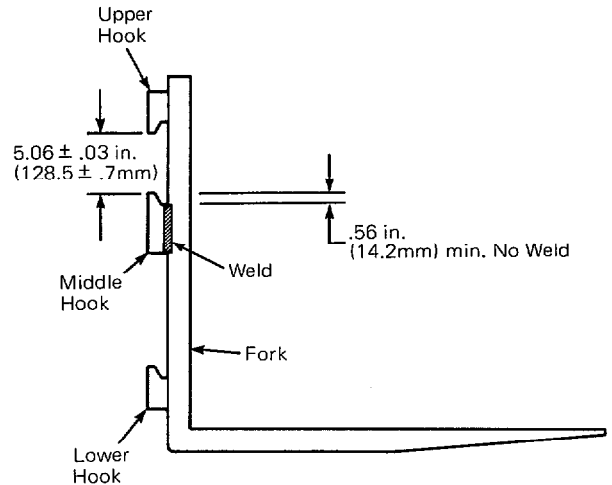

## 2.4 How To Install and Position Forks

**WARNING:** Each fork must have three hooks. Cascade forks for rotators are equipped with a middle hook. If the rotator is supplied without forks, middle hooks are provided. They must be welded using the following procedures.

- 1 Remove the fork keeper at one end of the carriage.
- 2 Release the spring lock on the top of each fork.
- 3 Slide the forks into position on the fork bars.
- 4 Lock each fork in place by pushing the spring lock lever down. Make sure the pin is engaged in the fork bar notch.
- 5 Install the fork keeper on the end of the carriage. Tighten the capscrews to a torque of 50-60 ft.-lbs. (67-82 N·m).
- 6 Removal is a reversal of installation.

**WARNING:** When removing the forks, handle with care to avoid dropping. The fork keeper must be in place at all times during rotator operation.

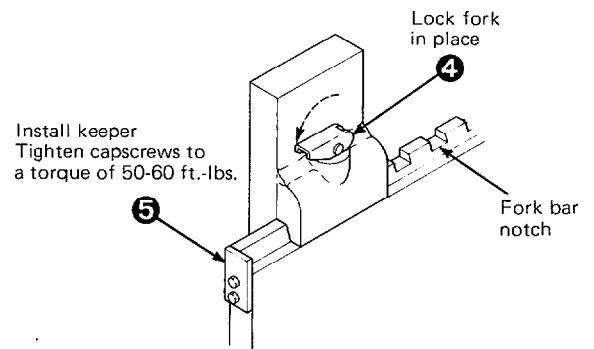
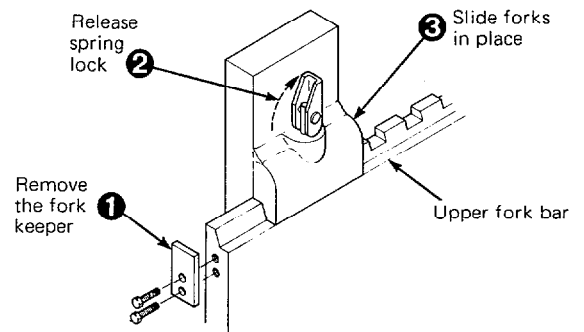

# Section 2 Installation Instructions

## 2.5 Prior to Operation

- 1 Check for external leaks at the hoses and fittings.



**WARNING:** Make sure there are no people in the vicinity of the attachment when picking up a load.

- 2 Before picking up a load, operate the rotator through 360° in both directions to force air from the system to the truck hydraulic tank.
- 3 Pick up a maximum load and rotate in both directions. If the attachment is sluggish or does not rotate smoothly, recheck the plumbing. If the attachment still operates incorrectly, contact one of the Cascade Service Departments listed on the back cover.
- 4 The auxiliary valve must actuate the rotator functions as shown in the chart in the Requirements Section 6.1-1. If the functions are backwards from the requirements, switch the hoses at the hose reel mounting block or auxiliary valve fittings.

# Section 3 Periodic Maintenance

## 3.1 500 Hour Maintenance

- ❑ Tighten the faceplate/bearing assembly and baseplate/bearing assembly capscrews. Refer to Section 5.4-1.
- ❑ Lubricate the rotator bearing assembly grease fitting with bearing grease. Lube and rotate the clamp several times. Refer to Section 5.4-1 step 7.
- ❑ Tighten the mounting hook capscrews. See the torque specifications shown in Section 2.2-2, step 2.
  
- ❑ Check the oil level in the drive assembly. The oil level must be up to the end cover center plug. To add oil, remove the breather cap (on the 90° fitting). Fill through the 90° fitting with Cascade Gear Lube 656300 or equivalent SAE 90 wt. lube (AGMA "mild" 6 EP gear oil) until lube begins to run from the end cap center hole.
- ❑ Check the Rotator maximum operating pressure. Refer to Section 4.1-1.

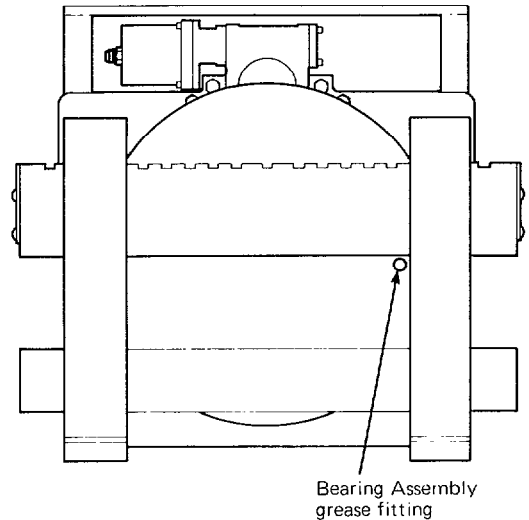

# 4 Troubleshooting

## 4.1 General Procedures



**WARNING:** Before servicing any hydraulic component, relieve pressure in the system. Turn the truck off and open the truck auxiliary valves several times in both directions.

After completing any service procedure, always test the function through several cycles. First test the attachment empty to bleed air trapped in the system to the truck tank. Then test the attachment with a load to be sure it operates correctly before returning it to the job.

Stay clear of the load while testing. Raise the load to the minimum height that will allow rotation of the load while testing.

Hydraulic Specifications	
<b>Pressure – Maximum</b>	2300 psi (160 bar)
<b>Recommended</b>	2000 psi (140 bar)
<b>Flow – Minimum★</b>	5 GPM (19L/min)
<b>Recommended</b>	7 GPM (26L/min)
<b>Maximum‡</b>	10 GPM (38L/min)
<b>Supply Hose and Fitting Size</b>	No. 6
<b>Minimum Orifice Size</b>	9/32 in. (7mm)

★ Flow less than minimum will result in a rotate speed less than 2 rpm.  
‡ Flow greater than maximum can result in excessive heating, reduced system performance and short hydraulic system life.

**Hydraulic Oil** – Cascade attachments are compatible with SAE 10W petroleum base oil per Mil. Spec. MIL-O-5606 or MIL-O-2104B.  
Use of synthetic or aqueous base hydraulic oil is not recommended. Contact Cascade if fire resistant hydraulic oil must be used.

27781-198/8

### 4.1-1 Truck System Requirements

- The lift truck must supply sufficient hydraulic pressure to handle the heaviest load. PRESSURE MUST NOT EXCEED 2300 PSI (160 BAR).
- Hydraulic flow should fall within the volume range shown in the chart.
- The truck hydraulic system must supply hydraulic oil to the attachment that meets the specifications shown in the chart.

### 4.1-2 Tools Required

In addition to a normal selection of hand tools, you will need:

- A flow meter capable of measuring hydraulic flow to 20 GPM (75 L/min.). The parts shown are included in Cascade Flow Meter Kit part no. 671477.
- Two pressure gauges capable of measuring pressure to 2500 PSI (175 BAR). The parts shown are included in Cascade Pressure Gauge Kit part no. 671212. Two kits are required.
- Assorted fittings and two No. 6 hoses as shown to adapt the gauges and flow meter to the components being tested.

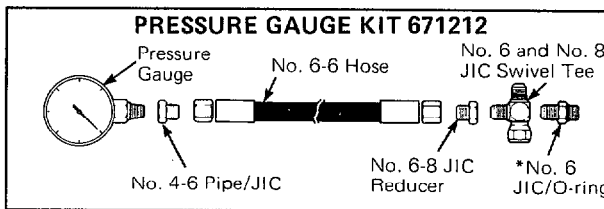
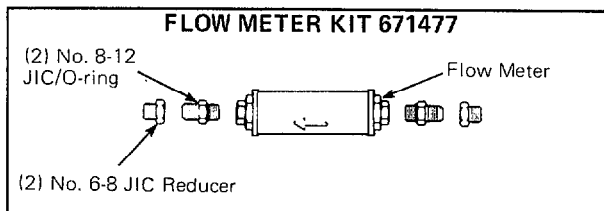

\*Not included in Pressure Gauge Kit part no. 671212

## 4.1-3 Get All The Facts

It is important that you gather all the facts regarding the problem before you begin service procedures. The best way is to talk with the operator. Ask for a complete description of the problem. The following guidelines will help you decide where to begin your troubleshooting procedures.

### ROTATE CIRCUIT

- Attachment will not rotate.
- Attachment will not rotate up to its rated capacity.
- Attachment rotates in one direction only.

If you encounter one of these problems, refer to Section 4.3.

# Section 4 Troubleshooting

## 4.2 Plumbing

### 4.2-1 Hosing Diagram

**ROTATE - CLOCKWISE (CW)**

**PRESSURE** 

**RETURN** 

(Reverse shading for CCW Rotate)

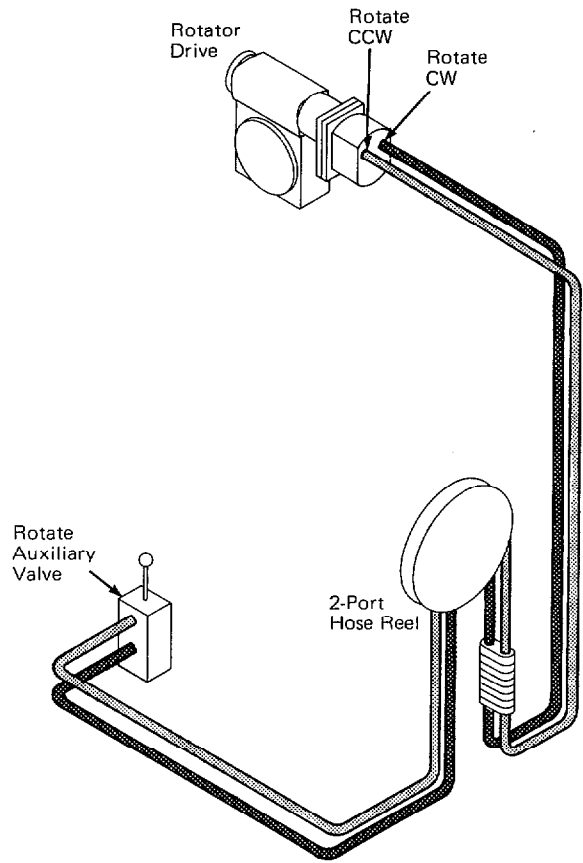

### 4.2-2 Circuit Schematic

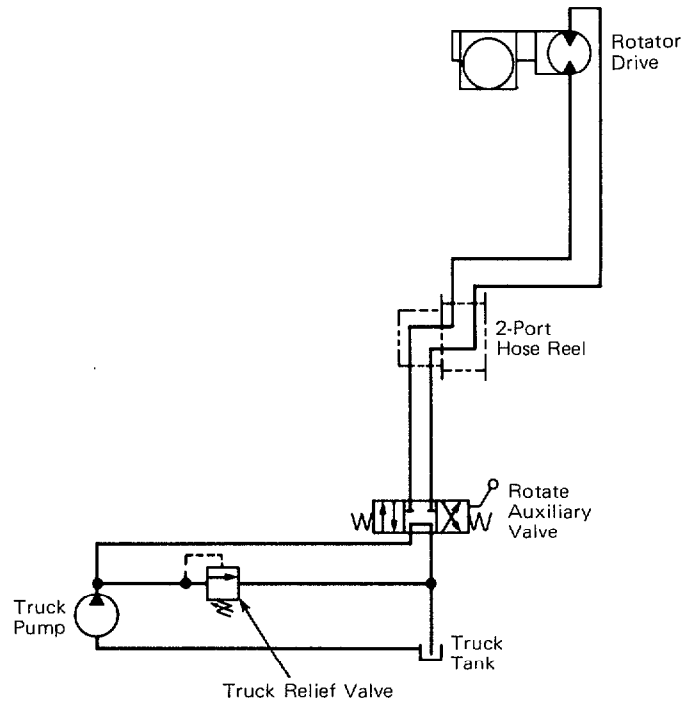

## 4.3

## Rotator Troubleshooting

There are four potential problem areas that could affect the rotate function.

- ❑ Operator may be handling loads beyond the capacity of the attachment. Loads rotated off-center may exceed attachment capacity.
- ❑ Insufficient hydraulic pressure and flow from the lift truck.
- ❑ Worn or defective motor.
- ❑ Worn or defective drive assembly or frame bearing assembly.

### 4.3-1 Supply Circuit Test



**WARNING:** Before removing the supply hoses, relieve pressure in the hydraulic system. Turn the truck off, then open the truck auxiliary control valves several times in both directions.

- ① Check the pressure delivered by the truck to the carriage hose terminal. Refer to the truck service manual. The pressure must be within 100 psi (7 bar) of specified truck pressure. **TRUCK PRESSURE MUST NOT EXCEED 2300 PSI (160 BAR),** measured at the hose terminal.
- ② Check the flow volume at the hose terminal. See Section 6.1-1 for the recommended flow volumes.
- ③ Check for external leaks.

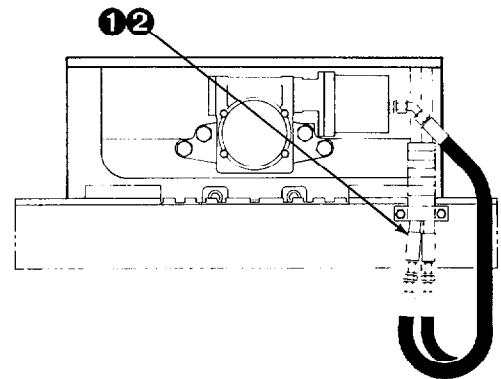

### 4.3-2 Rotation without a Load



**WARNING:** Before installing the gauges, relieve pressure in the hydraulic system. Turn the truck off, then open the truck auxiliary control valves several times in both directions.

- ① Install pressure gauges to the motor fittings.
- ② Start the truck and rotate the attachment without a load. While rotating, note pressure readings of both gauges.
  - If the lower gauge reading exceeds 500 psi (35 bar), there is excessive back pressure in the supply circuit. Check for restrictions such as numerous fittings and hose sizes less than No. 6, with 9/32 in. (7 mm) minimum orifices.

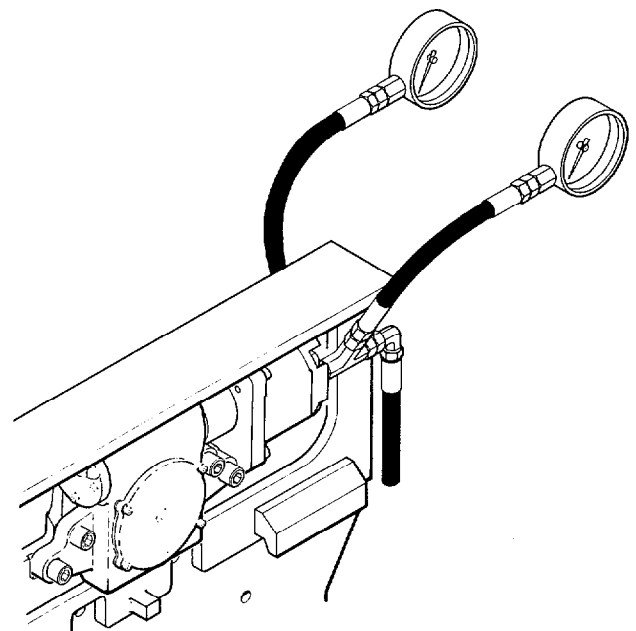

## 4.3-3 Rotation with a Load

- ❶ Rotate a load requiring approximately 24,000 in.-lbs. @ 2000 psi (2712 Nm @ 140 bar) torque. Refer to Section 6.1-4 to determine load required. Note gauge readings during rotation.
  - If the higher gauge reading is substantially less than truck pressure measured at the carriage hose terminal, the motor gear set may need repair. Refer to Section 5.3.
  - If the higher gauge reading is close to truck pressure measured at the carriage hose terminal and no rotation occurs, the motor output shaft or drive box may need repair. Continue troubleshooting.
- ❷ Remove the motor from the drive box assembly as described in Section 5.3-1.
- ❸ Reinstall the hoses to the motor fittings. Actuate the rotate circuit.
  - If the motor shows rotational output, the drive box may require service. Refer to Section 5.2-2.
  - If the motor shows little or no rotational output, service the motor as described in Section 5.3-2.

## 5.1 Attachment Removal

- 1 Rotate the attachment to position the forks parallel to the ground.
- 2 Remove the fork keeper at each end of the carriage. For reassembly, tighten the capscrews to a torque of 50-60 ft.-lbs. (67-82 N·m).
- 3 Release the spring lock on the top of each fork. Remove the forks from the rotator.
- 4 Remove the lower hooks.

**Bolt On Hooks** - Remove the lower mounting hooks. For reassembly, tighten the capscrews to a torque of 105-115 ft.-lbs. (142-155 Nm)

**Quick Change Hooks** - Pull out the locking pins, slide the hooks down and reinstall the pins in the lower holes. For reassembly, slide the hooks up and install the pins in the top holes.



**WARNING:** Before removing any hoses, relieve pressure in the hydraulic system. Turn the truck off, then open the auxiliary control valve(s) several times in both directions.

- 5 Disconnect and plug the hydraulic hoses to the attachment. Tag the hoses for reassembly.
- 6 Install a hoist to the attachment. Tilt the mast forward. Remove the attachment from the lift truck and place on a pallet.
- 7 For installation, reverse the above procedures and refer to the Installation Instructions, Section 2.

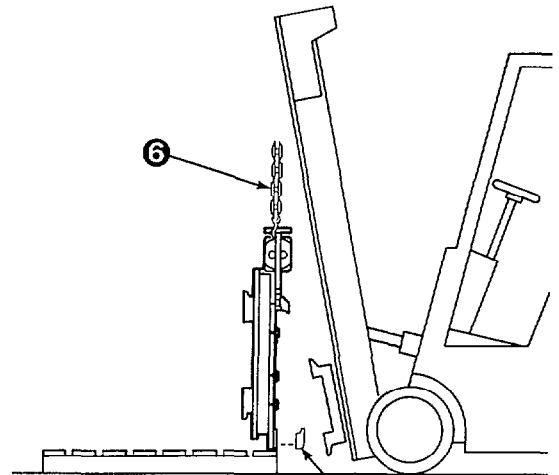
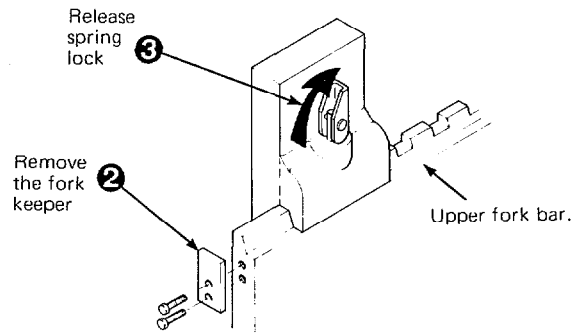

**Bolt On Hooks 4**

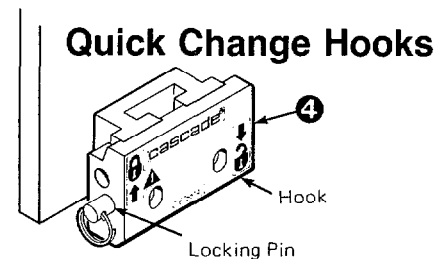

**Quick Change Hooks**

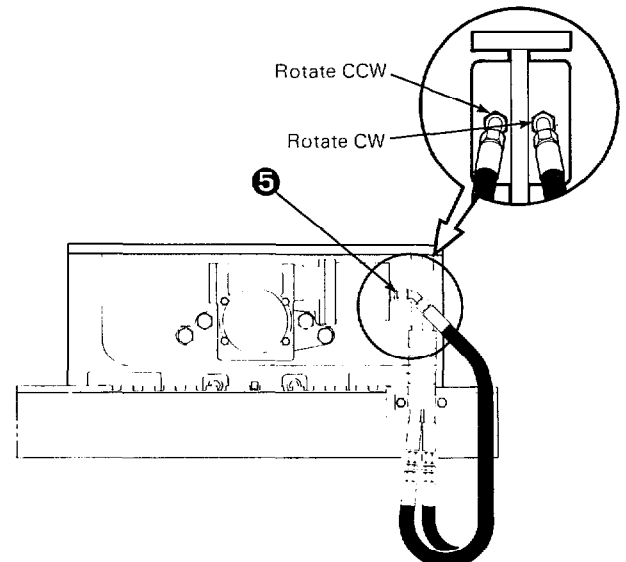

# Section 5 Service

## 5.2 Drive Group

### 5.2-1 Drive Group Removal and Installation

- ① Remove the attachment from the truck as described in Section 5.1.
- ② Remove the four capscrews fastening the drive group to the baseplate. For reassembly, tighten the capscrews to a torque of 110-120 ft.-lbs. (150-165 Nm).
- ③ For reassembly, reverse the above procedures except as follows:
  - After the drive group has been installed, check the oil level in the drive assembly. The oil level must be up to the end cover center plug. To add oil, remove the breather cap (on the 90° fitting) . Fill through the 90° fitting with Cascade Gear Lube 656300 or equivalent SAE 90 wt. lube (AGMA "mild" 6 EP Gear Oil) until lube begins to run from the end cap center hole.

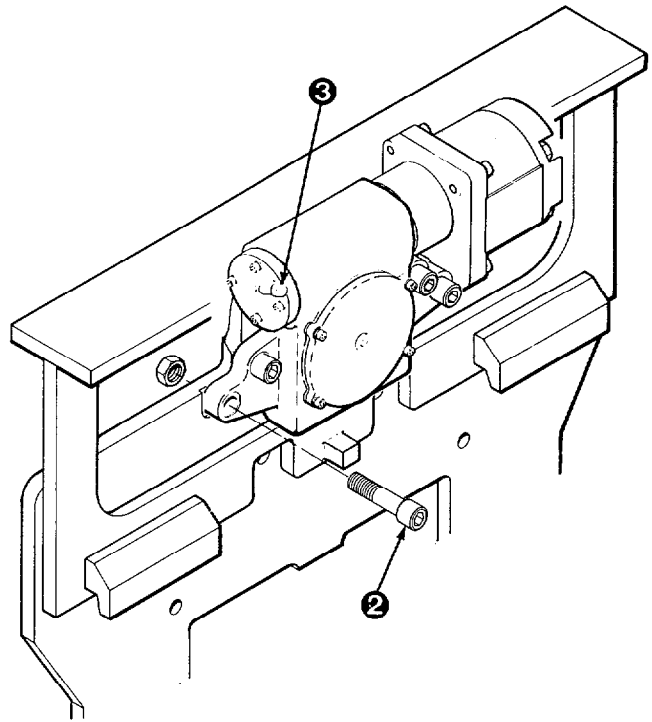

## 5.2-2 Drive Group Disassembly and Service

- ❶ Remove the drive group from the attachment as described in Section 5.2-1.
- ❷ Lay the drive group, pinion down, on wooden blocks approx. 4 X 4 in. (100 X 100 mm) placed on both sides of the pinion.
- ❸ Remove the cover plate from the housing.
- ❹ Drain oil from the housing.
- ❺ Remove the end cover from the housing.
- ❻ Remove the drive motor as described in Section 5.3-1.
- ❼ Remove the motor adapter from the housing.

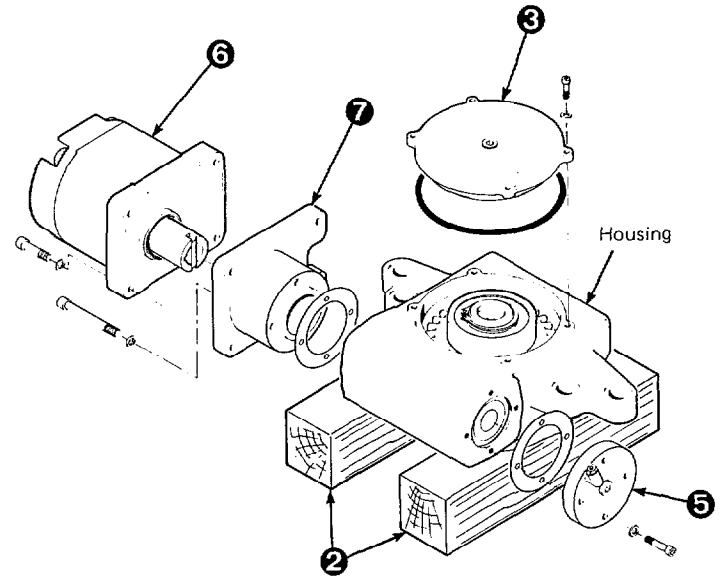

- ❽ Tap and rotate the worm and worm bearing out through the end cover side of the housing. Remove the worm bearing from the motor side of the housing.
- ❾ Press the pinion, pinion bearings and worm gear out of the housing as an assembly.
- ❿ Remove the snap ring from the pinion. Press the pinion and housing/pinion bearing from the worm gear and cover plate/pinion bearing. Remove the pinion key.
- ⓫ Press the pinion out of the housing/pinion bearing.
- ⓬ Clean and inspect all components. Remove all dried sealant residue. Replace all worn items. Remove burrs and sharp edges with emery cloth.

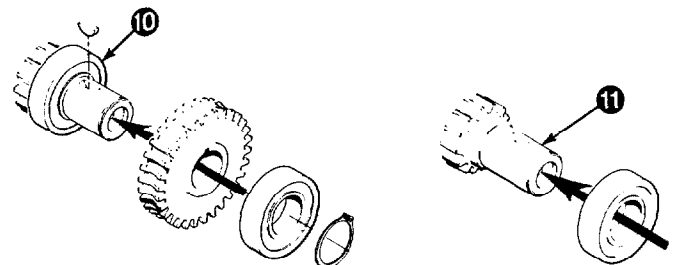
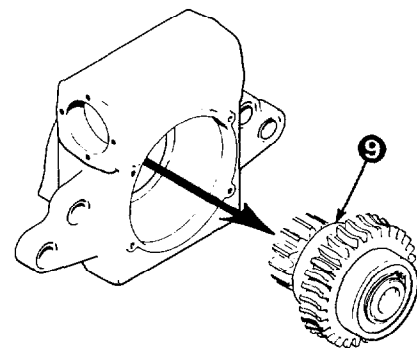
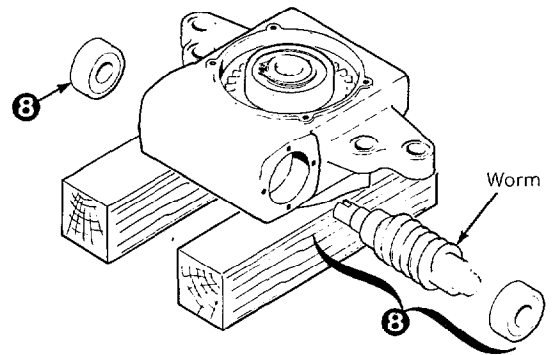

# Section 5 Service

## 5.2-3 Drive Group Reassembly

- 1 Apply sealant 668184 to the pinion shaft seating area and shoulder for the housing/pinion bearing. Install the housing/pinion bearing. Remove excess sealant.
- 2 Install the key, worm gear, cover plate/pinion bearing and snap ring on the pinion.

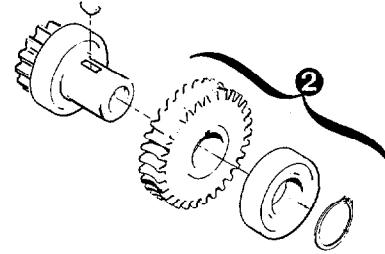
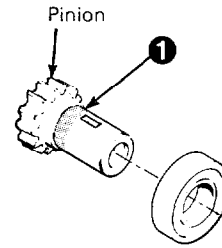

- 3 Apply sealant 668184 to the housing seating area and shoulder for the housing/pinion bearing. Install the pinion assembly in the housing. Remove excess sealant.
- 4 Install the worm and worm bearings in the housing. The bearings must be installed using the race orientation shown below. **The manufacturers stampings must be visible on the outer race.**

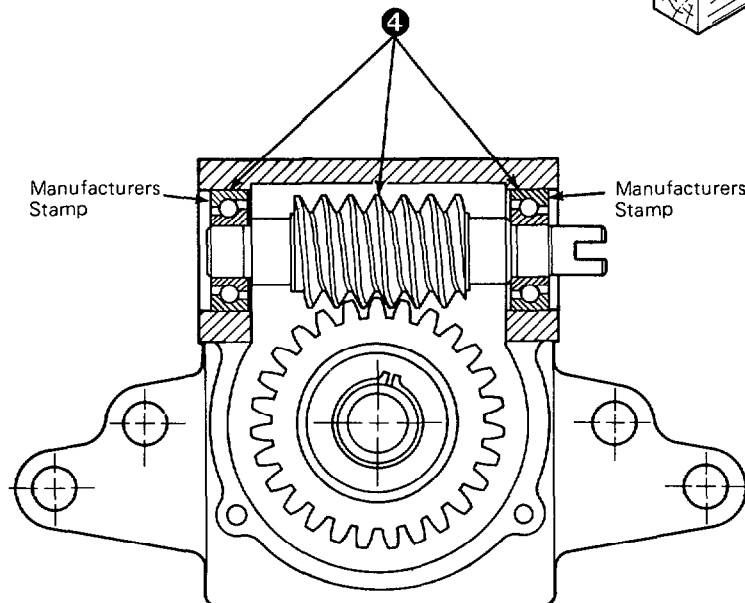
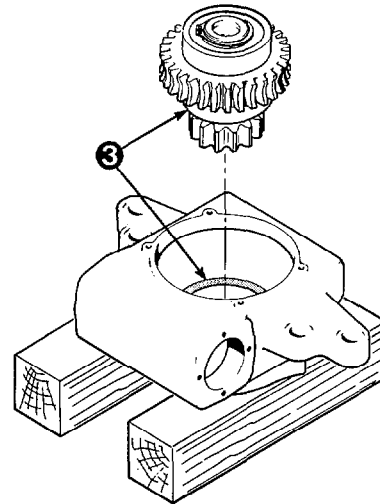

## 5.2-3 Drive Group Reassembly (Continued)

- ⑤ Apply sealant 668184 to both sides of the motor adapter shim. Install the motor drive adapter. Tighten the capscrews to a torque of 60-80 in.-lbs. (7-9 Nm).
- ⑥ Apply sealant 668184 to both sides of the end cover shim. Install the end cover. Tighten the capscrews to a torque of 60-80 in.-lbs. (7-9 Nm).

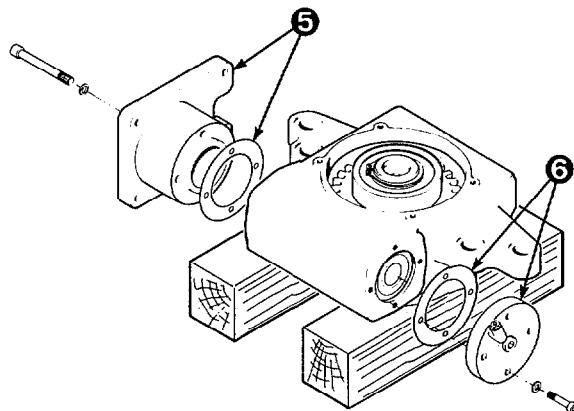

- ⑦ Install the drive motor. Make sure the drive adapter is fully engaged with the worm shaft. Tighten the capscrews to a torque of 60-80 in.-lbs. (7-9 Nm).
- ⑧ Install the cover plate. Tighten the capscrews to a torque of 60-80 in.-lbs. (7-9 Nm).
- ⑨ Remove the center plug and breather cap (on the 90° fitting) from the end cap.
- ⑩ Fill the drive group through the 90° fitting with Cascade Gear Lube 656300 or equivalent SAE 90 wt. lube (AGMA "mild" 6EP Gear Oil) until lube begins to run from the end cap center hole.
- ⑪ Install the center plug and breather cap (on the 90° fitting) to the end cap.
- ⑫ Install the drive group to the attachment baseplate as described in Section 5.2-1.

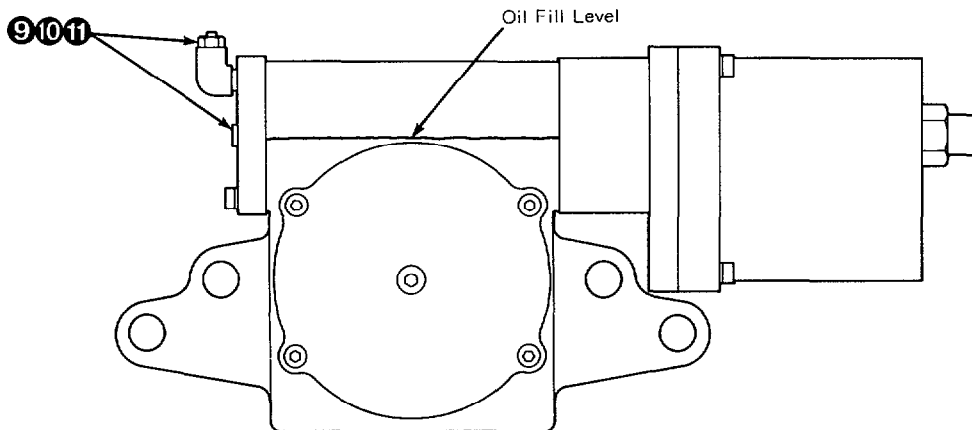
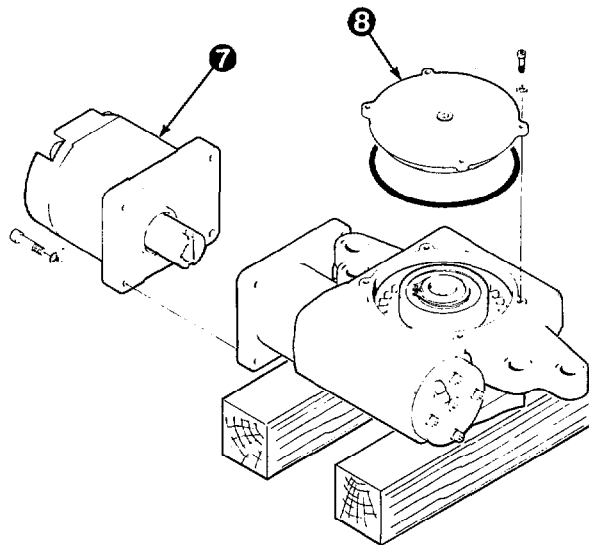

# Section 5 Service

## 5.3 Drive Motor

### 5.3-1 Drive Motor Removal and Installation



**WARNING:** Before removing the supply hoses, relieve pressure in the hydraulic system. Turn the truck off, then open the truck auxiliary control valves several times in both directions.

- ❶ Remove the attachment from the lift truck as described in Section 5.1.
- ❷ Remove the drive group from the attachment as described in Section 5.2-1.
- ❸ Remove the center plug from the end cap and drain oil from the drive group.
- ❹ Remove the four capscrews fastening the drive motor to the motor adapter.
- ❺ For reassembly, reverse the above procedures except as follows:
  - Apply sealant 668184 to the motor face. Install the motor and tighten the capscrews to a torque of 60-80 in.-lbs. (7-9 Nm).
  - After the drive group has been installed, check the oil level in the drive assembly. The oil level must be up to the end cover center plug. To add oil, remove the breather cap (on the 90° fitting). Fill through the 90° fitting with Cascade Gear Lube 656300 or equivalent SAE 90 wt. lube (AGMA "mild" 6 EP Gear Oil) until lube begins to run from the end cap center hole.

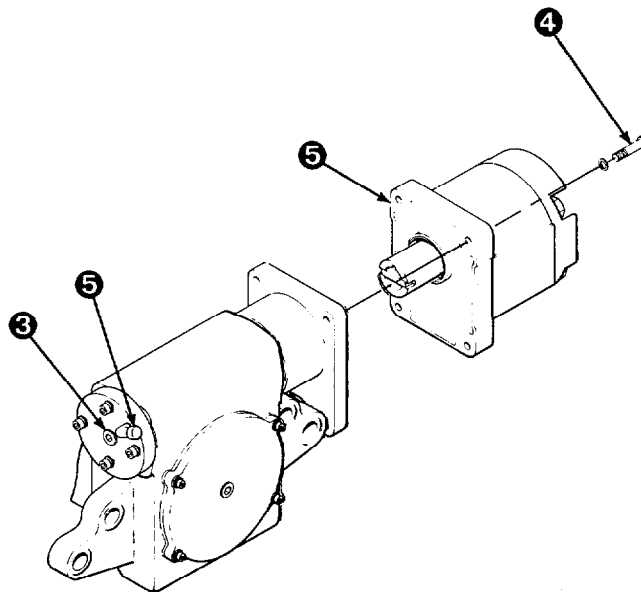

## 5.3-2 Drive Motor Disassembly

- 1 Remove the drive motor from the drive group as described in Section 5.3-1.

**IMPORTANT:** Service the drive motor in a clean work area.

- 2 Drain oil from the drive motor by rotating the shaft. Plug the ports. Wash the outside of the drive motor with solvent and blow dry.
- 3 Remove the key and circlip from the shaft.
- 4 Mark the cover, body and flange for reassembly.

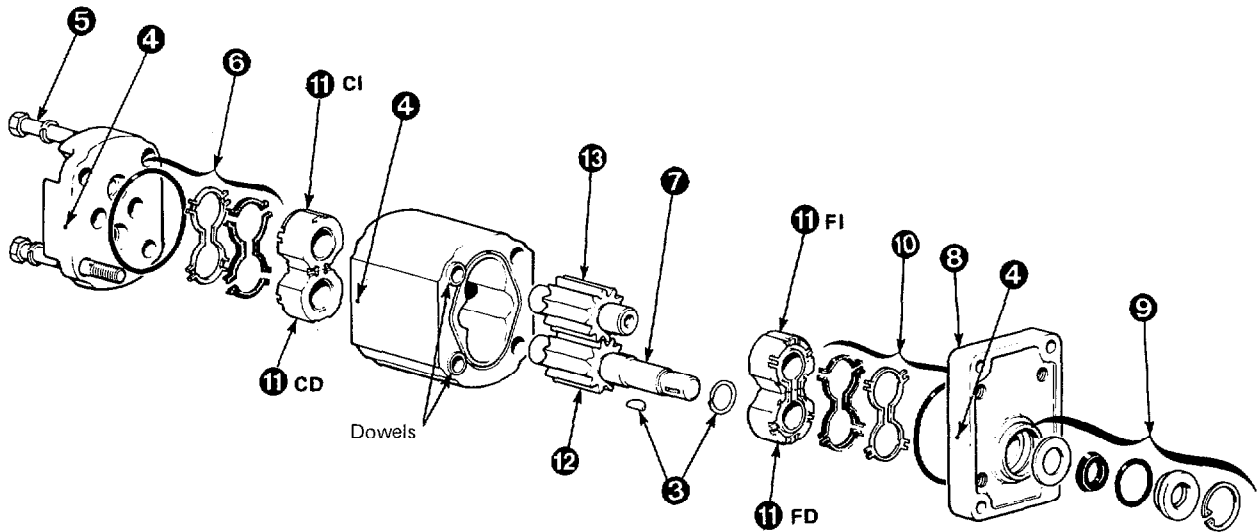

- 5 Remove the cover bolts.
- 6 Remove the cover and lift off the back-up seal, bushing seals and body O-ring.
- 7 Remove any burrs from the shaft.
- 8 Tap the flange to disengage it from the locating in the body. Slide the flange squarely off the shaft.
- 9 Remove the internal snap ring from the mounting flange. Push the shaft oil seal squarely out of the mounting flange. Do not damage any sealing surfaces.
- 10 Remove the back-up seal, bushing seals and body O-ring.
- 11 Before removing the internal components, each of the bushings must be marked to identify its position in the body. On the surface of the bushing (which will not affect unit sealing), lightly mark:

FD = Flange Drive Shaft Bushing  
 FI = Flange Idler Gear Bushing  
 CI = Cover Idler Gear Bushing  
 CD = Cover Drive Shaft Bushing

- 12 Lay the unit on its side. Pull the drive shaft squarely out of the body with the bushings.
- 13 Remove the idler gear and two remaining bushings.

# Section 5 Service

## 5.3-3 Drive Motor Inspection

- ❶ Clean all parts with solvent and blow dry. **Do not use paper or cloth towels.**
- ❷ Inspect the body bore where the two gears wipe into the body. The body can be reused if the "cut-in" is bright and polished and the depth does not exceed .003 in. The body should be replaced if the tips of the gears have dug into the surface material.
- ❸ Inspect the body O-ring seal areas for defects that could cause leakage.
- ❹ Inspect the flange and cover for wear or scoring in the body O-ring, bushing seal and back-up seal areas that could cause leakage.
- ❺ Check the shaft seal seat for scoring or damage that could cause leakage.
- ❻ The bushing side faces that are adjacent to the gears should be perfectly flat with no signs of scoring or steps. These surfaces should be brightly polished from the side loading of the gears. This is a critical sealing surface and must be completely flat to the gear side face.  
  
The bushing bores should not be scored or show other signs of damage.
- ❼ Check for scoring or a wear step on the gear side faces. If scoring or a step can be felt, replace the gear.
- ❽ Check the gear teeth for signs of pitting or scoring.
- ❾ The gear bearing journal surfaces should be completely free of scoring.
- ❿ Check the area where the shaft lip seal runs on the drive shaft. If a noticeable groove can be felt, the shaft should be replaced.

**IMPORTANT:** If either of the gears are damaged, they must be replaced as a matched pair.

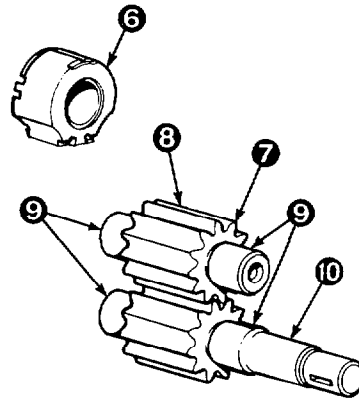
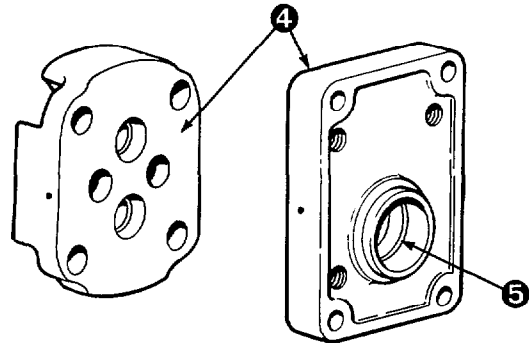
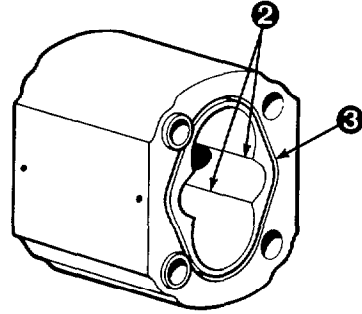

# Section 5 Service

## 5.3-4 Drive Motor Reassembly

When a drive motor has been disassembled, all seals should be replaced. Make sure all components are clean prior to assembly.

- 1 Place the cover against the body and position the assembly so that the dowels are uppermost.
- 2 Install the drive shaft and idler gear into the body.
- 3 Install the flange drive shaft bushing **FD** and flange idler gear bushing **FI** into their original bores.
- 4 Install new seals and back-up seal to the bushings. The flat side of the back-up seal must be toward the flange. Install the body O-ring.
- 5 Install the flange (without shaft seals). Align squarely to the body dowels.
- 6 Turn the assembly over and remove the cover.
- 7 Install the cover drive shaft bushing **CD** and cover idler gear bushing **CI** into their original bores.
- 8 Install new seals and back-up seal to the bushings. The flat side of the back-up seal must be toward the cover. Install the body O-ring.
- 9 Install the cover and capscrews. Tighten the capscrews to a torque of 32-38 ft.-lbs. (43-51 Nm).
- 10 Pour a small amount of oil into the port and check for easy shaft rotation.
- 11 Lubricate the shaft seals and flange seal seat with hydraulic oil. Install the seals and hardware to the flange.

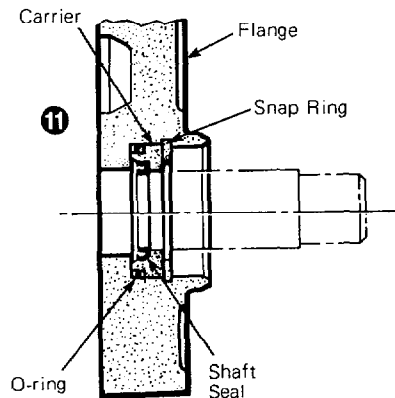
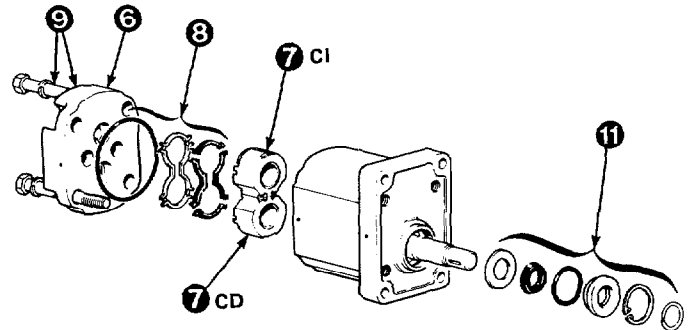
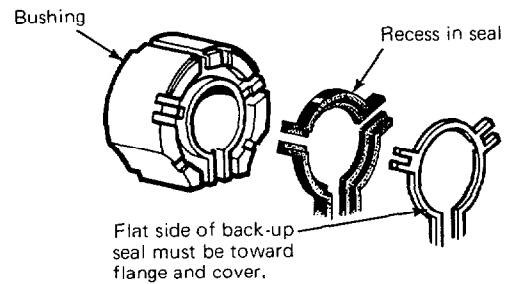
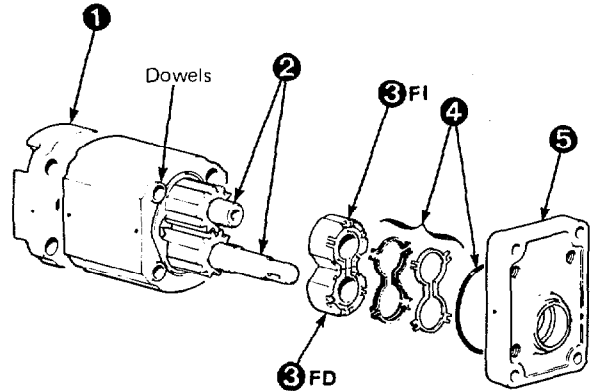

# Section 5 Service

## 5.4 Base Unit

### 5.4-1 Bearing Assembly Removal and Installation

- ❶ Remove the attachment from the lift truck as described in Section 5.1.
- ❷ Remove the drive group as described in Section 5.2-1.
- ❸ Remove the capscrews fastening the baseplate to the bearing assembly. For reassembly, tighten the capscrews to a torque of 110-120 ft.-lbs. (150-165 Nm).



**WARNING:** Make sure your hoist has a rated capacity of 1000 lbs. (450 kg).

- ❹ Attach an overhead hoist to the baseplate. Lift away the baseplate.
- ❺ Attach two eyebolts to the bearing assembly. Attach an overhead hoist.
- ❻ Remove the capscrews fastening the bearing assembly to the faceplate. For reassembly, tighten the capscrews to a torque of 110-120 ft.-lbs. (150-165 Nm). Lift away the bearing assembly.
- ❼ For reassembly, reverse the above procedures except as follows:
  - Align the bearing assembly inner race grease fitting with the access hole in the faceplate.
  - Tighten the capscrews to half torque value - 55 ft.-lbs. (75 Nm) using the pattern shown. Tighten to full torque value - 110-120 ft.-lbs. (150-165 Nm).
  - Apply NLGI No. 0 grease to the teeth of the bearing assembly gear teeth.
  - After remounting the attachment on the lift truck, apply chassis grease to the bearing assembly grease fitting. The fitting access hole is in the faceplate to one side between the fork bars. If the fitting is not visible, rotate 180°. Lube then rotate to distribute the grease. Apply grease and rotate several times.

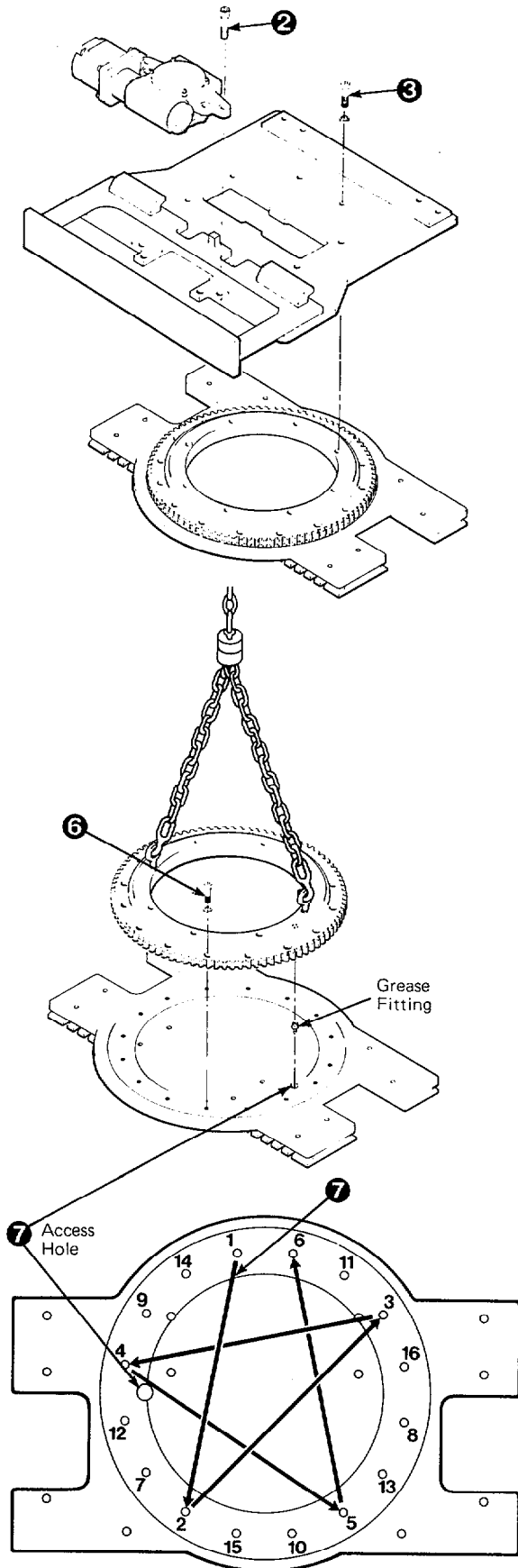

# 6 Specifications

## 6.1-1 Hydraulics

Hydraulic Specifications	
Pressure – Maximum	2300 psi (160 bar)
	Recommended 2000 psi (140 bar)
Flow – Minimum★	5 GPM (19L/min)
	Recommended 7 GPM (26L/min)
	Maximum‡ 10 GPM (38L/min)
Supply Hose and Fitting Size Minimum Orifice Size	No. 6 9/32 in. (7mm)

27781CH-269'8

- ★ Flow less than minimum will result in a rotate speed less than 2 rpm.
- ‡ Flow greater than maximum can result in excessive heating, reduced system performance and short hydraulic system life.

**Hydraulic Oil** - Cascade attachments are compatible with SAE 10W petroleum base oil per Mil. Spec. MIL-0-5606 or MIL-0-2104B.

Use of synthetic or aqueous base hydraulic oil is not recommended. Contact Cascade if fire resistant hydraulic oil must be used.

In order to conform to industry standard practice, the hoses should be connected to the truck as indicated by the chart.

Function, in sequence of location to the operator.	Attachment Movement	Motion of the operator's hand when actuating the truck auxiliary control handle while facing the load.
Rotate	Clockwise	Rearward or Up
	Counterclockwise	Forward or Down

2921-19 10

## 6.1-2 Truck Carriage

Truck carriage must conform to ISO dimensional standard 2328, equivalent to Industrial Truck Association (ITA) dimensions shown.

Make sure the truck carriage is clean and the notches are undamaged.

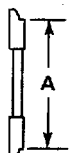

Mounting	Dimension A-ITA (ISO)	
	Minimum	Maximum
Class II	14.94 in. (380.0mm)	15.00 in. (381.0 mm)

27781CH-269'8

# Section 6 Specifications

## 6.1-3 Torque Values

Note that all specifications are shown in US and (Metric) units where applicable.

Ref. No.	Fastener Thread Size	Torque Values	
		Ft.-lbs.	(N·m)
1	M16	110–120	150–165
2	M6	6–8	7–9
3	M12	43–48	60–66
4	M16	100–110	135–150

2921-20/10

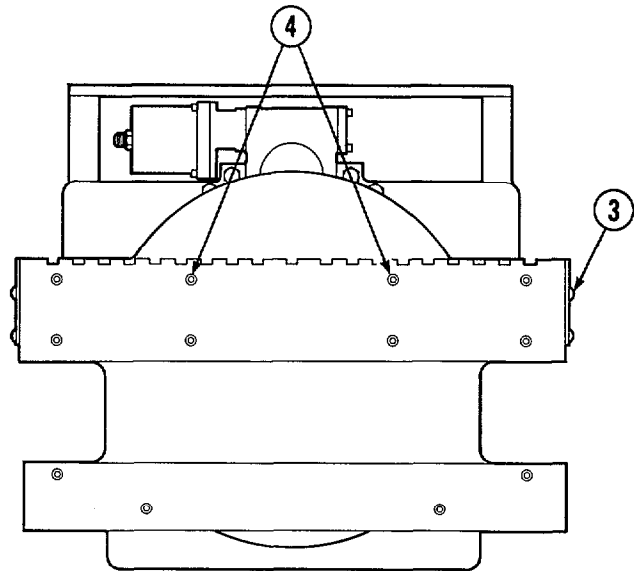
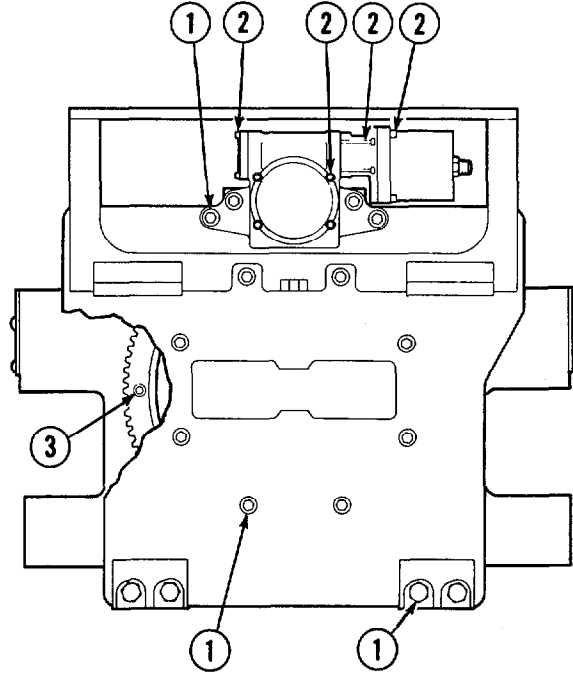

# 6 Specifications

## 6.1-4 Determining Load Torque Requirements

**IMPORTANT:** Positioning the load as close to center as possible will reduce the torque requirements and increase truck stability.

To make sure your Rotator will handle a specific load, calculate the torque requirement as follows.

- 1 Weigh the load to be handled. **Example:** 1500 lbs.
  - 2 Determine the center of the rotator faceplate. Draw a line between a set of faceplate holes that are 180° apart. Repeat for a second set of holes. Where they cross is the center point of the rotator.
  - 3 Determine the vertical off-center distance of the load. Measure from the load vertical centerline to the rotator vertical centerline.
  - 4 Determine the horizontal off-center distance of the load. Measure from the load horizontal centerline to the rotator horizontal centerline.
  - 5 Off-center distance calculation.
    - Square the vertical measurement. **Example:** (3 in.)<sup>2</sup> = 9 in.
    - Square the horizontal measurement. **Example:** (4 in.)<sup>2</sup> = 16 in.
    - Add these two figures together. **Example:** 9 in. + 16 in. = 25 in.
    - Determine the square root and you have the total off-center distance. **Example:** √25 in. = 5 in. off-center distance.
    - Multiply the total off-center distance by the load weight and you have the torque required to handle the load. Compare this figure to the rotator specifications in the chart.
- Example:** 5 in. X 1500 lbs. = 7500 in.-lbs.

Model	Maximum Torque Capacity
30E*	31,700 in.-lbs. (α 2000 psi) (3,580 N·m (α 140 bar))

\*Rated at 10 GPM (37 L/min.) flow. 2921a-21 10

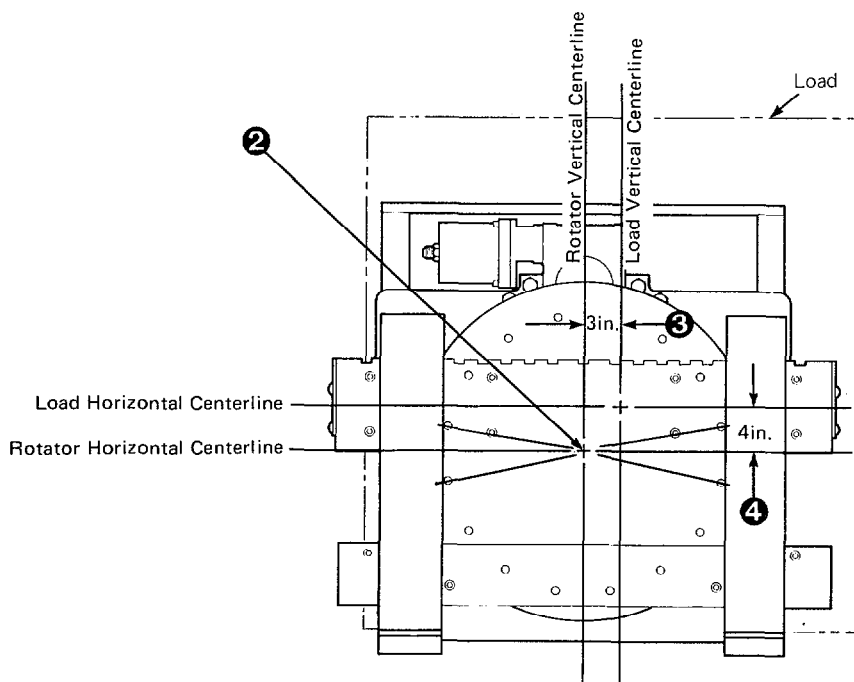

**Do you have questions you need answered right now? Call your nearest Cascade Service Department.**

### **AMERICAS**

**Cascade Corporation  
U.S. Headquarters**  
2201 NE 201st  
Fairview, OR 97024-9718  
Tel: 800-CASCADE (227-2233)  
Fax: 888-329-8207

**Cascade Canada Inc.**  
5570 Timberlea Blvd.  
Mississauga, Ontario  
Canada L4W-4M6  
Tel: 905-629-7777  
Fax: 905-629-7785

**Cascade do Brasil**  
Rua João Guerra, 134  
Macuco, Santos - SP  
Brasil 11015-130  
Tel: 55-13-2105-8800  
Fax: 55-13-2105-8899

### **EUROPE-AFRICA**

**Cascade Italia S.R.L.  
European Headquarters**  
Via Dell'Artigianato 1  
37050 Vago di Lavagno (VR)  
Italy  
Tel: 39-045-8989111  
Fax: 39-045-8989160

**Cascade (Africa) Pty. Ltd.**  
PO Box 625, Isando 1600  
60A Steel Road  
Sparton, Kempton Park  
South Africa  
Tel: 27-11-975-9240  
Fax: 27-11-394-1147

### **ASIA-PACIFIC**

**Cascade Japan Ltd.**  
2-23, 2-Chome,  
Kukuchi Nishimachi  
Amagasaki, Hyogo  
Japan, 661-0978  
Tel: 81-6-6420-9771  
Fax: 81-6-6420-9777

**Cascade Korea**  
121B 9L Namdong Ind.  
Complex, 691-8 Gojan-Dong  
Namdong-Ku  
Inchon, Korea  
Tel: +82-32-821-2051  
Fax: +82-32-821-2055

**Cascade-Xiamen**  
No. 668 Yangguang Rd.  
Xinyang Industrial Zone  
Haicang, Xiamen City  
Fujian Province  
P.R. China 361026  
Tel: 86-592-651-2500  
Fax: 86-592-651-2571

**Cascade India Material  
Handling Private Limited**  
No 34, Global Trade Centre  
1/1 Rambaugh Colony  
Lal Bahadur Shastri Road,  
Navi Peth, Pune 411 030  
(Maharashtra) India  
Phone: +91 020 2432 5490  
Fax: +91 020 2433 0881

**Cascade Australia Pty. Ltd.**  
1445 Ipswich Road  
Rocklea, QLD 4107  
Australia  
Tel: 1-800-227-223  
Fax: +61 7 3373-7333

**Cascade New Zealand**  
15 Ra Ora Drive  
East Tamaki, Auckland  
New Zealand  
Tel: +64-9-273-9136  
Fax: +64-9-273-9137

**Sunstream Industries  
Pte. Ltd.**  
18 Tuas South Street 5  
Singapore 637796  
Tel: +65-6795-7555  
Fax: +65-6863-1368