



Installation Instructions

Digital Tilt Indicator Kits 6802582 (12V) and 6812299 (24-48V)

This sheet describes the installation and operation for Cascade's Digital Tilt Indicator. The tilt indicator allows the driver to easily determine if the attachment or forks are properly aligned to the load.

INSTALLATION

IMPORTANT: Read all instructions prior to installation to prevent injury or product damage.

- Forks and Platens** – Position the mast at vertical using a level.
Attachments with Arms – Position front edge of pads at vertical.
- Locate a place on the mast to mount the tilt indicator that is convenient for the operator to see the tilt indicator's LED's. Mark the area. This location may be on the LH side if the driver normally sights down the LH side for positioning.
 - The unit is supplied with the bracket setup for LH mounting. Switch to RH mounting by removing the top screws and turning the bracket 180° (keep the bottom label with red dot facing down).
- Clean the marked area of grease, dirt and contaminants.
- The unit is not polarity sensitive. Connect the wires to a switched power source. See schematics below. Use 18-22 AWG wire as needed. Allow wire length for the mast to fully tilt forward and backward. Route and anchor the wires to avoid pinching.

Digital Tilt Indicator

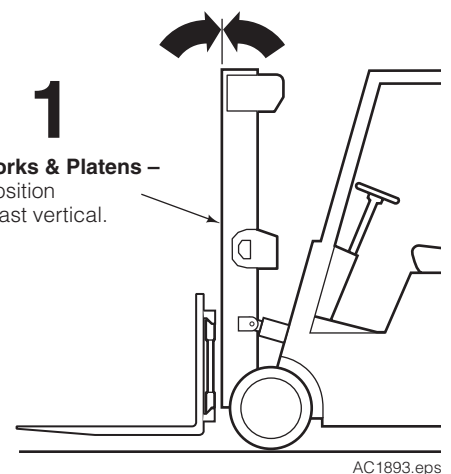
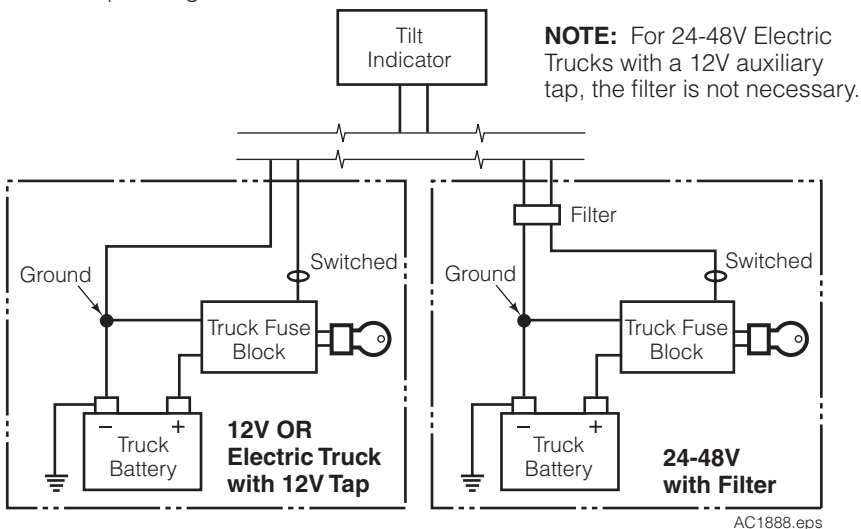
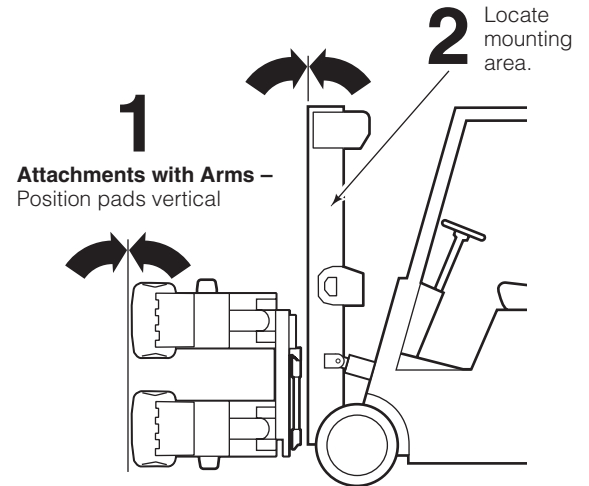
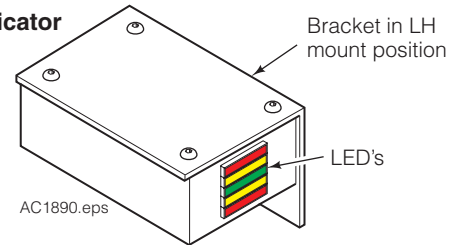

cascade®
corporation

For Technical Support . . .

Call: 1-800-227-2233 Fax: 1-888-329-8207
Internet: www.cascorp.com
Write: Cascade Corporation, PO Box 20187, Portland, OR 97294

To Order Parts . . .

Call: 1-888-227-2233 Fax: 1-888-329-0234
Internet: www.cascorp.com
Write: Cascade Corporation, 2501 Sheridan Ave., Springfield, OH 45505

5 The unit is calibrated at the factory to level. With the mast or attachment aligned at vertical (see step 1), determine the mount location. With the unit powered and the Green LED on, mark the mount location. Mix and apply a small amount of adhesive (user supplied) between the strips of mounting tape. Remove the mounting tape protective film and place the unit on the mast with the Green LED on. The unit can be recalibrated in step 6. Adhesives approved for this installation:

- Loctite 332 with Activator 7380
- Devcon S-220 two part epoxy
- Devcon Plastic Welder 14320
- JB Weld 8265-S

Apply adhesive per manufacturer's instructions.

6 To recalibrate the unit, confirm that the mast or attachment is vertical. Place and hold the magnet on the red dot located underneath the tilt indicator.

- When the magnet is over the red dot, both red LED's will illuminate.
- Other LED's may also be on at this time.

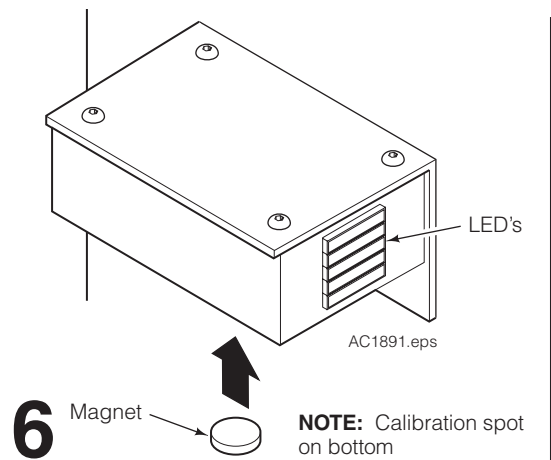
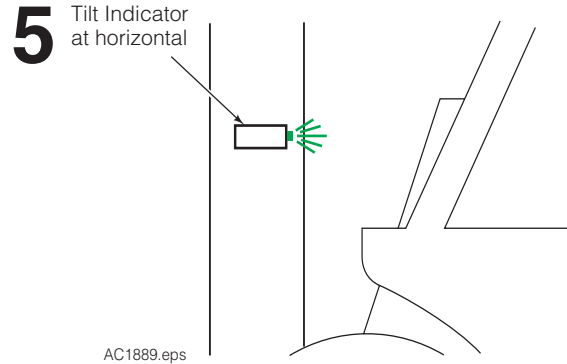
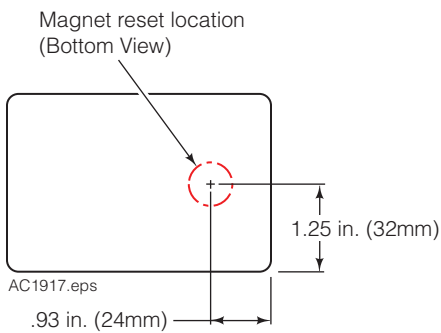

7 Power the unit. The red, green and red LED's will be ON for 1 sec. Power the unit OFF and remove the magnet. The tilt indicator will zero. If the tilt indicator is outside of it's 35 degree range, the top and bottom red LED's will flash.

8 Tilt the mast fully forward and backward to check for pinch points with the wires.

TILT INDICATOR OPERATION

The tilt direction LED's can be set in two different modes:

Mode A – Red on bottom for forward tilt

Mode B – Red on top for forward tilt





Switching Modes – Power the unit, then place and hold the magnet on the red dot located underneath the tilt indicator until red LED's come on. Wait 10 seconds until all LED's are ON for 1 sec. Remove the magnet and power cycle the unit.

Indicators manufactured before 9/15/2010 do not allow a mode change.

Operation – Mode A (Red on bottom for forward tilt)

NOTE: Test the installation prior to putting the truck in service.

To move to the vertical position, use the LED's to determine tilt position.

	Top Red – Rearward of vertical > 4°
	Top Yellow – Rearward, close to vertical, 1.5°-4°
	Green – Vertical, ±1.5°
	Bottom Yellow – Forward, close to vertical, 1.5°-4°
	Bottom Red – Forward of vertical > 4°

NOTE: Sudden acceleration or stopping will cause the indicator LED's to show red.



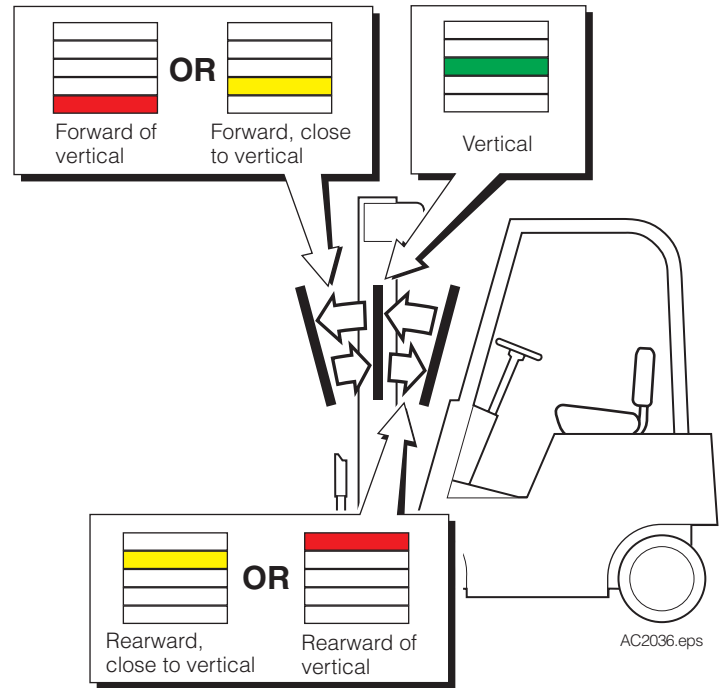

You can use a level to confirm basic operation of the unit. Yellow will change to red at 4°.



Operation – Mode B (Red on top for forward tilt)

NOTE: Test the installation prior to putting the truck in service.

To move to the vertical position, use the LED's to determine tilt position.

	Top Red – Forward of vertical > 4°
	Top Yellow – Forward, close to vertical, 1.5°-4°
	Green – Vertical, ±1.5°
	Bottom Yellow – Rearward, close to vertical, 1.5°-4°
	Bottom Red – Rearward of vertical > 4°

NOTE: Sudden acceleration or stopping will cause the indicator LED's to show red.

You can use a level to confirm basic operation of the unit. Yellow will change to red at 4°.

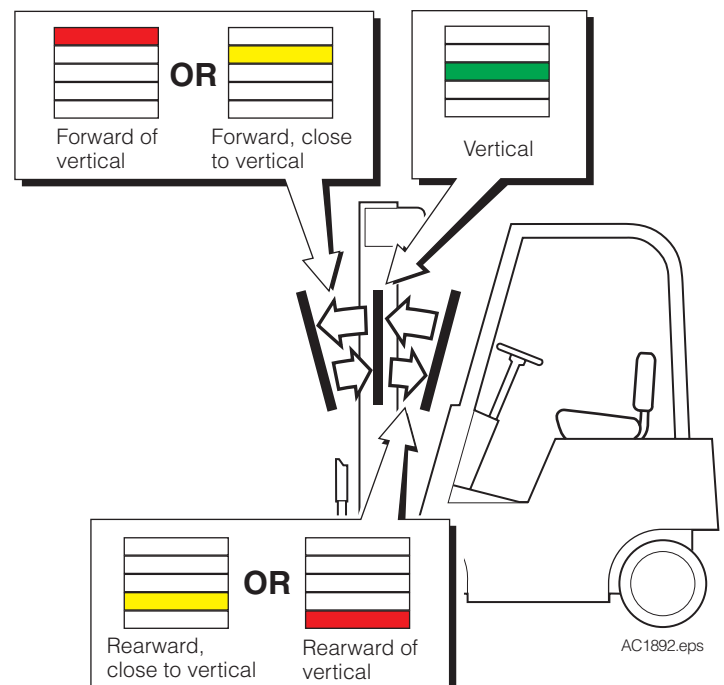

Do you have questions you need answered right now? Call your nearest Cascade Service Department. Visit us online at www.cascorp.com

AMERICAS

Cascade Corporation Parts Sales

2501 Sheridan Ave.
Springfield, OH 45505
Tel: 888-CASCADE (227-2233)
Fax: 888-329-0234

Cascade Canada Inc.

5570 Timberlea Blvd.
Mississauga, Ontario
Canada L4W-4M6
Tel: 905-629-7777
Fax: 905-629-7785

Cascade do Brasil

Rua João Guerra, 134
Macuco, Santos - SP
Brasil 11015-130
Tel: 55-13-2105-8800
Fax: 55-13-2105-8899

EUROPE-AFRICA

Cascade Italia S.R.L. European Headquarters

Via Dell'Artigianato 1
37050 Vago di Lavagno (VR)
Italy
Tel: 39-045-8989111
Fax: 39-045-8989160

Cascade (Africa) Pty. Ltd.

PO Box 625, Isando 1600
60A Steel Road
Sparton, Kempton Park
South Africa
Tel: 27-11-975-9240
Fax: 27-11-394-1147

ASIA-PACIFIC

Cascade Japan Ltd.

2-23, 2-Chome,
Kukuchi Nishimachi
Amagasaki, Hyogo
Japan, 661-0978
Tel: 81-6-6420-9771
Fax: 81-6-6420-9777

Cascade Korea

121B 9L Namdong Ind.
Complex, 691-8 Gojan-Dong
Namdong-Ku
Inchon, Korea
Tel: +82-32-821-2051
Fax: +82-32-821-2055

Cascade-Xiamen

No. 668 Yangguang Rd.
Xinyang Industrial Zone
Haicang, Xiamen City
Fujian Province
P.R. China 361026
Tel: 86-592-651-2500
Fax: 86-592-651-2571

Cascade India Material Handling Private Limited

No 34, Global Trade Centre
1/1 Rambaugh Colony
Lal Bahadur Shastri Road,
Navi Peth, Pune 411 030
(Maharashtra) India
Phone: +91 020 2432 5490
Fax: +91 020 2433 0881

Cascade Australia Pty. Ltd.

1445 Ipswich Road
Rocklea, QLD 4107
Australia
Tel: 1-800-227-223
Fax: +61 7 3373-7333

Cascade New Zealand

15 Ra Ora Drive
East Tamaki, Auckland
New Zealand
Tel: +64-9-273-9136
Fax: +64-9-273-9137

Sunstream Industries Pte. Ltd.

18 Tuas South Street 5
Singapore 637796
Tel: +65-6795-7555
Fax: +65-6863-1368

