



# Installation Instructions

## E-Series Push/Pull Gripper Hose Service Kits 206383 and 206384

This sheet shows how to replace the faceplate gripper assembly steel tubes with hose assemblies and weld a hose guard to the gripper jaw.

- 1 Fully extend the faceplate.



**WARNING:** Before removing any hoses or tubes, relieve pressure in the hydraulic system. Turn the truck off, then open the truck auxiliary valve(s) several times in both directions.

- 2 Attach an overhead hoist to the gripper assembly lifting holes. Take up slack in the chain.
- 3 Disconnect, tag and plug the hoses from the top of the junction block.
- 4 Remove the capscrews fastening the gripper assembly to the faceplate. For reassembly, tighten the capscrews to the torque values shown.
- 5 Lay the gripper assembly on the floor with the cylinders exposed.
- 6 Remove the tubes from the junction block and cylinder fittings. Remove the junction block.
- 7 Remove the pins from both ends of the cylinders. Lift away the cylinders and gripper bar.
- 8 Remove the bearings from the gripper bar.

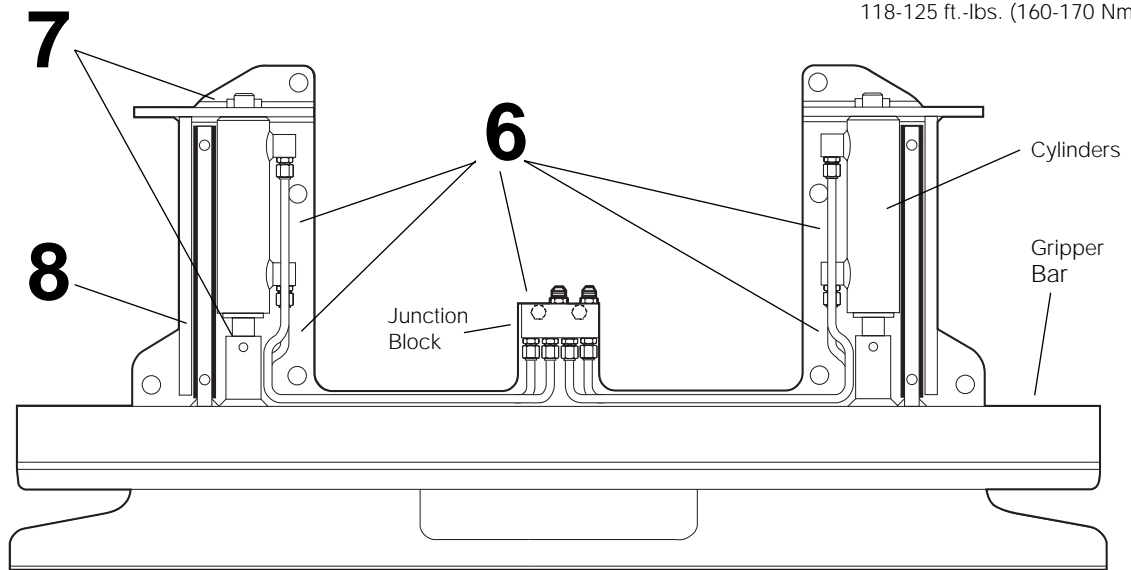
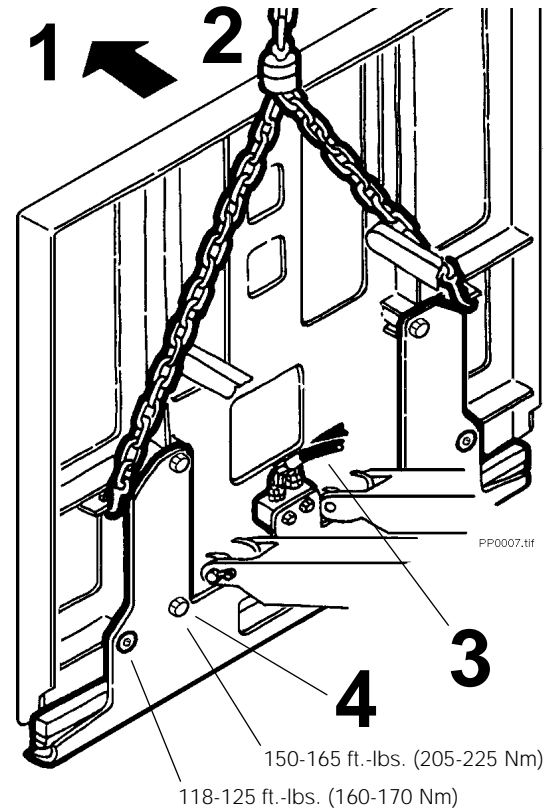

Part No. 206395 R-1

# cascade®

### For Technical Assistance . . .

Call: 1-800-CASCADE or 503-669-6300

OR

Write: Cascade Corporation, P.O. Box 20187, Portland, OR 97220

### To Order Parts . . .

Call: 513-322-1199 or FAX: 513-325-9270

OR

Write: Cascade Corporation, 2501 Sheridan Ave., Springfield, OH

- 9 Position the new hose guard on the gripper jaw using the dimensions shown. Weld the hose guard in place with E-7018 low hydrogen 1/8 in. electrodes. Clean welds and repaint.
- 10 Install the new junction block to the gripper jaw. Tighten the capscrews to a torque of 18-20 ft.-lbs. (24-26 Nm).
- 11 Install the cylinders and gripper bar using the new roll pins

and gripper bar bearings.

- 12 Install the new hoses to the junction block and cylinder fittings.
- 13 For reassembly, reverse steps 1 through 4. Run the attachment through 5 complete cycles to remove air from the hydraulic lines and check gripper sequencing.
- 14 Inspect for interferences between the hoses and gripper bar.

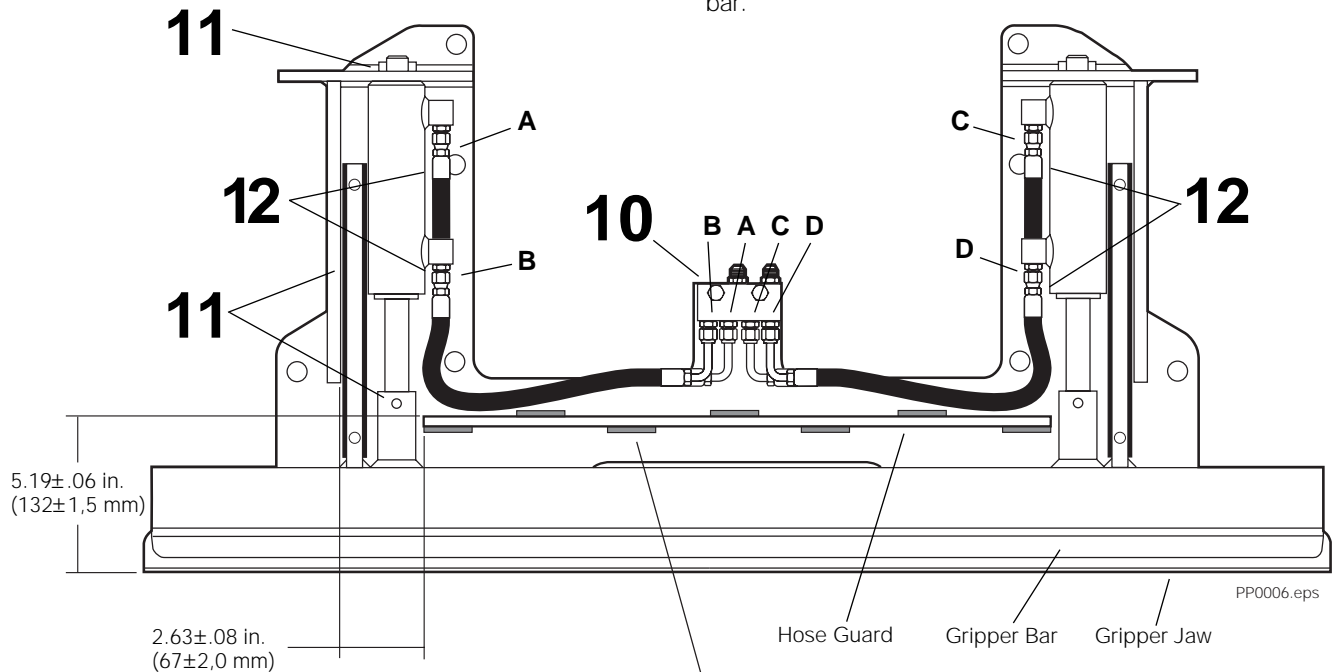

## Gripper Sequence Adjustment

The gripper bar should be adjusted to operate as follows:

**Faceplate Extend** – Gripper bar fully retracted (up) when the faceplate reaches full extension.

**Faceplate Retract** – Gripper bar down fully before the faceplate retracts.

- 1 Loosen the valve lower cartridge adjustment locknut. Operate the truck at half throttle.
- 2 Adjust the screw so the gripper bar is fully retracted when the faceplate reaches full extension. Operate the faceplate through several cycles to confirm the setting. Tighten the locknut.

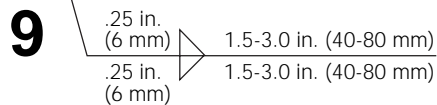

- 3 Loosen the valve top cartridge adjustment locknut. Operate the truck at half throttle.
- 4 Adjust the screw for the gripper bar to be fully lowered before the faceplate retracts. Operate the faceplate through several cycles to confirm the setting. Tighten the locknut.

