



Move heavy loads faster, excel in rugged applications.

*Designed
with great
visibility, easier
maintenance,
and superior
durability.*

APPLICATIONS

Designed to handle heavy loads such as bricks, construction products and fertilizer. This durable unit is perfect for outdoor applications due to the sealed inner fork bearing design. Cascade's Single-Double Pallet Handler allows single pallet handling without protrusion outside the truck profile. Spreading the forks hydraulically allows handling of two pallets side by side. Sideshifting provides added flexibility for aligning forks or pallets in tight areas.

FEATURES

- Superior visibility through and over the frame for damage free handling at all stacking heights
- All steel frame for increased overall durability, eliminating flexing
- Easy access cylinders for quick servicing
- Bolt-on Interchangeable forks for low service cost
- Full-length, fully enclosed wrap around UHMW plastic bearings provide maximum strength and full bearing support, greatly reducing wear on bearing surface
- Inner forks mounted on a chrome pin for greater inner fork stability

OPTIONS

- Various load backrest configuration heights, fork lengths and sections
- Various fork set spreads and opening ranges
- Quick-disconnect lower hooks
- Drop shank forks—forks are lowered relative to the attachment frame
- Non-Sideshifting models available



SINGLE-DOUBLE HIGH CAPACITY

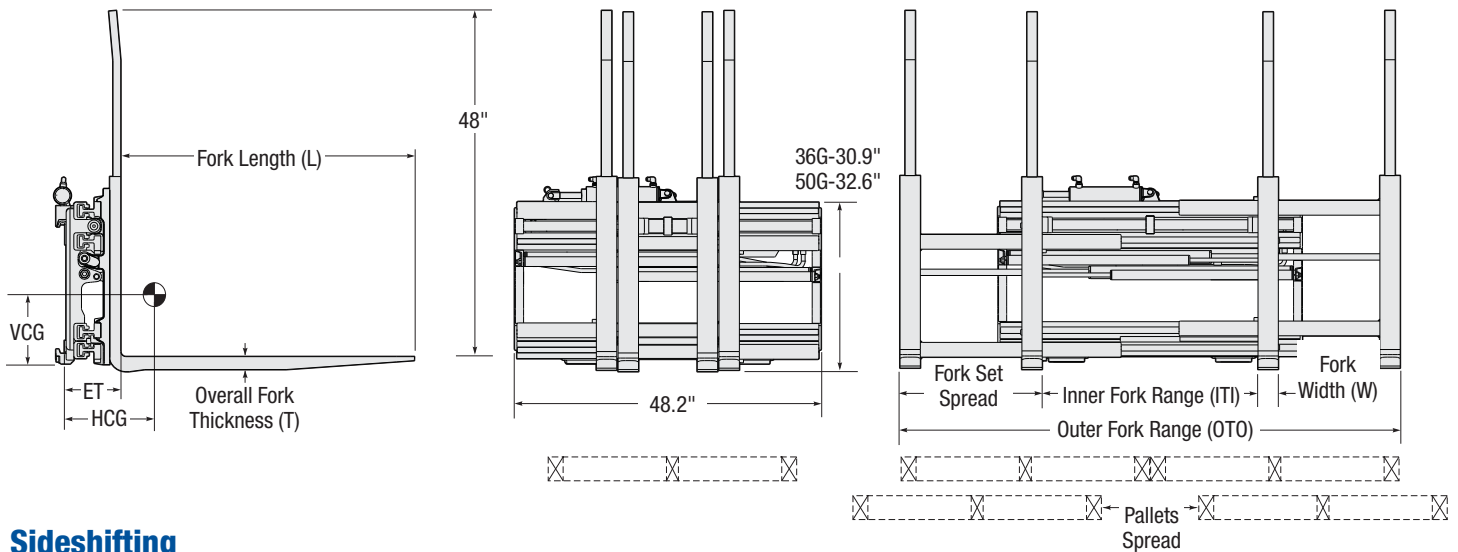

Sideshifting

Catalog Order No.	Capacity @ 24" (600 mm) Load Center		Mfg. Class	Min. Truck Carriage Width	Weight		Effective Thickness ET	Horizontal Ctr. Of Gravity HCG	Vertical Ctr. of Gravity VCG	Inner Fork Range ITI	Outer Fork Range OTO	Avg. Pallet Spread	Fork Set Spread	Fork Size L x W x T
	lbs	kg			lbs	kg								
36" x 36" Beverage Pallets														
36G-FDS-B005	8,000	3,600	III	.6"	1,550	700	10.2"	8.2"	12.5"	13.0"-32.1"	26.0"-80.1"	20.0"	24.0"	36.0" x 3.2" x 2.4"
50G-FDS-C005	10,000	5,000	IV	38.6"	1,575	715	10.2"	8.0"	11.2"	13.0"-32.1"	26.0"-80.1"	20.0"	24.0"	36.0" x 3.2" x 2.4"
48" x 40" Block and GMA Pallets ①														
36G-FDS-B221	8,000	3,600	III	38.6"	1,635	740	10.2"	9.1"	12.1"	14.6"-28.7"	27.6"-82.7"	15.0"	27.0"	42.0" x 3.2" x 2.4"
50G-FDS-C221	10,000	5,000	IV	38.6"	1,655	750	10.2"	9.0"	10.4"	14.6"-28.7"	27.6"-82.7"	15.0"	27.0"	42.0" x 3.2" x 2.4"
44" x 56" Container Pallets														
36G-FDS-B013	8,000	3,600	III	38.6"	1,700	775	10.2"	11.6"	11.4"	13.0"-28.1"	26.0"-80.1"	11.0"	26.0"	54.0" x 3.2" x 2.4"
50G-FDS-C013	10,000	5,000	IV	38.6"	1,725	785	10.2"	11.5"	10.0"	13.0"-28.1"	26.0"-80.1"	11.0"	26.0"	54.0" x 3.2" x 2.4"

① This model can handle GMA type stringer and block pallets, including Chop Type III and Mark 55 pallets in both directions. The single-mode fork positioning range is 15.0" to 21.0" in-to-in, or 27.5" to 33.5" out-to-out. Average pallet spread is 8.0" for both pallets. No additional truck auxiliary valves required, beyond the normal two auxiliary valves.

- ▶ Other fork lengths available.
- ▶ FDS unit limited to 60" fork length maximum. For longer forks see FQS units on page 3-5.
- ▶ Right hand termination standard, left hand termination available at no charge.
- ▶ Plastic pallets may require modified fork dimensions. For other ranges or fork dimensions please consult Cascade.
- ▶ The outer fork tines are .2" higher than the inner fork tines.
- ▶ 8" (200 mm) total sideshift.

HYDRAULIC FLOW AND PRESSURE

Maximum Pressure psi/bar	Min-Rec-Max Function 1 gpm	Min-Rec-Max Function 2 gpm
2,900/200	1 - 2 - 3	4 - 7 - 7

HYDRAULIC FUNCTIONS

Hydraulic Functions	Truck Auxiliary Valves Required
2	2